



TR12 AREA/SCENE LIGHTING



- Included with Lights:
- > Installation Screws
 - > Base Gasket
 - > 10" Wire

The TR12 Series Surface Mount LED Lights are ideally suited for illuminated work areas around Construction/Emergency/Utility and Municipal Trucks as well as Command/Office Vehicles and Trailers. The compact design of the TR12 Lights make them ideal for installing over doors or in tool compartments as well.

TR12 Series Specification

- 5 Year Warranty on the LED Light Module
- 12 High Intensity LEDs
- 1700 Lumen Raw Lumen
- 10-36VDC Multi-Voltage Input
- Average Consumption: 0.67A@12VDC / 0.34A@24VDC
- Corrosion, Vibration, Moisture resistance
- IP67 Rated to Resist Water, Dust, Dirt and Sand Found in Harsh Environments
- 40° Degree Downward Angle
- Working Temperature: -30°C to +70°C
- 5 Color Plastic Housing Selection

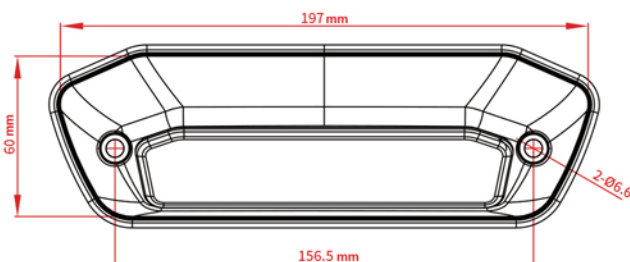
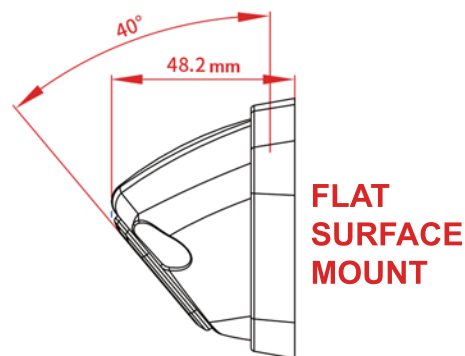

TR12PY9009CC CHROME OPTIONAL	TR12PY9009CW WHITE STANDARD	TR12PY9009CB BLACK STANDARD	TR12PY9009CR RED OPTIONAL	TR12PY9009CY YELLOW OPTIONAL

FOR MORE INFORMATION, CONTACT:

D&R ELECTRONICS CO. LTD.

8820 GEORGE BOLTON PARKWAY

BOLTON, ONTARIO, CANADA, L7E 2Y4

T: (905) 951-9997 | FAX: 905-951-0019

www.dandrelectronics.com

