

Automotive Power Distribution Unit User Manual

Model:
PDU-6SS



Table of Contents

Product Overview.....	2
Introduction/Features/Technical Specifications.....	3
Warnings.....	4
Installation.....	5
Wiring Diagram.....	6
Wire Gauge Size Tables.....	7
Modes of Operation.....	8
Programming Low Voltage Shutdown and Timed Shutdown.....	9
Package Contents.....	10
Warranty and Product Return Policy.....	12

Product Overview

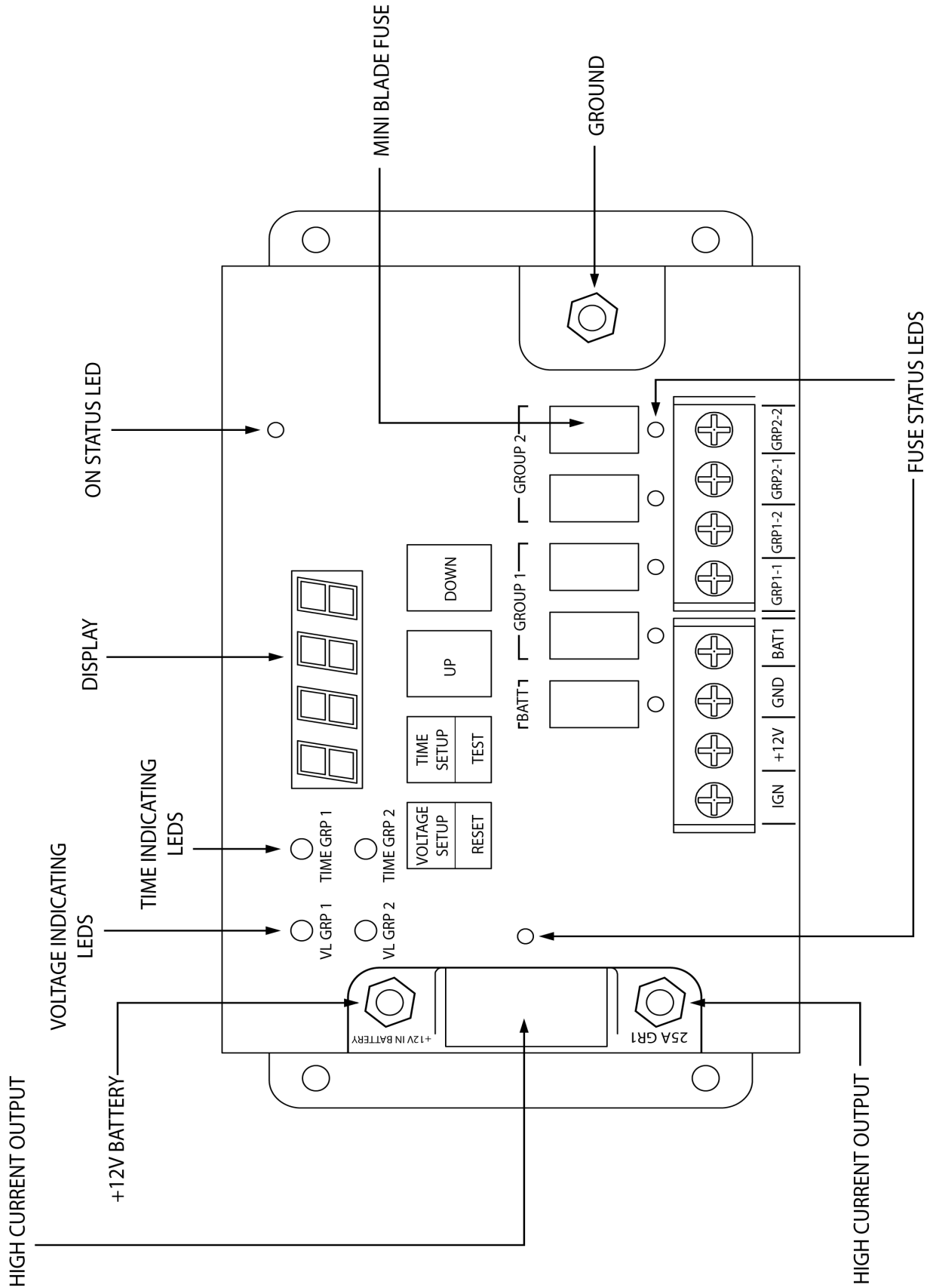

Figure 1: PDU-6SS

Introduction

The PDU-6SS is designed to provide automotive emergency and public service vehicle equipment installers with a solid state, single point power distribution system for installed electrical devices. The installation is fast, reliable and safe. It offers programmable low battery voltage shutdown, programmable timed shutdown, power distribution and equipment protection. The PDU-16SS provides a direct, easily traceable route to the input power source avoiding interfering with the vehicles factory wiring harnesses. All circuits are individually fused (MAXI fuse for the heavy duty outputs & MINI fuses for the standard outputs) and each output has a FUSE OK LED indicator for ease of troubleshooting.

Features

- Programmable Low Battery Voltage Shutdown (11V to 13V)
- Programmable Timed Shutdown (2 minutes TO 30 hours)
- Vehicle Battery Voltage Monitoring
- Each output has an LED fuse status indicator
- ZERO Current consumption in Standby Mode
- Timed Shutdown Mode
- Test Mode (all outputs ON for 20 seconds)
- Reset Mode (resets all outputs to zero)
- 6 Outputs (1 battery and 5 timed)

Technical Specifications

Voltage Range: 11-18 VDC

Maximum Current Load: 15A per output, fused at 20A
25A per heavy duty output, fused at 40A
80A total maximum current per PDU

Stand-by Current: 0A

Programmable Low Voltage Disconnect: Programmable from 11VDC
Factory default set at 11.5VDC (10 second delay)

NOTE: *Battery manufacturers recommend to not program low voltage disconnect below 11 VDC unless the vehicle is equipped with a second battery.*

High Voltage disconnect set at 18VDC, (10 second delay)

Programmable timer setup: 1 minute - 99.59 hours. Factory Default 1 minute

Fuse Type: MINI fuse for regular outputs
MAXI fuse for heavy-duty outputs

Operating Temperature: -40° C to +65° C (-40F to +149F)

Dimensions: L 6.2" X W 4.5" X H 1.5"

Weight: 1.15 Lbs

Warning

1. The use of emergency warning devices does not ensure the safety of the operator. The operator is responsible to ensure safe operation of the vehicle regardless of whether the warning device is in operation or not
2. The effectiveness of this or any warning device is highly dependent on proper installation and maintenance. **Read the manufactures instructions before installing and follow all recommendations.**
3. When in use the operator must ensure that the warning signal is visible and not obstructed by vehicle components (i.e. open trunk lid), people or other obstructions
4. This device is intended for use by authorized personnel only. It is the responsibility of the user to ensure that all local, state, provincial and federal laws are being complied with. D&R assumes no liability for any loss resulting from the use of this device.
5. The device must be installed so as not to reduce the output performance of vehicle systems.
6. Placement of control switches must be so as to provide convenient reach for the operator without losing eye contact with the road.
7. Emergency warning devices require high electrical voltages and/or currents. Properly connect and ground all circuits. Shorting or improper grounding of this device may caused personal injuring, vehicle damage and/or device damage.
8. All operators should be properly trained in the operation of this device to ensure both operator and public safety
9. Any device used inside a vehicle, may cause severe personal injury if not properly mounted and secured. Objects used in the vehicle may become airborne during a collision or other sudden changes in vehicle speed or direction, such as braking, acceleration or turns.
10. Be sure to mount unit through the steel of the vehicle. Avoid mounting through plastic or other non-structural materials.
11. **POINT OF INSTALLATION MUST NOT INTERFERE WITH DEPLOYMENT OF VEHICLE AIR BAGS.**
12. D&R Electronics recommends that this and any of our other products be installed by qualified personnel.
13. Good wiring practices and thorough knowledge of vehicle power systems is required by the installer of this and any other product.
14. Looms, grommets, cable ties or other installation hardware should be used to anchor and protect wiring.
15. All wire sizes must meet the minimum sizes specified by the manufacturer.
16. Splices should be minimized and made in a fashion so as to protect from moisture which could cause corrosion thereby reducing conductivity.
17. The exact number of available connections varies by application. Refer to the specifications and typical output fusing combinations to ensure that the safety and reliability of this product is not compromised.

Maintenance

The PDU-16SS does not require user maintenance except for the individual fuse replacements.

Warning



Do not attempt to open or repair.

Contact your local distributor or D&R Electronics for repair.

Mechanical Installation

NOTE the PDU is not weather tight. Do not mount it in the engine compartment, on the exterior of the vehicle or an area where there is moisture, dirt or other contaminants. Ensure that the mounting location is flat and the device is secured to solid vehicle body parts.

1. Determine an appropriate mounting location.
2. Confirm there is adequate access and clearance for the wiring and all connections.
3. Secure the PDU with 4 self-tapping mounting screws (not supplied).

Electrical Installation

12V Battery

Using appropriate size wire connect to the positive battery terminal fuse at the battery side with a 100A fuse or circuit breaker.

Ground

Using appropriate size wire connect to the negative battery terminal or a suitable chassis ground.

Ignition Sense

Connect this terminal to the vehicle ignition switch using 18 gauge wire.

Battery Sense

Connect this terminal directly to the positive of the battery using a 18 gauge wire fused with a 5A fuse. *This connection must be made in order for the PDU-6SS to work.*

Ground Sense

Connect this terminal to the negative side of the battery or a suitable chassis ground. *This connection must be made in order for the PDU 6SS to work.*

Outputs

The PDU offers the following outputs. (1) 25A in group 1, (2) 15A in group 1, (2) 15A in group 2 and (1) directly from the battery (this output is available even when the PDU is dormant).

NOTE: When the IGNITION is OFF and the main +12V power input is disconnected, the DISPLAY will stay ON until both timers expire or the BATTERY SENSE input is disconnected.

Wiring Diagram

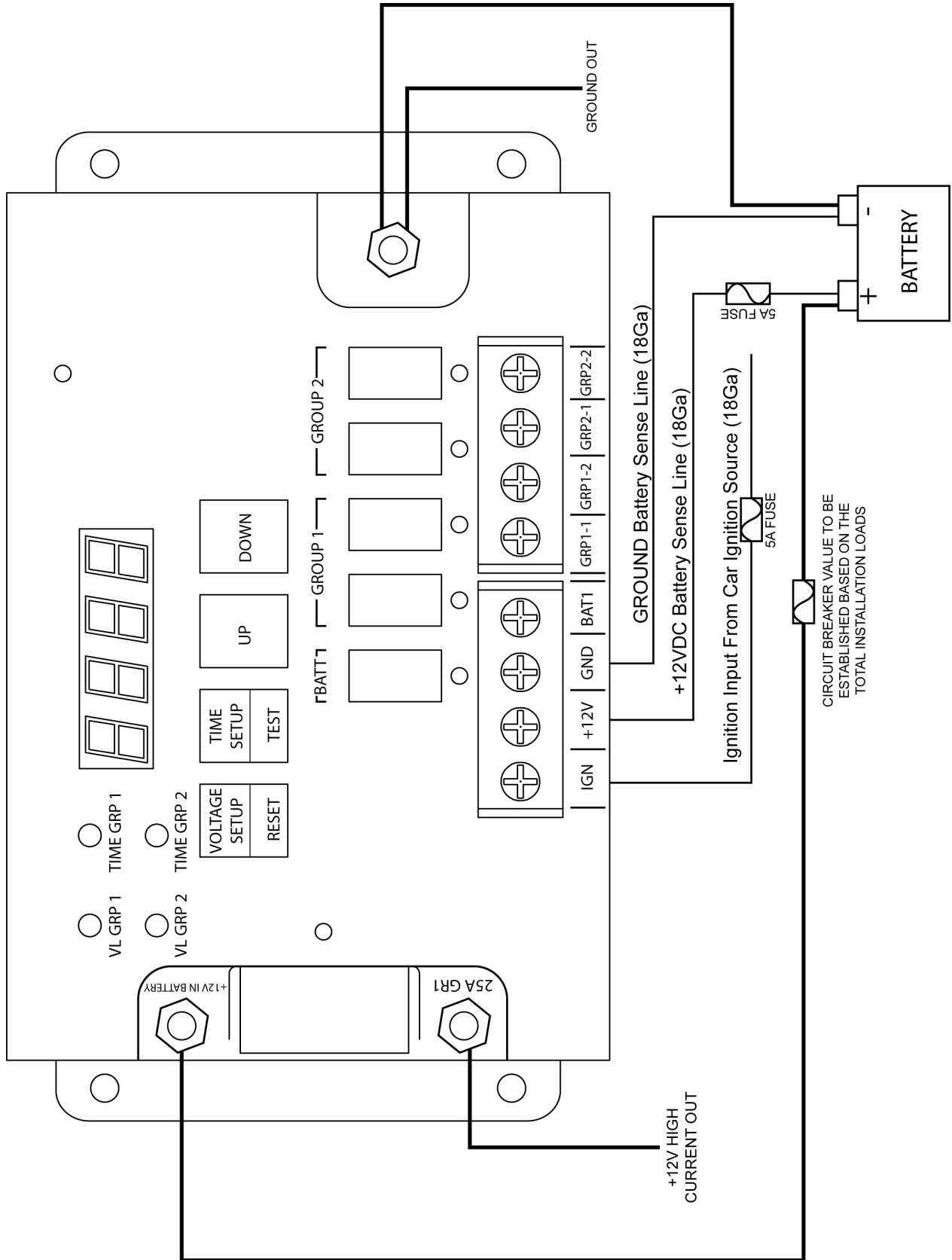

Figure 2: Wiring

Table 1: Recommended Input Power Feed Wire Size

Max. Total Load Current Amps	Wire Size (AWG) vs Wire Length (3% drop)				
	<5 ft.	5-10 ft.	10-15 ft.	15-20 ft.	25-30 ft.
25	#10	#6	#6	#4	#2
50	#6	#4	#2	#2	#0
75	#6	#2	#1	#0	#3/0
100	#4	#2	#0	#2/0	#4/0

Table 2: Recommended Circuit Load Wire Size

Max. Total Load Current Amps	Wire Size (AWG) vs Wire Length (3% drop)				
	1-5 ft.	5-10 ft.	10-15 ft.	15-20 ft.	25-30 ft.
5	18	18	18	16	14
10	18	16	14	14	12
15	18	14	12	12	10
20	16	14	12	10	8

Modes of Operation

Standby Mode

In Standby Mode the PDU is dormant with zero consumption. It awakes either by turning the Ignition ON or by depressing the test switch. The test switch will turn on all outputs for two minutes and if no other action is taken during this time, the PDU will go dormant again.

Low Battery Voltage Shutdown Mode

The PDU provides a battery protection by turning off the outputs when the voltage reaches a pre-set value. This setting is the same for both groups.

Timed Shutdown Mode

The PDU allows the user to set the time remaining after the ignition switch is turned off. This setting is the same for both groups. The 7 segment display will cycle through and indicate the time remaining for each output group.

Test Mode

Pressing the TIME SETUP/TEST button for at least 2 seconds will start a 20 second test mode for both output groups.

Reset Mode

Pressing the VOLTAGE SETUP/RESET button for at least 2 seconds will reset the PDU to STANDBY mode.

Vehicle Battery Voltage Monitoring

The vehicle battery voltage is continuously monitored.

Programming the PDU-6SS

NOTE: If no action is taken within 20 seconds during setup, the PDU will return to Standby Mode.

Low Voltage Shutdown Setup

The PDU-16SS' factory default LOW VOLTAGE SHUTDOWN value is set to 11.5 VDC for both Group 1 and Group 2 outputs. This value can be adjusted by the user for each of the two output groups separately by following these steps:

- Tap the VOLTAGE SETUP/RESET button. The VL GRP1 LED will turn ON and the display will show the current voltage set for GROUP 1 outputs. Tap the UP or DOWN buttons to enter the new voltage.
- Tap the VOLTAGE SETUP/RESET button. The VL GRP2 LED will turn ON and the display will show the current voltage set for GROUP 2 outputs. Tap the UP or DOWN buttons to enter the new voltage.
- Tap the VOLTAGE SETUP/RESET button again to save the new values.

Note: - *When the vehicle battery voltage drops below the pre-set voltage the outputs will turn off. This is the same for both groups.*

- The minimum shutdown voltage cannot be set below 11.5VDC unless the vehicle is being fitted with a second battery.

Timed Shutdown Setup

The PDU-6SS factory default shutdown times are set to:

- 2 minutes for GROUP 1 outputs
- 2 hours for GROUP 2 outputs

This value can be adjusted by the user by following these steps:

- Tap the TIME SETUP/TEST button. The TIME GRP1 LED will turn ON and the display will show the current shutdown time set for GROUP 1 outputs. Tap the UP or DOWN buttons to enter the new time.
- Tap the TIME SETUP/TEST button. The TIME GRP2 LED will turn ON and the display will show the current shutdown time set for GROUP 2 outputs. Tap the UP or DOWN buttons to enter the new time.
- Tap the TIMER SETUP/TEST button again to save the new values.

Note:

When the vehicle IGNITION switch is turned on, the countdown will be stopped.

Package Contents

QTY	Part Number	Description
1	PDU-6SS	PDU-16SS unit w/ 16 out, display, dual programmable timer and voltage
1	212-0024-6SS	Manual PDU-6SS unit
1		Designator sheet for PDU-6SS to record all setup installation data
4	196-0070	Lug LD 6 AWG stud 1/4"
16	205-0052	Spade #8 16-14 Ga

NOTE; MINI and MAXI fuses are available for purchase.

NOTES

WARRANTY

D & R Electronics warrants its new products to be free from defects in material and workmanship, under normal use and service for a period of one year on parts replacement.

This warranty applies only to original purchasers acquiring the product directly from D&R Electronics, or its authorized dealers. Warranty will not be recognized without proof of purchase or bill of sale.

This warranty is not transferable.

The warranty begins on the date of delivery to the first user/purchaser.

This warranty shall not apply to products which must be repaired due to normal wear and tear, negligence, improper installation, abuse, misuse, or which have been altered or modified at a facility other than D & R Electronics, or its authorized depot centers.

Units proved to be defective within the warranty period, based on an examination by D&R Electronics, will be replaced or repaired at D & R Electronics' option. This warranty does not cover travel expenses or labor charges for removal or installation.

Lamps, flash tubes, batteries or other items considered consumables are not covered under warranty.

This warranty is in lieu of all other express warranties. D&R Electronics makes no warranties, expressed or implied, other than the express warranties contained herein.

PRODUCT RETURN POLICY

In order to provide you with faster service, product returns for repair or replacement, must have a **Return Goods Authorization Number (RGA number)**. Please contact our company to obtain a RGA number before you return the product to D & R ELECTRONICS. Write the RGA number clearly on the package. Be sure you use sufficient packing materials to avoid damage to the product being returned while in transit.

D & R ELECTRONICS assumes no responsibility or liability for expenses incurred for the removal and/or the installation of products requiring service and/or repair. Repairing or replacing product is at the discretion of D & R ELECTRONICS.

D&R ELECTRONICS Co. LTD.

CANADA

8820 George Bolton Pkwy.

Bolton, Ontario L7E 2Y4

Tel: (905) 951-9997

Fax: (905) 951-0019

USA

2299 Kenmore Avenue

Building 3, Doors 11-14

Buffalo, New York 14207

Toll Free: 1-800-538-7338

www.dandrelectronics.com