

**2020 Utility Floor Plate**  
(905-0148A)  
Installation Manual

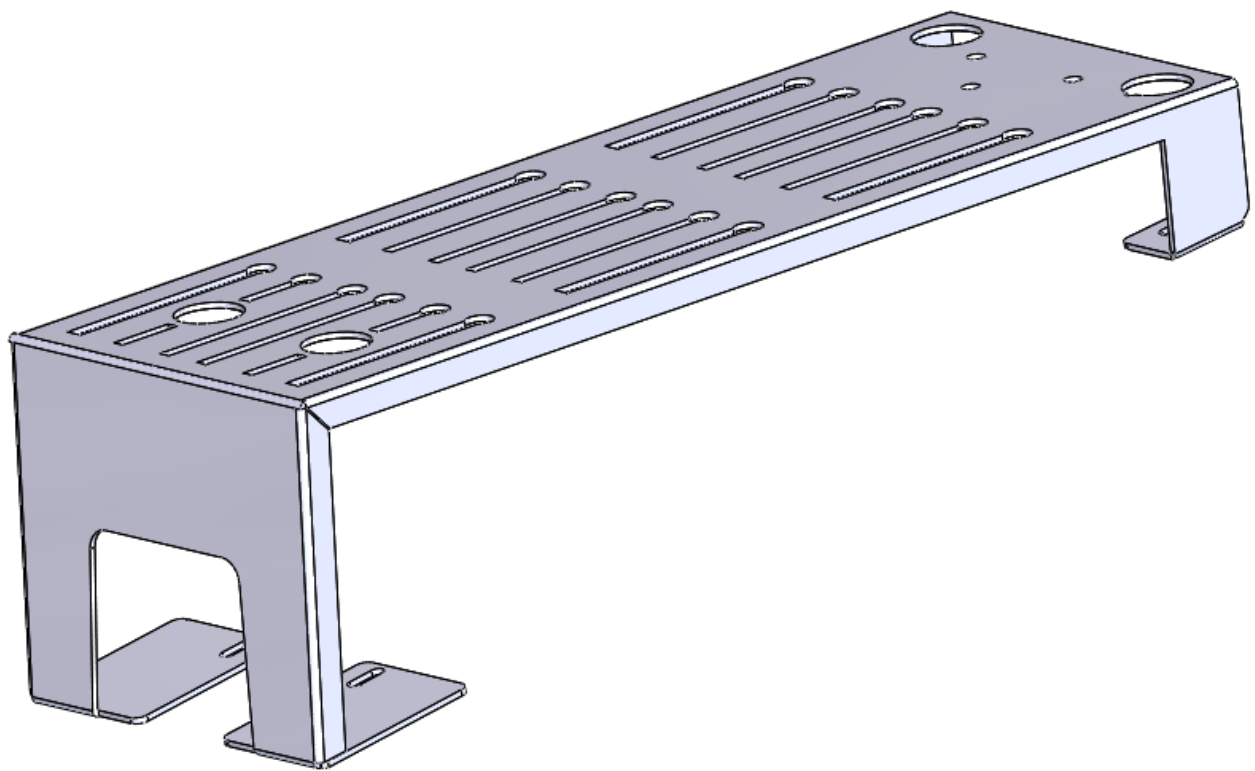

<b>Content</b>	<b>Page</b>
Installation Instructions	2
Warranty and Return Policy	3

## Installation Instructions:

### Step 1:

Remove the Factory Floor Plate by removing the 2 bolts located under the dash, 2 inside the cutouts on top of the plate and bolts on the back side of the plate. Retain the hardware for new floor plate.

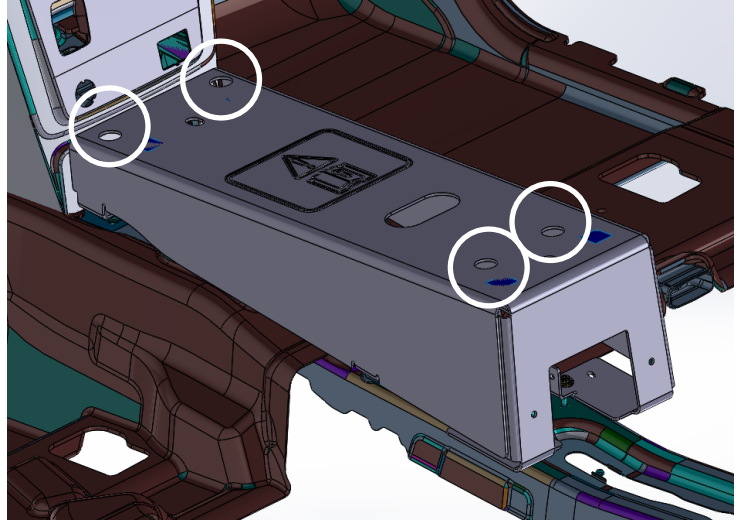

### Step 2:

**Carefully** place new Floor Plate where the factory one was. The four slots located on the feet of the new floor plate will line up with the factory studs. Push the floor plate tight to the dash and secure with the hardware removed in Step 1.

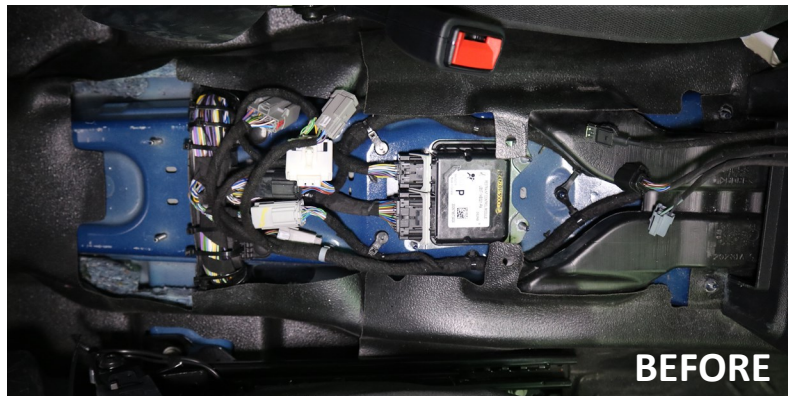

Installation is now complete.

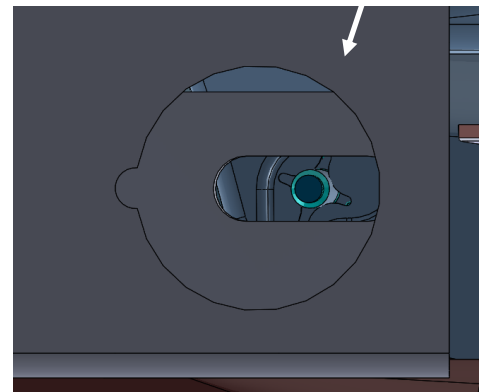
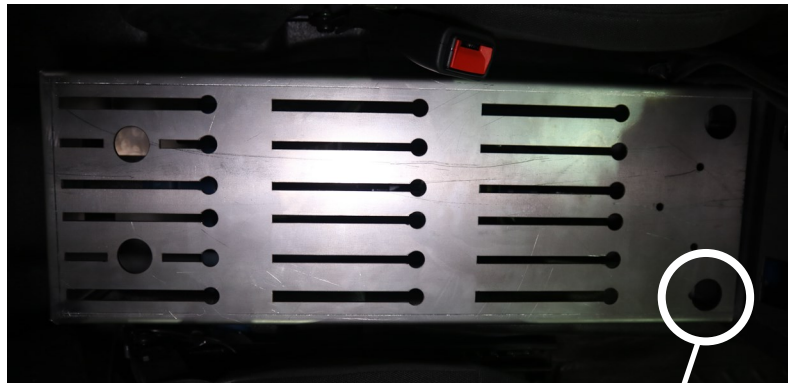

## WARRANTY

D & R Electronics warrants its new products to be free from defects in material and workmanship, under normal use and service, for a period of one year on parts replacement, and one year on labor.

This warranty applies only to original purchasers acquiring the product directly from D&R Electronics, or its authorized dealers. Warranty will not be recognized without proof of purchase or bill of sale. This warranty is not transferable.

The warranty begins on the date of delivery to the first user/purchaser. This warranty shall not apply to products which must be repaired due to normal wear and tear, negligence, improper installation, abuse, misuse, or which have been

altered or modified at a facility other than D & R Electronics, or its authorized depot center. Units proved to be defective within the warranty period, based on an examination by D&R Electronics, will be replaced or repaired at D & R Electronics' option. This warranty does not cover travel expenses or labor charges for removal or installation. Lamps, flash tubes, batteries or other items considered consumables are not covered under warranty.

This warranty is in lieu of all other express warranties. D&R Electronics makes no other warran-

## PRODUCT RETURN POLICY

In order to provide you with faster service, product returns for repair or replacement, must have a **Return Goods Authorization Number (RGA number)**. Please contact our company to obtain a RGA number before you return the product to D & R ELECTRONICS. Write the RGA number clearly on the package. Be sure you use sufficient packing materials to avoid damage to the product being returned while in transit.

D & R ELECTRONICS assumes no responsibility or liability for expenses incurred for the removal and/or the installation of products requiring service and/or repair. Repairing or replacing product is at the

### D&R ELECTRONICS Co. LTD.

#### CANADA

8820 George Bolton Pkwy.  
Bolton, Ontario L7E 2Y4

Tel.: (905)951-9997  
Fax: (905)951-0019

#### USA

2299 Kenmore Ave  
Building #3, Doors 11-14  
Buffalo, NY, 14207

Toll Free 1-800-538-7338

[www.dandrelectronics.com](http://www.dandrelectronics.com)