

2021 Grand Caravan LT6600 Floor Mount Base 906-0989A

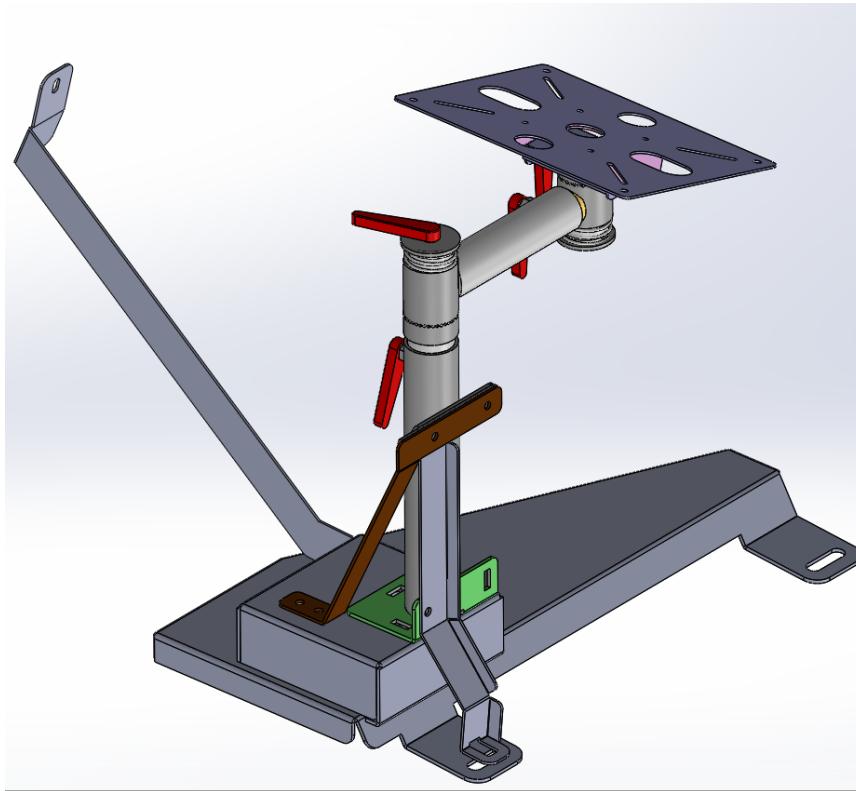

Content	Page
Assembly Overview	2
Installation Instructions	3-9

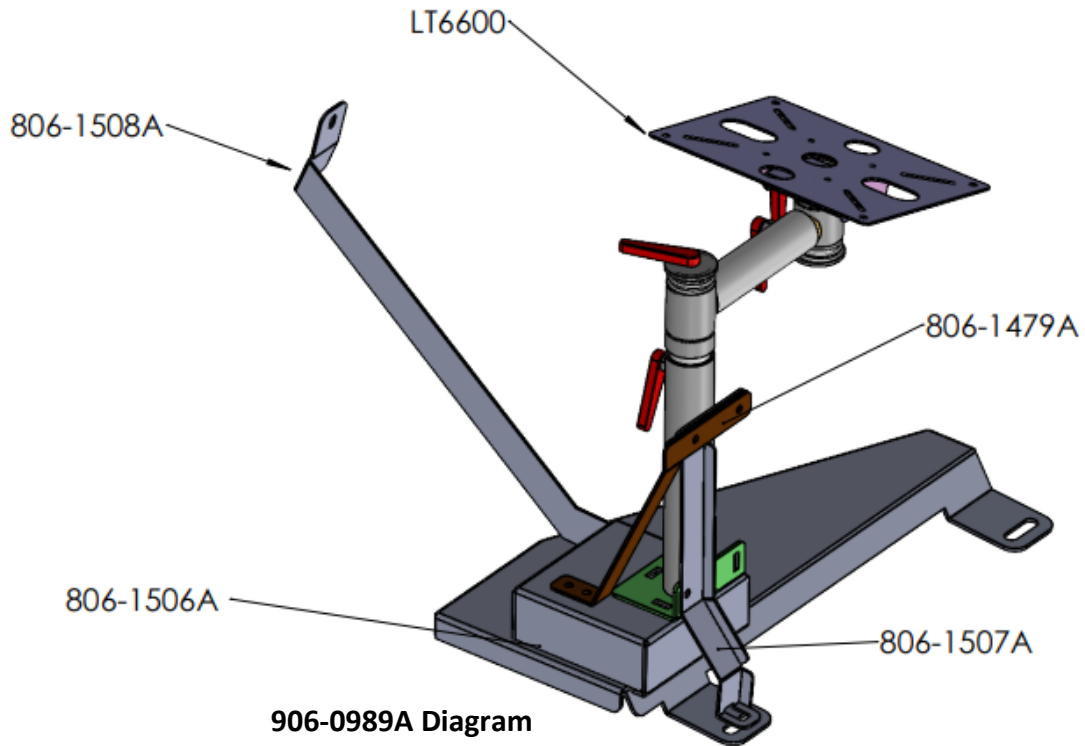

TABLE 1) HARDWARE

	Description	Part No.	Qty
1	1/4 -20 x 5/8 Carriage Bolt	401-0032	3
2	1/4 -20 x 3/4 Hex Bolt	401-0023	7
3	1/4 -20 Lock Washer	403-0004	11
4	1/4 -20 Hex Nut	402-0005	3
5	1/4 -20 Flat Washer	403-005A	6

TABLE 2) TOOLS

	Description
1	Ten (10) Millimeter Wrench
2	Ten (10) Millimeter Socket Wrench
3	Fifteen (15) Millimeter Wrench
4	Fifteen (15) Millimeter Socket Wrench
5	Size Twenty-Five (25) Torx Wrench



1) LT6600 Grand Caravan Mount base is installed under the front passenger side seat. Remove two (2) plastic bolt covers to reveal fifteen (15) millimeter bolt fastening the front of the seat down to the vehicle.



2) Remove passenger side plastic feet covers fastened by four (4) Torx head screws.



3) Completely remove the front two 15 millimeter bolts using a socket wrench.



4) The two rear bolt locations for the front passenger side seat are located under rear stow away seat storage trap door.



5) Use a 15 millimeter wrench to loosen but do not completely remove the two rear seat bolts.



6) Once the front bolts are removed and the rear bolts are loosened, the front of the passenger side seat can be lifted.



7) Place 806-1506A LT6600 Grand Caravan Base over seat bolt hole locations as seen above.



7) Place the seat down over the 806-1506A LT6600 Grand Caravan base .



8) Install the front right 15 millimeter bolt hand-tight, leaving the ability to adjust the position of the 806-1506A LT6600 Grand Caravan base.



9) Place LT6600 over the 806-1506A LT6600 Grand Caravan Base.



10) Install three (3) (hand-tight) 1/4 -20 3/4 Hex Bolts with three (3) 1/4 20 lock washers and three (3) 1/4-20 flat washer (one per bolt).



11) Continued from step ten (10), do not fasten the bolts down tightly at this stage. This will allow for small movement while adjusting.



12) Place 806-1507A strap1 as seen with the flanges facing the rear of the vehicle and a lining the 806-1507A strap1 holes with LT6600 holes.



13) Place 806-1479A LT Strap1 as seen in the photo above. Align the holes on 806-1507A strap1 & 806-1506A LT6600 Grand Caravan Base.



14) Install three (3) (hand tight) 1/4 –20 5/8 Carriage Bolts with three (3) 1/4-20 lock washers (one per bolt) and three (3) 1/4-20 Hex Nuts. Fastening the two straps to the LT6600 mount.



15) Continued from step fourteen (14).



16) Use two (2) 1/4-20 x 3/4 Hex bolts to fasten (hand tight) 806-1479A LT Strap1 to 806-1506A LT6600 Grand Caravan Base.

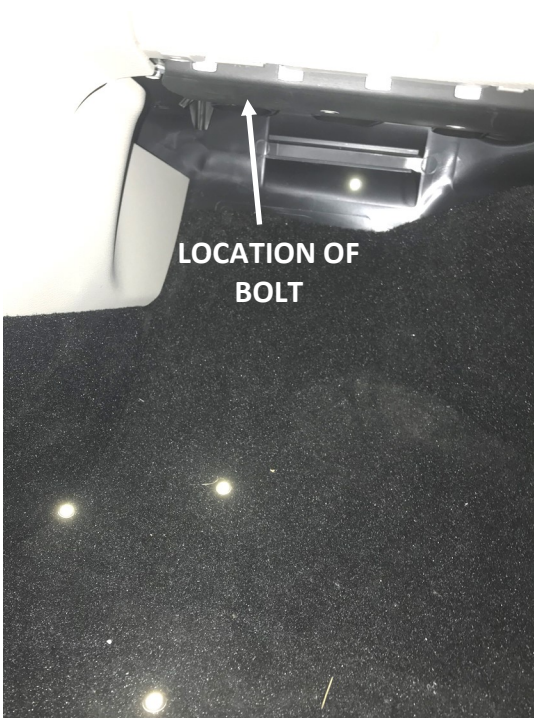

17) Photo location front PS forward facing under glove box.

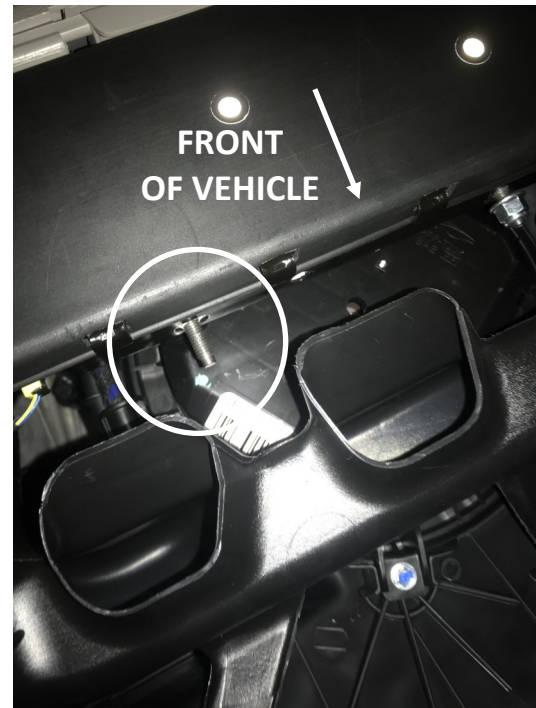

18) Locate the left most OEM bolt up behind the back of the glove box. Seen above with out a hex flange nut. (The hex flange nut will be installed on the OEM bolt before installation of 906-0989A Grand Caravan.)



19) Use a ten (10) millimeter wrench to remove the OEM hex flange nut found under glove box.



20) Place 806-1508A strap2 over the left most OEM bolt seen in step 18.



21) Place the OEM hex flange nut on to the left most bolt just enough for the threads to bite, giving 806-1508A strap2 lots of play to move.



22) Use two (2) 1/4-20 x 3/4 Hex Bolt s with two (2) 1/4-20 lock washers to hand tight fasten 806-1508A strap2 to 806-1506A LT6600 Grand Caravan Base. A socket wrench may be needed to push the 806-1508A strap2 into place.



23) Install Front left fifteen (15) millimeter bolt fastening down 806-1507A strap1 & 806-1506A LT6600 Grand Caravan to the vehicle floor.



24) Fasten down all 17 bolts including the four Torx in the seat plastic foot covers and the two (2) fifteen (15) millimeter rear seat bolts.



WARRANTY

D & R Electronics warrants its new products to be free from defects in material and workmanship, under normal use and service, for a period of one year on parts replacement, and one year on labor.

This warranty applies only to original purchasers acquiring the product directly from D&R Electronics, or its authorized dealers. Warranty will not be recognized without proof of purchase or bill of sale. This warranty is not transferable.

The warranty begins on the date of delivery to the first user/purchaser. This warranty shall not apply to products which must be repaired due to normal wear and tear, negligence, improper installation, abuse, misuse, or which have been

altered or modified at a facility other than D & R Electronics, or its authorized depot center. Units proved to be defective within the warranty period, based on an examination by D&R Electronics, will be replaced or repaired at D & R Electronics' option. This warranty does not cover travel expenses or labor charges for removal or installation. Lamps, flash tubes, batteries or other items considered consumables are not covered under warranty.

This warranty is in lieu of all other express warranties. D&R Electronics makes no other warranties, expressed or implied, than the express warranties contained herein.

PRODUCT RETURN POLICY

In order to provide you with faster service, product returns for repair or replacement, must have a

Return Goods Authorization Number (RGA number). Please contact our company to obtain a RGA number before you return the product to D & R ELECTRONICS. Write the RGA number clearly on the package. Be sure you use sufficient packing materials to avoid damage to the product being returned while in transit.

D & R ELECTRONICS assumes no responsibility or liability for expenses incurred for the removal and/or the installation of products requiring service and/or repair. Repairing or replacing product is

D&R ELECTRONICS Co. LTD.

CANADA

8820 George Bolton Pkwy.
Bolton, Ontario L7E 2Y4

Tel.: (905)951-9997

Fax: (905)951-001

USA

2299 Kenmore Ave
Building #3, Doors 11-14
Buffalo, NY, 14207

Toll Free 1-800-538-7338

www.dandrelectronics.com