

REV.	DESCRIPTION	DCR	BY	DATE	APPROVED

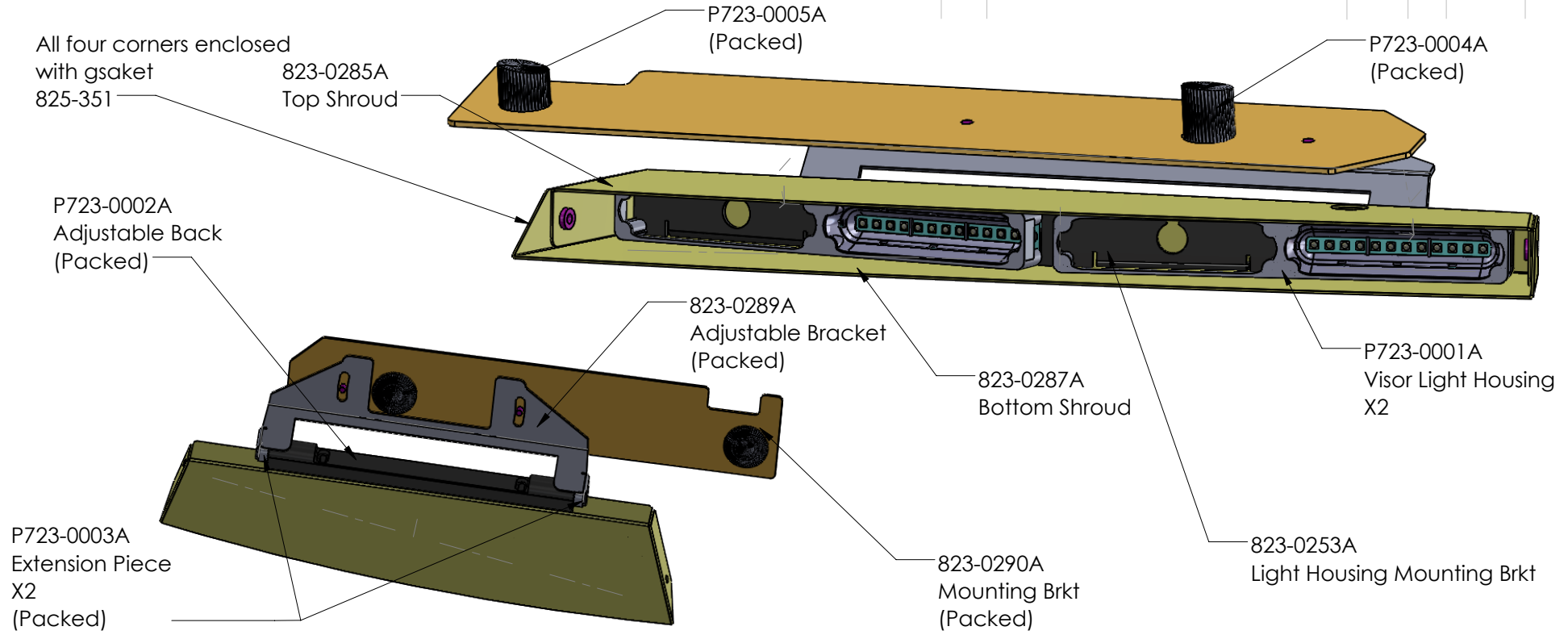

ASSEMBLY HARDWARE LIST (Per side, Total x2)

Qty	Description	Part Number
2	10-32 Machine Screw 3/8" Zinc	401-0009
2	#10 Lock Washer Zinc	403-0010
2	#10 Flat Washer Zinc	401-0025
4	4-40 Flat Washer Zinc	403-0019
4	4-40 Nyloc Nut	422-0006

PACKING HARDWARE LIST (Per side, Total x2)

Qty	Description	Part Number
2	10-32 Machine Screw 5/8" Zinc	401-0052
2	#10 Lock Washer Zinc	403-0010
2	1/4-20 Hex Bolt 1" Zinc	401-0025
2	1/4-20 Star Washer Zinc	403-0011
2	10-32 Flat Washer Zinc	403-0007A
2	10-32 Low Profile Nyloc Nut Zinc	402-0031
2	1/4-20 Hex Nut Zinc	402-0005

FORM ONE AS SHOWN FOR DS 923-0110A
 AND ONE OPP AND FOR PS 923-0111A
 SECOND SHEET FOR PS REFERENCE

NAME	DATE	DESCRIPTION	SIZE
IM	01APR19	2018 Ford Transit Visor Light DS	A
AD	01APR19	Path: M:\MECH_DATA\923 LED Lighting\923-0110A - 2018 Ford Transit Visor\ File: 923-0110A Date: May-13-19 3:07:06 PM	
THE INFORMATION CONTAINED WITHIN THIS DRAWING IS PROPRIETARY AND CONFIDENTIAL. AND IS THE SOLE PROPERTY OF DandR ELECTRONICS CO. LTD. IT MAY NOT BE REPRODUCED AT WHOLE OR IN PART WITHOUT THE WRITTEN PERMISSION OF DandR ELECTRONICS CO. LTD.		2018 Ford Transit Visor Light DS MFG. NO. 923-0110A USED ON: 9XX-XXXX MATERIAL XXga CRS	DANDR-ANSI-A REV2 APRIL 1,2009 CATALOG. NO. XXX SHEET 1 OF 2 REV. 0

REV.	DESCRIPTION	DCR	BY	DATE	APPROVED

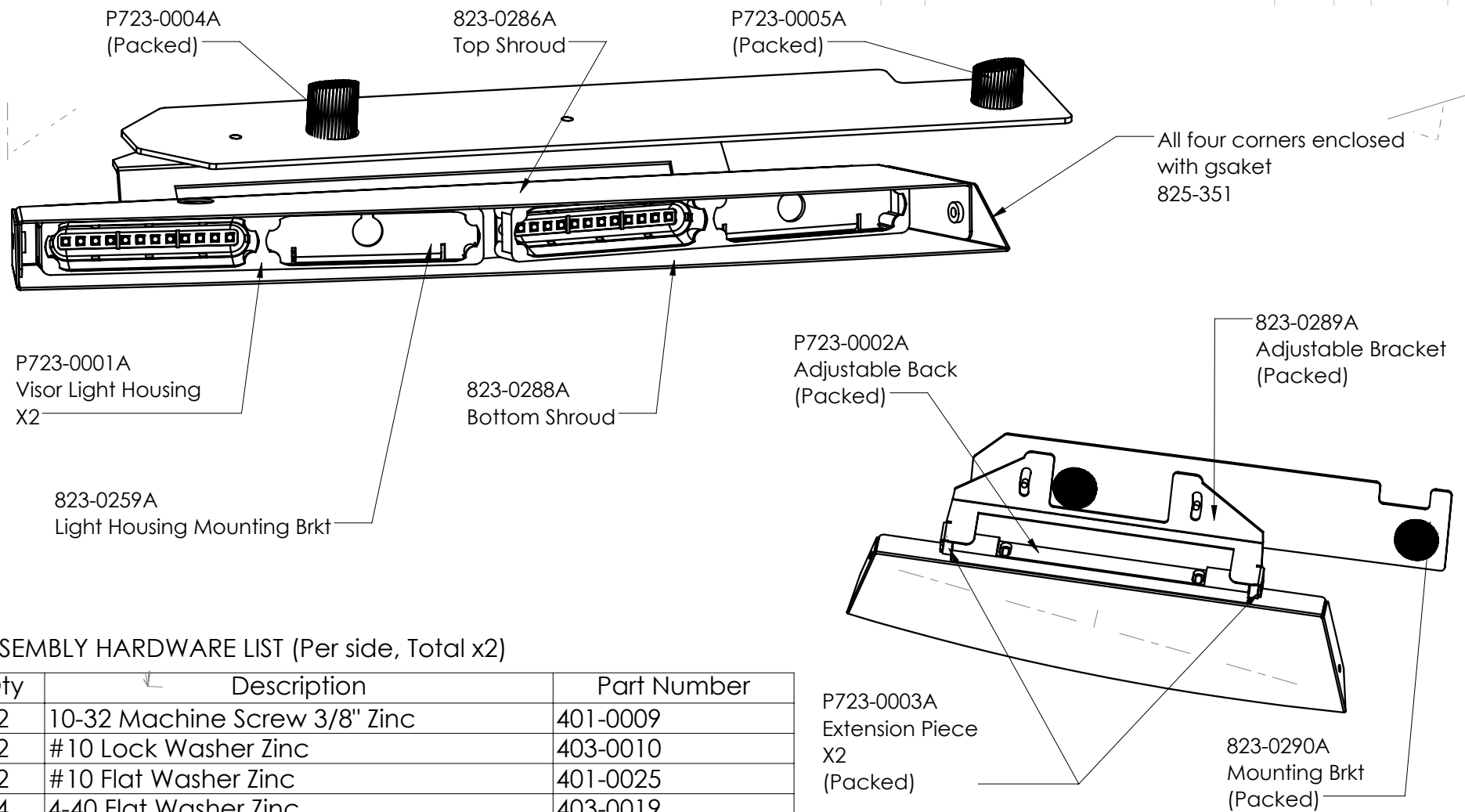

ASSEMBLY HARDWARE LIST (Per side, Total x2)

Qty	Description	Part Number
2	10-32 Machine Screw 3/8" Zinc	401-0009
2	#10 Lock Washer Zinc	403-0010
2	#10 Flat Washer Zinc	401-0025
4	4-40 Flat Washer Zinc	403-0019
4	4-40 Nyloc Nut	422-0006

PACKING HARDWARE LIST (Per side, Total x2)

Qty	Description	Part Number
2	10-32 Machine Screw 5/8" Zinc	401-0052
2	#10 Lock Washer Zinc	403-0010
2	1/4-20 Hex Bolt 1" Zinc	401-0025
2	1/4-20 Star Washer Zinc	403-0011
2	10-32 Flat Washer Zinc	403-0007A
2	10-32 Low Profile Nyloc Nut Zinc	402-0031
2	1/4-20 Hex Nut Zinc	402-0005

DRAWN	NAME	DATE	DESCRIPTION	DCR	REV	DATE	APPROVED	SIZE
IM	IM	01APR19	2018 Ford Transit Visor Light PS	AD	REV2	APRIL 1, 2009		A
CHECKED	AD	01APR19	Path: M:\MECH_DATA\923 LED Lighting\923-0110A - 2018 Ford Transit Visor\ File: 923-0110A Date: May-13-19 3:07:06 PM					
THE INFORMATION CONTAINED WITHIN THIS DRAWING IS PROPRIETARY AND CONFIDENTIAL. AND IS THE SOLE PROPERTY OF DandR ELECTRONICS CO. LTD. IT MAY NOT BE REPRODUCED AT WHOLE OR IN PART WITHOUT THE WRITTEN PERMISSION OF DandR ELECTRONICS CO. LTD.			2018 Ford Transit Visor Light PS		MFG. NO. 923-0111A	CATALOG. NO. XXX		
FINISH	XX		USED ON: 9XX-XXXX					SHEET 2 OF 2
			MATERIAL XXGa CRS					REV. 0