

REV.	DESCRIPTION	DCR	BY	DATE	APPROVED

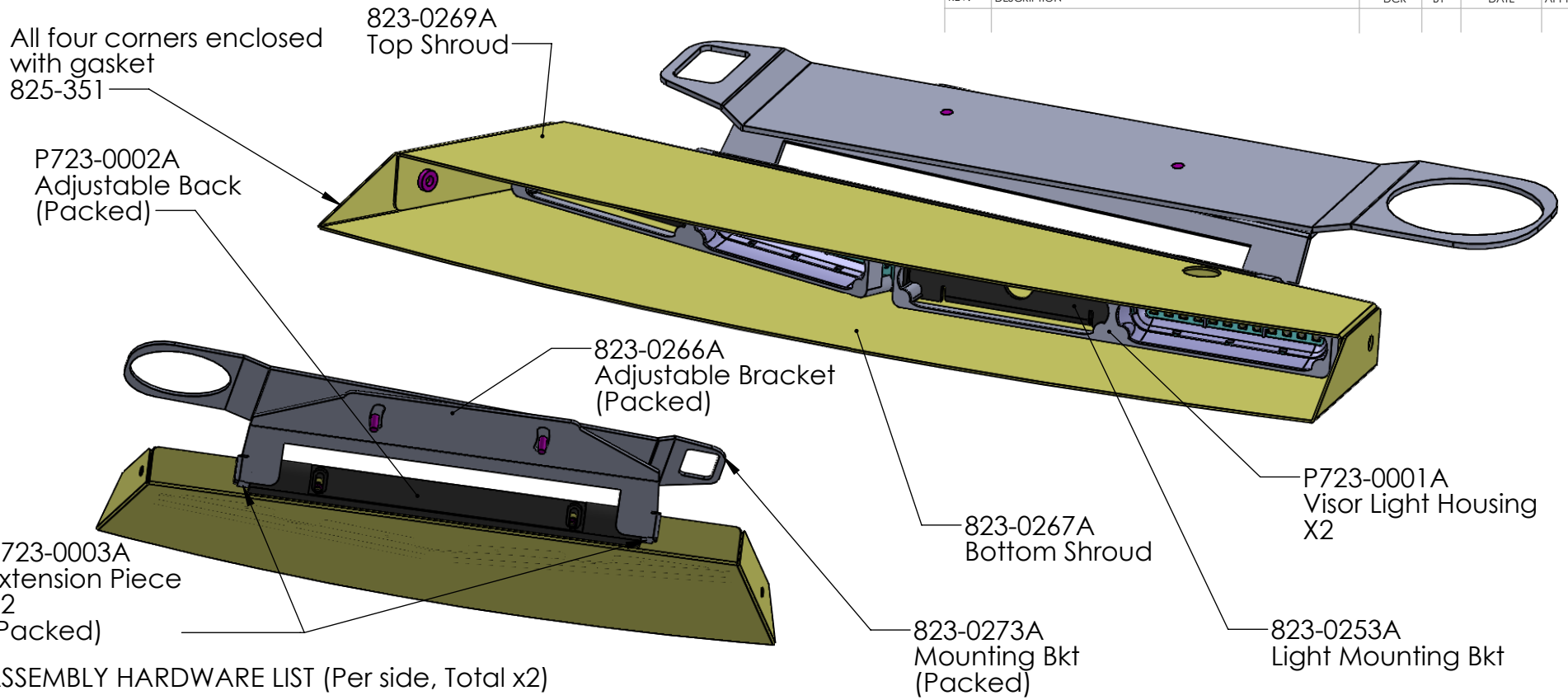

ASSEMBLY HARDWARE LIST (Per side, Total x2)

Qty	Description	Part Number
2	10-32 Machine Screw 3/8" Zinc	401-0009
2	#10 Lock Washer Zinc	403-0010
2	#10 Flat Washer Zinc	401-0025
4	4-40 Flat Washer Zinc	403-0019
4	4-40 Nyloc Nut	422-0006

PACKING HARDWARE LIST (Per side, Total x2)

Qty	Description	Part Number
2	10-32 Machine Screw 5/8" Zinc	401-0052
2	#10 Lock Washer Zinc	403-0010
2	1/4-20 Hex Bolt 1" Zinc	401-0025
2	1/4-20 Star Washer Zinc	403-0011
2	10-32 Flat Washer Zinc	403-0007A
2	10-32 Low Profile Nyloc Nut Zinc	402-0031
2	1/4-20 Hex Nut Zinc	402-0005

FORM ONE AS SHOWN FOR DS 923-0106A
AND ONE OPP HAND FOR PS 923-0107A
SECOND SHEET FOR PS REFERENCE

NAME	DATE	 DANDR-ANSI-A REV2 APRIL 1, 2009	SIZE
DRAWN	10SEP18		A
CHECKED	AD	10SEP18	Path: M:\MECH_DATA\923 LED Lighting\923-0106A - 2018 Ford Explorer Visor Light File: 923-0106A Date: April-02-19 3:33:15 PM
THE INFORMATION CONTAINED WITHIN THIS DRAWING IS PROPRIETARY AND CONFIDENTIAL. AND IS THE SOLE PROPERTY OF DandR ELECTRONICS CO. LTD. IT MAY NOT BE REPRODUCED AT WHOLE OR IN PART WITHOUT THE WRITTEN PERMISSION OF DandR ELECTRONICS CO. LTD.		DESCRIPTION: <h3>2018 Explorer Visor Light DS</h3>	
MFG. NO.	923-0106A	CATALOG. NO.	XXX
USED ON:	9XX-XXXX	SHEET 1 OF 1	
FINISH	XX	MATERIAL	XXga CRS
			REV. 0

REV.	DESCRIPTION	DCR	BY	DATE	APPROVED

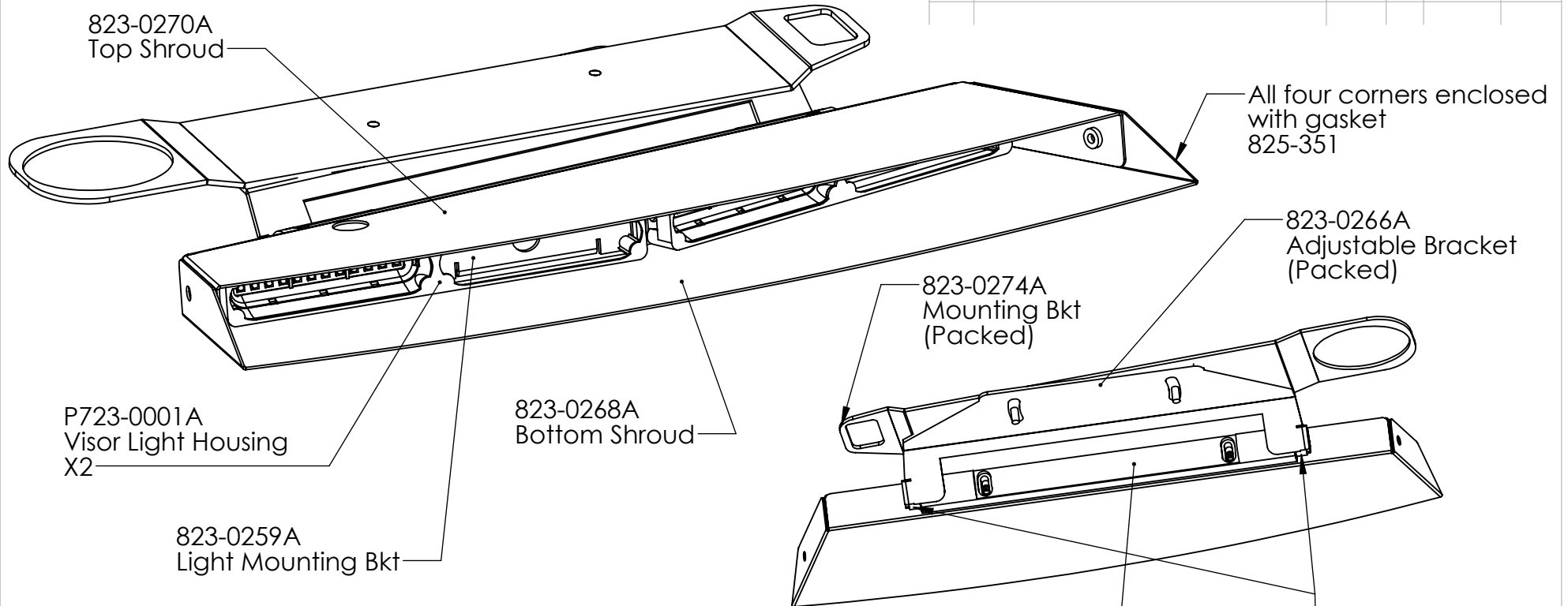

ASSEMBLY HARDWARE LIST (Per side, Total x2)

Qty	Description	Part Number
2	10-32 Machine Screw 3/8" Zinc	401-0009
2	#10 Lock Washer Zinc	403-0010
2	#10 Flat Washer Zinc	401-0025
4	4-40 Flat Washer Zinc	403-0019
4	4-40 Nyloc Nut	422-0006

PACKING HARDWARE LIST (Per side, Total x2)

Qty	Description	Part Number
2	10-32 Machine Screw 5/8" Zinc	401-0052
2	#10 Lock Washer Zinc	403-0010
2	1/4-20 Hex Bolt 1" Zinc	401-0025
2	1/4-20 Star Washer Zinc	403-0011
2	10-32 Flat Washer Zinc	403-0007A
2	10-32 Low Profile Nyloc Nut Zinc	402-0031
2	1/4-20 Hex Nut Zinc	402-0005

P723-0002A
Adjustable Back
(Packed)

P723-0003A
Extension Piece
X2
(Packed)

NAME	DATE	DCR	DESCRIPTION	REV	DATE	APPROVED	SIZE
IM	10SEP18	AD	10SEP18	1	APRIL 1, 2009		A
DRAWN		CHECKED		MFG. NO.		CATALOG. NO.	
AD		10SEP18		923-0107A		XXX	
THE INFORMATION CONTAINED WITHIN THIS DRAWING IS PROPRIETARY AND CONFIDENTIAL. AND IS THE SOLE PROPERTY OF DandR ELECTRONICS CO. LTD. IT MAY NOT BE REPRODUCED AT WHOLE OR IN PART WITHOUT THE WRITTEN PERMISSION OF DandR ELECTRONICS CO. LTD.				USED ON:		SHEET 1 OF 1	
FINISH				MATERIAL		REV.	
XX				XXga CRS		0	

2018 Explorer Visor Light PS

MFG. NO. 923-0107A CATALOG. NO. XXX
USED ON: 9XX-XXXX

REV.	DESCRIPTION	DCR	BY	DATE	APPROVED

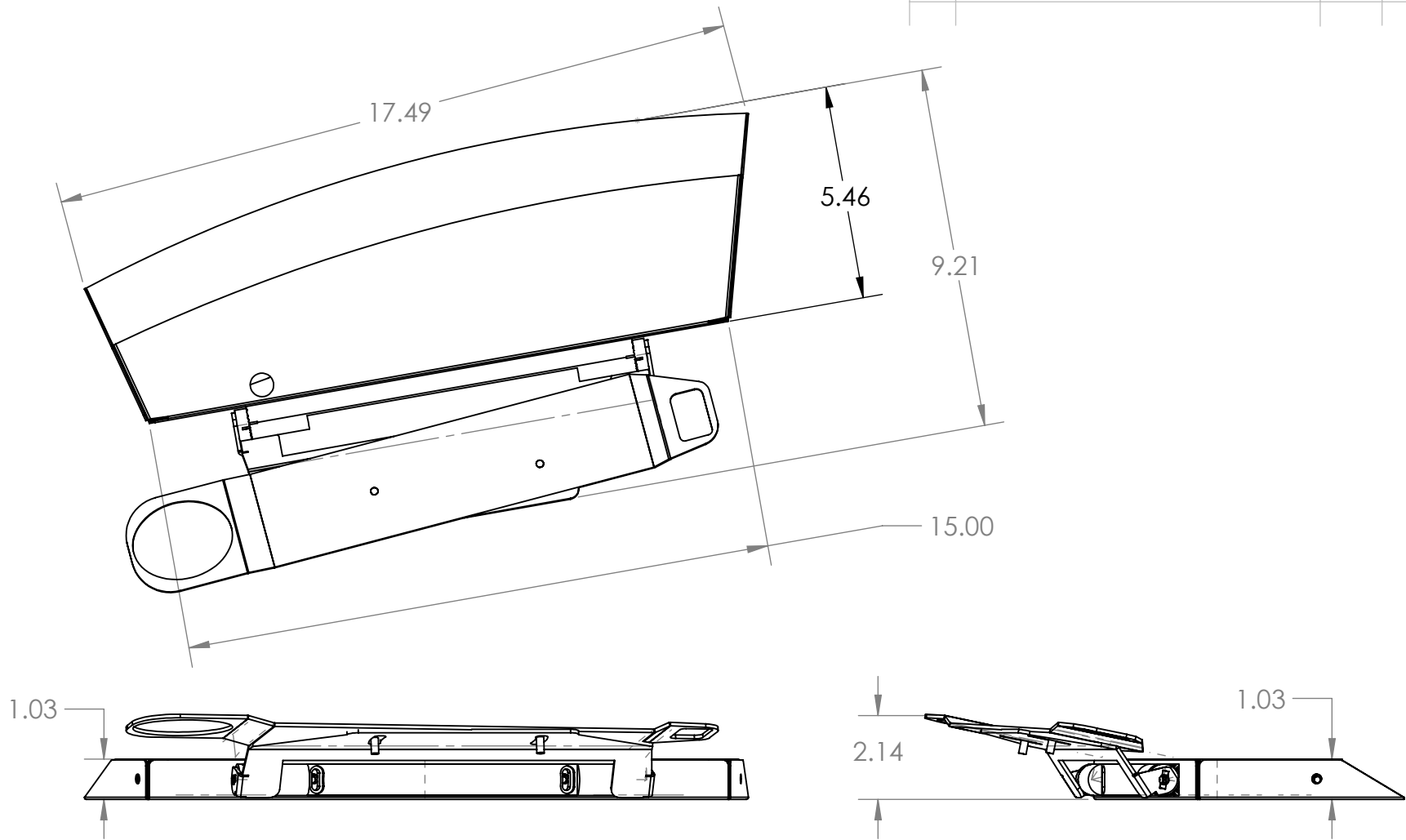

	NAME	DATE	 DANDR-ANSI-A REV2 APRIL 1, 2009	SIZE
DRAWN	IM	10SEP18		A
CHECKED	AD	10SEP18	Path: M:\MECH_DATA\923 LED Lighting\923-0106A - 2018 Ford Explorer Visor Light File: 923-0106A Date: April-02-19 3:33:15 PM	
THE INFORMATION CONTAINED WITHIN THIS DRAWING IS PROPRIETARY AND CONFIDENTIAL. AND IS THE SOLE PROPERTY OF DandR ELECTRONICS CO. LTD. IT MAY NOT BE REPRODUCED AT WHOLE OR IN PART WITHOUT THE WRITTEN PERMISSION OF DandR ELECTRONICS CO. LTD.			DESCRIPTION: 2018 Explorer Visor Light DS	
FINISH			MFG. NO.	CATALOG. NO.
XX			923-0106A	XXX
			USED ON:	SHEET 1 OF 1
			9XX-XXXX	
			MATERIAL	REV.
			XXga CRS	0