

2020 Utility Glovebox Printer Bracket Installation Manual (918-0051A)

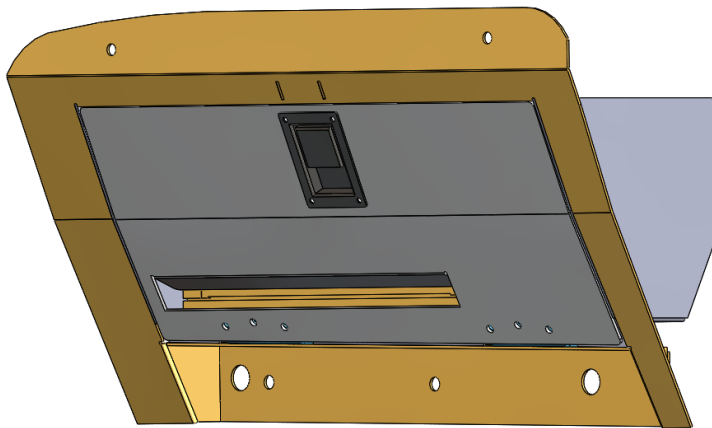

CLOSED

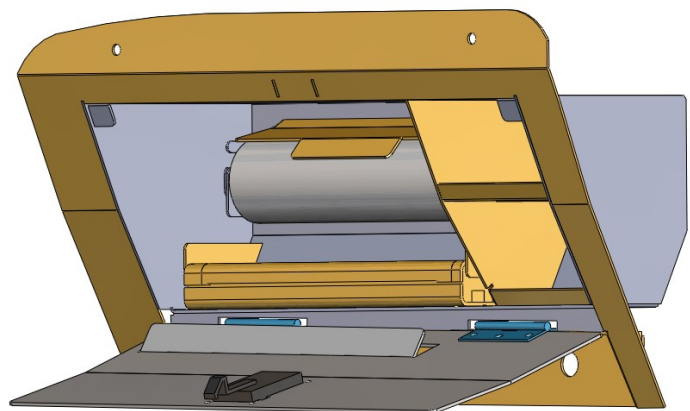

OPENED

Content	Page
Installation Instructions	2-3
Warranty and Return Policy	4

Installation Instructions:

Removing Factory Glovebox

Step 1.0

Open the factory glovebox and push in the two clips located each side.



Step 1.1

Detach the side support by pulling in towards you and then remove from hole to let door fall completely.

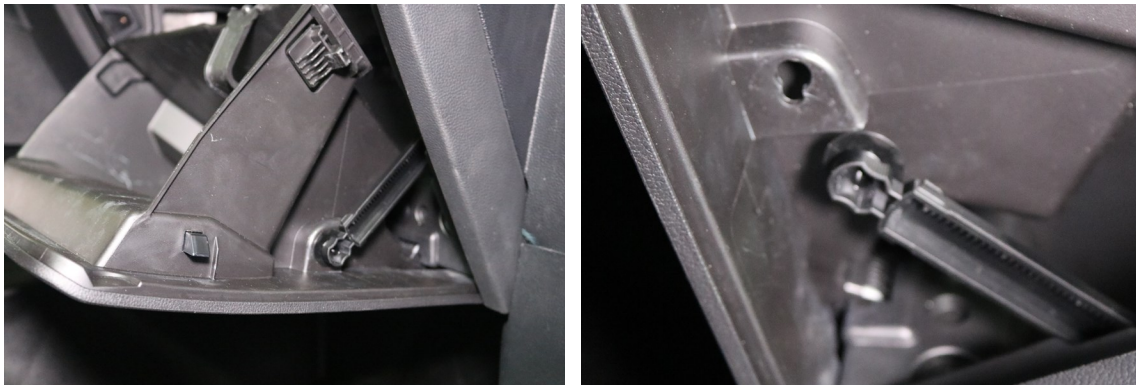

Step 1.2

Unfasten the five screws located as shown and then remove factory glovebox. Retain the screws for the next step.

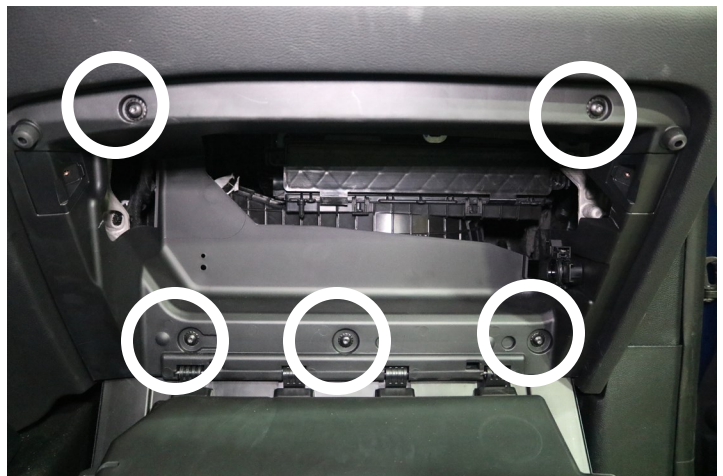

Installation the New Glovebox

Step 2.0

Insert the new glovebox in the space where the factory glovebox once was installed. Run power and data cord through the hole at the back of the glovebox. Secure the glovebox with the screws retained from Step 1.2 in the same locations.

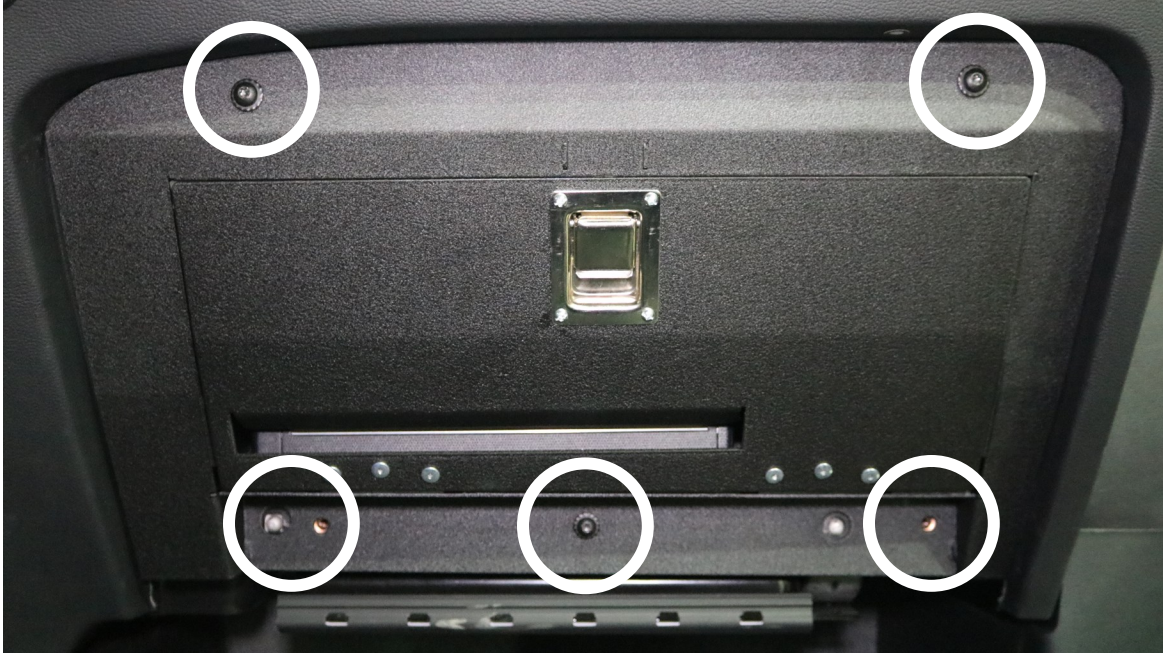

Installation is now complete.

WARRANTY

D & R Electronics warrants its new products to be free from defects in material and workmanship, under normal use and service, for a period of one year on parts replacement, and one year on labor.

This warranty applies only to original purchasers acquiring the product directly from D&R Electronics, or its authorized dealers. Warranty will not be recognized without proof of purchase or bill of sale. This warranty is not transferable.

The warranty begins on the date of delivery to the first user/purchaser. This warranty shall not apply to products which must be repaired due to normal wear and tear, negligence, improper installation, abuse, misuse, or which have been

altered or modified at a facility other than D & R Electronics, or its authorized depot center. Units proved to be defective within the warranty period, based on an examination by D&R Electronics, will be replaced or repaired at D & R Electronics' option. This warranty does not cover travel expenses or labor charges for removal or installation. Lamps, flash tubes, batteries or other items considered consumables are not covered under warranty.

This warranty is in lieu of all other express warranties. D&R Electronics makes no other warran-

PRODUCT RETURN POLICY

In order to provide you with faster service, product returns for repair or replacement, must have a **Return Goods Authorization Number (RGA number)**. Please contact our company to obtain a RGA number before you return the product to D & R ELECTRONICS. Write the RGA number clearly on the package. Be sure you use sufficient packing materials to avoid damage to the product being returned while in transit.

D & R ELECTRONICS assumes no responsibility or liability for expenses incurred for the removal and/or the installation of products requiring service and/or repair. Repairing or replacing product is at the

D&R ELECTRONICS Co. LTD.

CANADA

8820 George Bolton Pkwy.
Bolton, Ontario L7E 2Y4

Tel.: (905)951-9997
Fax: (905)951-0019

USA

2299 Kenmore Ave
Building #3, Doors 11-14
Buffalo, NY, 14207

Toll Free 1-800-538-7338

www.dandrelectronics.com