

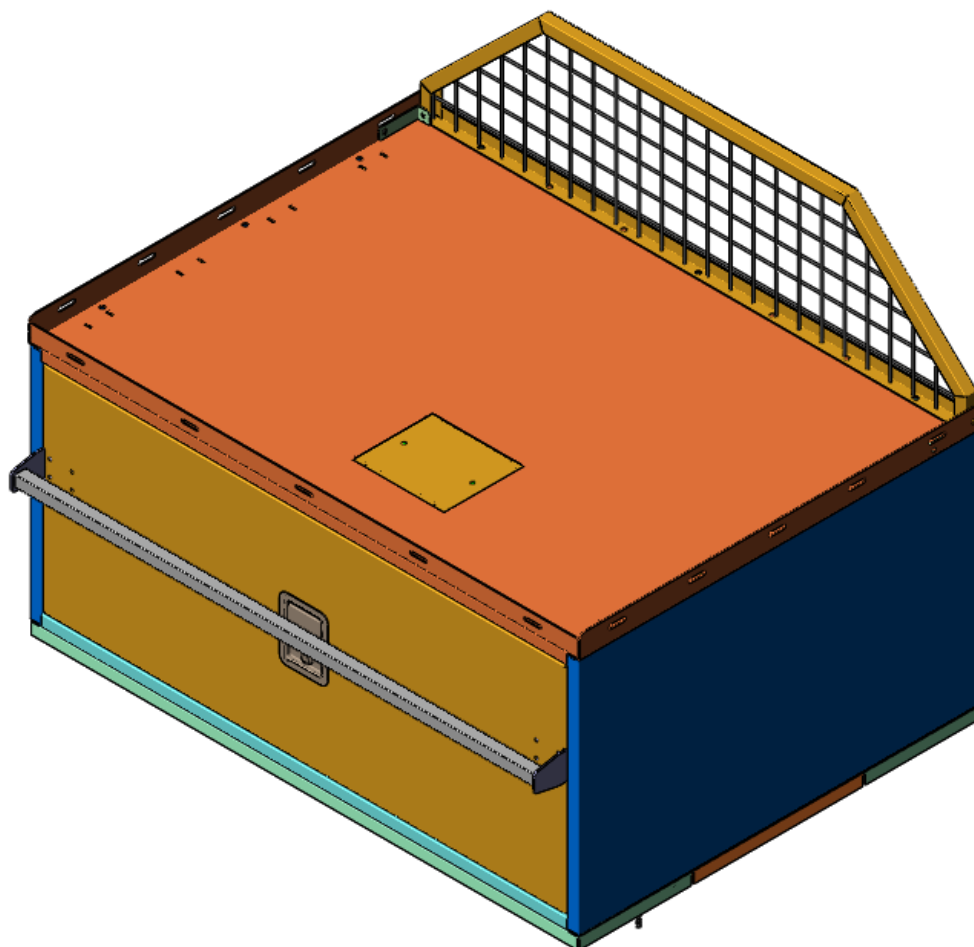

# 934-0485A Custom Tahoe Storage

## INSTALLATION MANUAL



### CONTENTS

Unpacking	—	2
Installation	—	2
Warranty	—	6
Return Policy	—	6

## UNPACKING

Before beginning any installation, unpack the equipment received. After unpacking, examine **ALL** components received for any damage that may have occurred while in transit. If any damage has occurred, file a claim **IMMEDIATELY** with the courier stating the extent of damage. Check **ALL** envelopes, packing slips, shipping labels and tags before removing or destroying them.

To ensure your satisfaction, open all cartons and report any shortages **within 48 hours of receipt.**

HARDWARE PARTS LIST: FOR MOUNTING CABINET

Quantity	Description
4	3/8 x 1" Hex Bolt
4	3/8, Lock Washer
4	3/8, WASHER
4	1/4-20 x 1/2" Hex Bolt
4	1/4-20 Washer
4	1/4-20 Nylock Nut

## VEHICLE PREPARATION

Install the Vehicle Specific Sub frame in the vehicle. Refer to the Sub frame Installation instructions for installing the Sub frame.

## INSTALLATION OF STORAGE UNIT

### Step 1

#### Remove Cabinet Top

Remove all the Bolts located on the top of the cabinet and carefully lift the cabinet top and place aside.

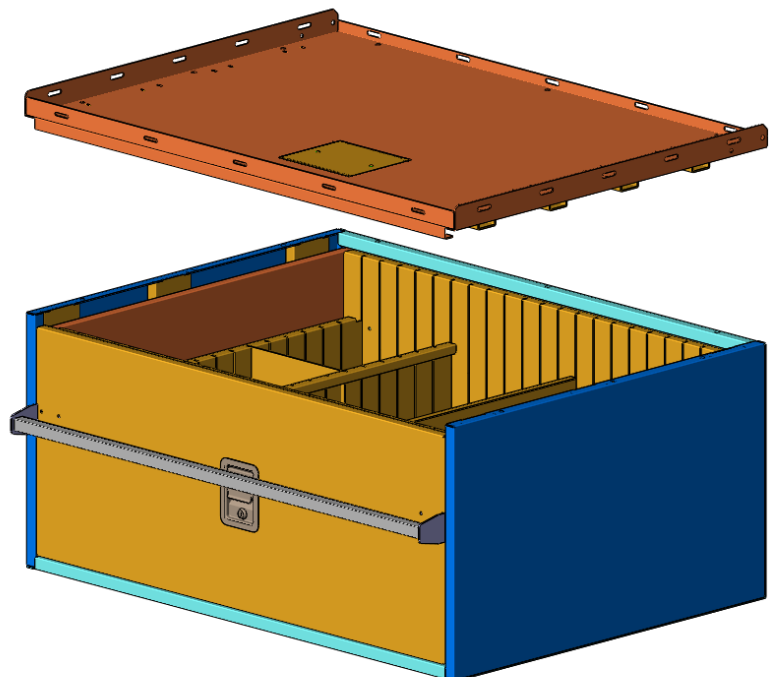

## Step 2

### Check Mounting location points

Carefully open the drawer. Measure and evaluate the mounting locations of the cabinet. There are four mounting locations.

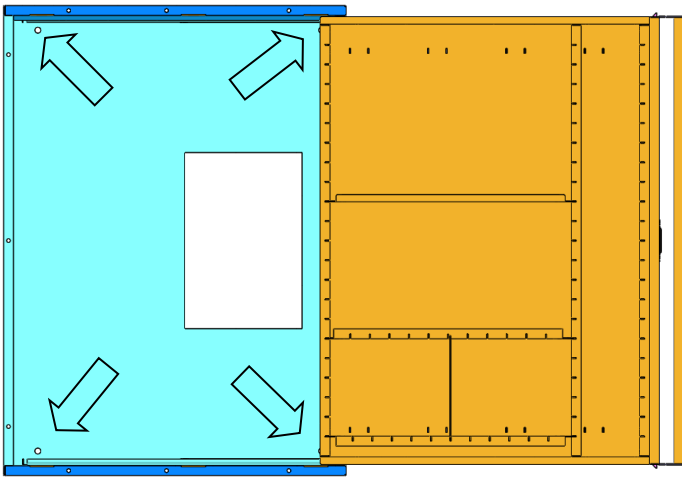
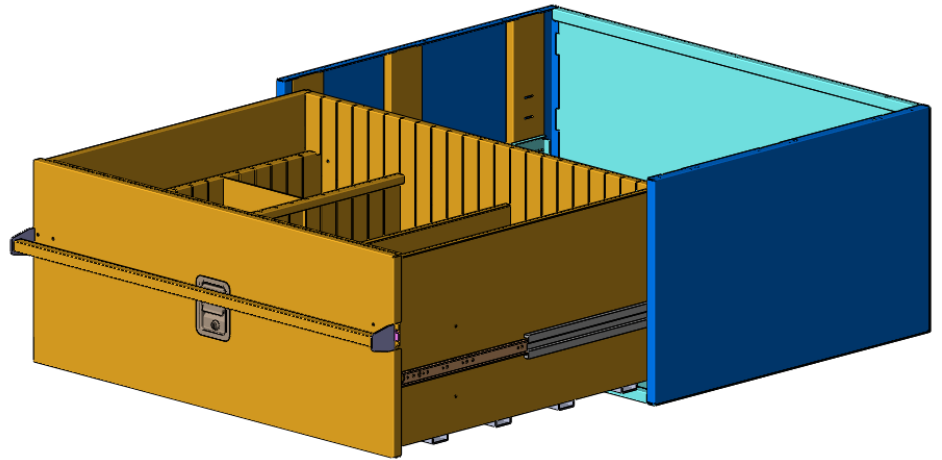

## Step 3

### Place Retainer Nuts on Sub frame

Place Retainer Nuts on Sub frame based on the mounting locations found in Step 2..

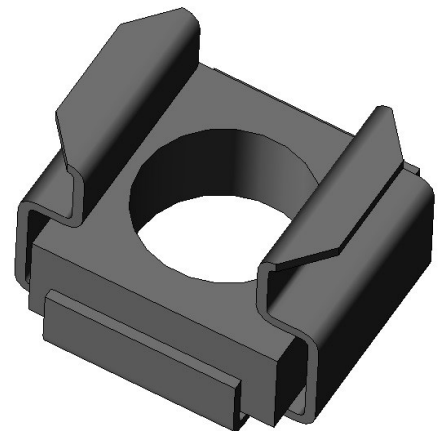

## Step 4

### Place Cabinet on Subframe

Carefully place Cabinet on Sub frame and Secure using 3/8 X 1" Hex Bolts, 3/8" Lock Washers and 3/8" Washers on locations found in Step 2.

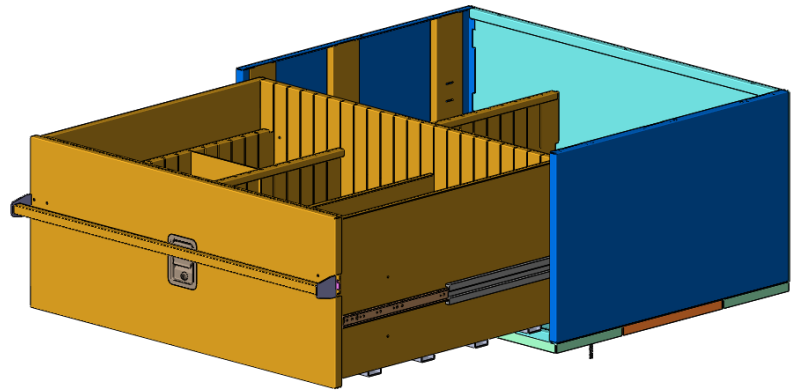
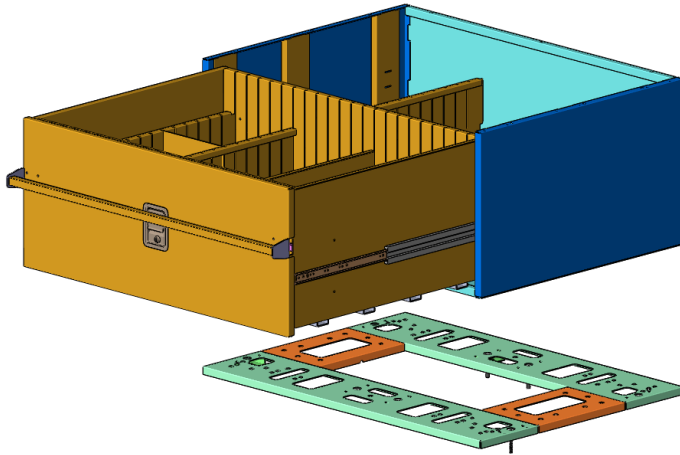

## Step 5

### Close the Drawers

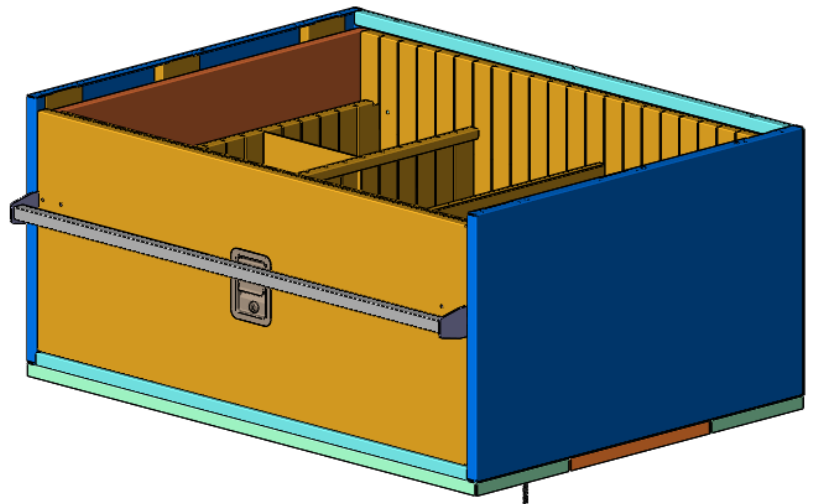

## Step 6

Replace the Cabinet Top, replace front four bolts and washers removed in Step 1.

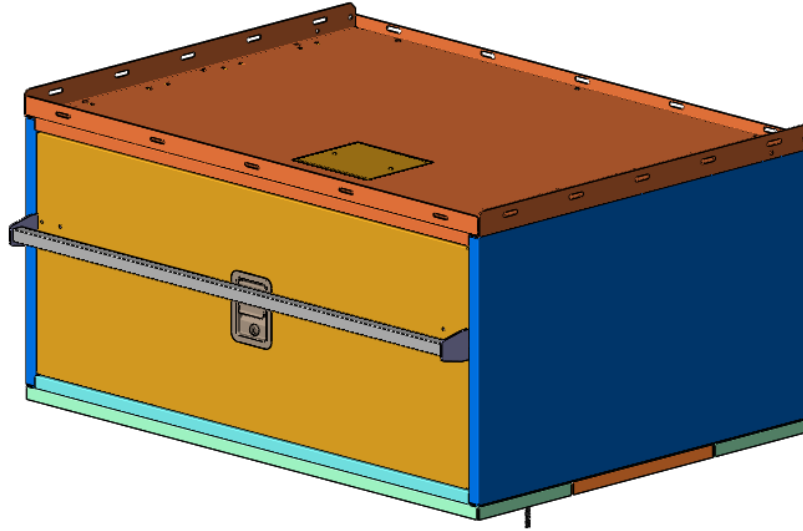

## Step 7

### Cargo Partition

Insert Cargo partition and cargo partition bracket. Replace the remainder of the top hardware to attach the partition to the cabinet. Arrow pointing to side bolt location, 1 on each side 2x 1/4-20 x 1/2 Hex bolt, 2pc Flat washer and 1/4-20 Nyloc Nut.

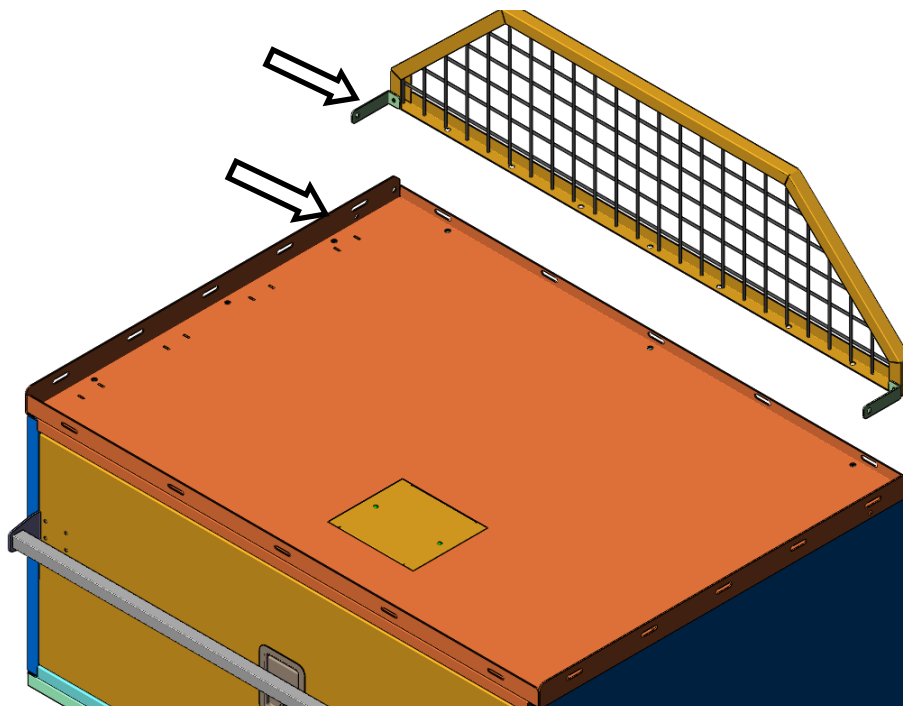

## WARRANTY

D & R Electronics warrants its new products to be free from defects in material and workmanship, under normal use and service for a period of one year on parts replacement and one year on labor.

This warranty applies only to original purchasers acquiring the product directly from D&R Electronics, or its authorized dealers. Warranty will not be recognized without proof of purchase or bill of sale.

This warranty is not transferable.

The warranty begins on the date of delivery to the first user/purchaser.

This warranty shall not apply to products which must be repaired due to normal wear and tear, negligence, improper installation, abuse, misuse, or which have been altered or modified at a facility other than D & R Electronics, or its authorized depot centers.

Units proved to be defective within the warranty period, based on an examination by D&R Electronics, will be replaced or repaired at D & R Electronics' option. This warranty does not cover travel expenses or labor charges for removal or installation.

Lamps, flash tubes, batteries or other items considered consumables are not covered under warranty.

This warranty is in lieu of all other express warranties. D&R Electronics makes no warranties, expressed or implied, other than the express warranties contained herein.

## PRODUCT RETURN POLICY

In order to provide you with faster service, product returns for repair or replacement, must have a **Return Goods Authorization Number (RGA number)**. Please contact our company to obtain a RGA number before you return the product to D & R ELECTRONICS. Write the RGA number clearly on the package. Be sure you use sufficient packing materials to avoid damage to the product being returned while in transit.

D & R ELECTRONICS assumes no responsibility or liability for expenses incurred for the removal and/or the installation of products requiring service and/or repair.

**Repairing or replacing product is at the discretion of D & R ELECTRONICS.**

### D&R ELECTRONICS Co. LTD.

#### CANADA

8820 George Bolton Pkwy.  
Bolton, Ontario L7E 2Y4

Tel.: (905)951-9997

Fax: (905)951-0019

#### USA

2321 Kenmore Ave.  
Buffalo, NY 14207

Toll Free 1-800-538-7338

[www.dandrelectronics.com](http://www.dandrelectronics.com)