

## F5M-IQ INSTALLATION MANUAL



Model F5M-IQ1  
F5M-IQ2



**IMPORTANT:** Carefully read ALL instructions and warnings before attempting to install and operate this equipment.

# TABLE OF CONTENTS

<b>1—UNPACKING &amp; PRE-INSTALLATION CHECK.....</b>	<b>Page 3</b>
<b>2—SAFETY CONSIDERATIONS.....</b>	<b>Page 3</b>
<b>3—SPECIFICATIONS.....</b>	<b>Page 4</b>
<b>4—INSTALLATION.....</b>	<b>Page 5</b>
<b>5—LABELING INSTRUCTIONS.....</b>	<b>Page 6</b>
<b>6—F5M-IQ DEFAULT CONFIGURATION.....</b>	<b>Page 7</b>
<b>7—F5M-IQ TOUCHPAD PROGRAMMING.....</b>	<b>Page 8</b>
<b>8—F5M-IQ VOLTAGE CALIBRATION.....</b>	<b>Page 8</b>
<b>9—F5M-IQ TEMPERATURE CALIBRATION.....</b>	<b>Page 9</b>
<b>10—F5M-IQ TOUCHPAD BACKLIGHT QUICK SETTING.....</b>	<b>Page 9</b>
<b>11—IMAGES.....</b>	<b>Page 10</b>
<b>REAR VIEW CONNECTORS LAYOUT.....</b>	<b>Page 10</b>
<b>FRONT VIEW CONNECTORS LAYOUT.....</b>	<b>Page 11</b>
<b>TOP VIEW (FUSES AND LED INDICATORS).....</b>	<b>Page 11</b>
<b>12—TOUCHPAD SETUP FILE UPLOAD ERROR CODES.....</b>	<b>Page 11</b>
<b>13—WARRANTY &amp; PRODUCT RETURN POLICY.....</b>	<b>Page 12</b>

## 1. Unpacking & Pre-Installation Check

D&R Electronics Co. recommends that you open and examine all shipments within **48 hours of receipt**. The *INTIMIDATOR IQ* systems are shipped pre-assembled and factory tested. All necessary hardware for standard installation is included. Use this pre-installation check list to verify your unit:

1. Confirm contents with the packing slip
2. Examine unit for damaged in transit (i.e. scratches, broken or bent connectors. etc.).

If any damage has occurred, file a claim **IMMEDIATELY** with the courier stating the extent of damage. Check **ALL** envelopes, packing slips, shipping labels and tags before removing or destroying them.

## 2. Safety Considerations

The effectiveness of this system is highly dependent upon its proper installation. Please read and follow ALL instructions provided in this manual before attempting the installation.

For proper installation of this product you must have a good understanding of automotive electrical systems and procedures, as well as proficiency in installation and servicing of emergency vehicle sound, lighting and warning equipment. We recommend this equipment be installed only by qualified personnel.

### **WARNING!**

The D&R Electronics INTIMIDATOR siren/light controller is an advanced microprocessor based system. Unlike conventional systems, malfunctions and/or improper operation will result if proper installation procedures are not followed. Refer to any accompanying diagrams and pay particular attention to WARNINGS, CAUTIONS and HAZARDS listed in this document. Follow instructions exactly as shown where so indicated.

### **HEARING HAZARDS!**

Your hearing and that of others, in or near the emergency vehicle could be affected by the very loud emergency sounds generated. **Hearing loss or damage could result due to short-term exposure to excessively loud sounds!** Each jurisdiction (country, province/state, etc.) has specific regulations governing exposure to sound. During installation and testing it is recommended that anyone working in the vicinity of the vehicle to wear approved hearing protection devices.

- DO NOT connect this system to vehicle battery until all other electrical connections have been completed, and have been checked that no short-circuits exist.
- When passing wire through compartment walls and drilling holes is required, the installer **MUST** check both sides of the drilling surface before drilling. Make sure that no vehicle components could be damaged by the drilling operation. Clean the holes and remove any burrs. Use a grommet of appropriate size and sealants when passing the wires through the compartment walls.
- Looms, grommets, cable ties or other installation hardware should be used to anchor and protect wires.
- Splices should be minimized and made in a fashion so as to protect them from corrosion to minimize the possibility of loss of conductivity over time.
- **INSTALLATION OF ALL EQUIPMENT AND WIRING SHALL NOT OBSTRUCT, IMPEDE OR INTERFERE WITH THE DEPLOYMENT OF VEHICLE AIR BAGS, OTHERWISE IT COULD POSSIBLY REDUCE THE EFFECTIVENESS THE AIR BAG SYSTEM CAUSING SERIOUS INJURY (OR EVEN DEATH) IN THE EVENT OF AN ACCIDENT.**
- If using non-D&R Electronics components, such as speaker(s), be sure that they are properly rated for the system you are installing.
- All speakers should be installed in a location that will produce minimum sound levels inside the vehicle, while maximizing the warning signal effectiveness to oncoming traffic on the exterior of the vehicle.
- This device is intended for use by authorized personnel only. The user responsibility is to ensure that all local, state/provincial and federal laws are being complied with. D&R assumes no liability for any loss resulting from the use of this device.

### 3. Specifications

#### General

Input Voltage .....	11 to 16 Volts DC
Input Fuse .....	60 Amps (external)
Operating Temperature Ranges .....	-40°C to +65°C
Standby Current .....	50mA $\pm$ 10% during IGNITION OFF time-out
.....	$\emptyset$ mA after time-out

#### Control Box Weight

Single Siren.....	5.34lb / 2.42kg
Dual Siren.....	7.12lb / 3.23kg

#### Control Box Physical Dimensions

Height .....	2 - 1/16" (68mm)
Width .....	6 - 3/8" (161mm)
Length .....	8 - 5/8" (218mm)

#### Siren

Operating Current .....	10 Amps—Single Amplifier
Frequency Range .....	700 to 1640 Hz (nominal)
Cycle Rate	
Wail .....	20 cycles/min
Yelp .....	200 cycles/min
Stinger .....	800 cycles/min
Nominal Voltage Output .....	52V p-p (11 $\Omega$ load)
Audio Frequency Response .....	100 – 4000 Hz $\pm$ 3dB
Audio Distortion .....	10% or less
Audio Output Power .....	32 watts
Siren Output Power.....	100 Watts

**NOTE: TOTAL current draw not to exceed 60A including siren**

#### Current Outputs

##### **PLUG 1**

Pin 4.....OUTPUT #1..... 20 Amp Max. (fused 20A)

##### **PLUG 2**

Pin 2.....OUTPUT #1.....10 Amp Max. (fused 15A)

Pin 3.....OUTPUT #2.....10 Amp Max. (fused)

Pin 4.....OUTPUT #3.....10 Amp Max. (fused)

Pin 5.....OUTPUT #4.....10 Amp Max. (fused)

Pin 6.....OUTPUT #5.....10 Amp Max. (fused)

Pin 7.....OUTPUT #6.....10 Amp Max. (fused)

Pin 8.....OUTPUT #7.....10 Amp Max. (fused)

Pin 9.....OUTPUT #8.....10 Amp Max. (fused)

##### **PLUG 3**

Pin 1.....OUTPUT #9.....2 Amp Max.

Pin 2.....OUTPUT #10.....2 Amp Max.

Pin 3.....OUTPUT #11.....2 Amp Max.

Pin 4.....OUTPUT #12.....2 Amp Max.

Pin 5.....OUTPUT #13.....2 Amp Max.

Pin 6.....OUTPUT #14.....2 Amp Max.

Pin 7.....OUTPUT #15.....2 Amp Max.

Pin 8.....OUTPUT #16.....2 Amp Max.

Pin 9.....OUTPUT #17.....2 Amp Max.

Pin 10.....OUTPUT #18.....2 Amp Max.

Pin 11.....OUTPUT #19.....2 Amp Max.

Pin 12.....OUTPUT #20.....2 Amp Max.

**NOTE: Do not use both OUT 1 pins at the same time.**

## **4. Installation**

### **CONNECTOR #1**

**PIN 1** — Connect a BLACK 10 AWG wire to battery GROUND.

**PIN 2** — Connect a RED 10 AWG wire to the POSITIVE side of the battery, using a 60A breaker.

**PIN 3** — Connect a RED 10 AWG wire to the POSITIVE side of the battery, using the same 60A breaker as PIN 2.

**PIN 4** — OUTPUT 1, 20A MAX

**NOTE:** If this pin is used then OUTPUT 1 on CONNECTOR 2, PIN 2 cannot be used.

### **CONNECTOR #2**

**PIN 1** — Connect a 16 AWG wire to +12V IGNITION feed. This feed is used to turn ON the system.

**PIN 2** — OUTPUT 1, 10A MAX

**NOTE:** If this pin is used then OUTPUT 1 on CONNECTOR 1, PIN 4 cannot be used.

**PIN 3** — OUTPUT 2, 10A MAX

**PIN 4** — OUTPUT 3, 10A MAX

**PIN 5** — OUTPUT 4, 10A MAX

**PIN 6** — OUTPUT 5, 10A MAX

**PIN 7** — OUTPUT 6, 10A MAX

**PIN 8** — OUTPUT 7, 10A MAX

**PIN 9** — OUTPUT 8, 10A MAX

### **CONNECTOR #3**

**PIN 1** — OUTPUT 9, 2A MAX

**PIN 2** — OUTPUT 10, 2A MAX

**PIN 3** — OUTPUT 11, 2A MAX

**PIN 4** — OUTPUT 12, 2A MAX

**PIN 5** — OUTPUT 13, 2A MAX

**PIN 6** — OUTPUT 14, 2A MAX

**PIN 7** — OUTPUT 15, 2A MAX

**PIN 8** — OUTPUT 16, 2A MAX

**PIN 9** — OUTPUT 17, 2A MAX

**PIN 10** — OUTPUT 18, 2A MAX

**PIN 11** — OUTPUT 19, 2A MAX

**PIN 12** — OUTPUT 20, 2A MAX

**CONNECTOR #4** - expander control cable OUTPUT 21 to 30

**CONNECTOR #5** - expander control cable OUTPUT 31 to 40

**NOTE:** The expanders are optional modules in case extra outputs are needed. There are 2 different expander modules:

**IQEXP-LC** 10 OUTPUTS @ 2A each

**IQEXP-HC** 4 OUTPUTS @ 20A each & 6 OUTPUTS @ 10A each

## CONNECTOR #6

**PIN 1** — SIREN #1 SPEAKER  
**PIN 2** — SIREN #1 SPEAKER  
**PIN 3** — SIREN #2 SPEAKER (optional)  
**PIN 4** — SIREN #2 SPEAKER (optional)

**PIN 5** — HORN  
**PIN 6** — HORN RING

**PIN 7** — RADIO input  
**PIN 8** — RADIO input

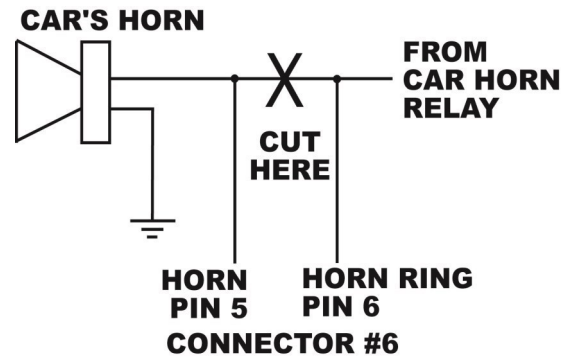

HORN / HORN RING relay connection

## CONNECTOR #7

**PIN 1, 9, 10** — N/A  
**PIN 2** — PARK KILL input, default GROUND control. Optional positive control, see the software manual.  
**PIN 3** — +12V input from battery, feed used to measure the battery voltage.  
**PIN 4 TO 8** — logic inputs, default +12V triggers. Optional programmable to GROUND triggers, see the software manual.

**CONNECTOR #8, 9, 11**— data input used to connect touchpad, lightbar or temperature sensors.

## RADIO VOLUME ADJUSTMENT

## MICROPHONE VOLUME ADJUSTMENT

## MICROPHONE JACK

## 5. LABELING INSTRUCTIONS

1. Using a Phillips screwdriver remove the 4 self-tapping screws securing the back cover of the touchpad.
2. Using a small flat screwdriver, carefully separate the front cover from the back cover.
3. Select the appropriate push button label from the enclosed label packet.
4. Orient the label in the same direction as the existing top row labels and with the top cover resting on a flat surface, evenly apply finger pressure to the label to ensure that it has been applied properly.
5. Apply all required remaining labels in the same manner.
6. When all required labels are installed, re-install the front cover and carefully tighten the self tapping screws securing the back cover.



## 6. F5M-IQ DEFAULT TOUCHPAD CONFIGURATION

The touchpad setup is a standard factory default. For setup changes refer to the software manual for programming. The labels can be rearranged as per customer's preference.

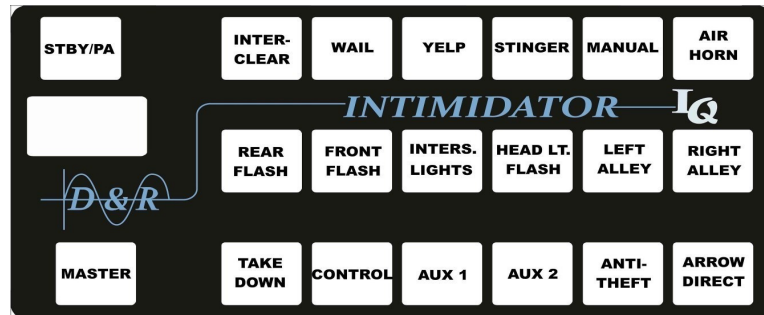

**STBY/PA** — Momentary AIR HORN (optional can be programmed to momentary WAIL).

**INTER-CLEAR** — Activates the INTER-CLEAR tone.

**NOTE:** - Activates the MULTI-TONE tone when the system is configured with dual siren amplifier.

**WAIL** — Activates the WAIL tone.

**YELP** — Activates the YELP tone.

**STINGER** — Activates the STINGER tone

**MANUAL** — Activates momentary the WAIL tone.

**AIR HORN** — Activates momentary the AIR HORN tone.

**HANDS FREE**— The Hands-Free mode is activated when STBY or any of the siren buttons is ON. A first press of the horn ring it will activate the WAIL tone. A second press it will activate the YELP tone. A third press it will activate the STINGER tone. A fourth press it will activate again the WAIL tone. This cycle continues until the user deactivates the Hands-Free mode. Pressing the horn ring twice, in a quick succession, when STBY is selected it will turn OFF the siren tone and sets the system into Hands -Free ready mode. Pressing the horn ring twice , in a quick succession, when any of the siren tones is selected it will turn OFF the siren. Turning OFF the STBY or any of the siren buttons will turn OFF the siren tone and deactivates the Hands-Free mode.

**REAR FLASH** — Activates Output 1 continuous ON and the rear of the lightbar

**FRONT FLASH** — Activates Output 2 continuous ON and the front of the lightbar.

**INTERSECTION LIGHTS** — Activates Output 3 continuous ON and the intersection of the lightbar.

**HEAD LT. FLASH** — Activates Output 4 & 5 flashing.

**LEFT ALLEY** — Activates Output 6 continuous ON and the left alley of the lightbar.

**RIGHT ALLEY** — Activates Output 7 continuous ON and the right alley of the lightbar.

**MASTER** — Activates STBY, REAR FLASH, FRONT FLASH, INTERSECTION LIGHTS buttons.

**TAKE DOWN** — Activates Output 8 continuous ON and the take down of the lightbar.

**CONTROL** — Activates Output 9 as 9 second timer, with IGNITION ON only.

**AUX 1** — Activates Output 10 continuous ON.

**AUX 2** — Activates Output 11 continuous ON.

**ANTI-THEFT** — Activates Output 12 MOMENTARY, with IGNITION ON only.

**ARROW DIRECT** — Activates Output 13 & Output 14 as 2 trigger traffic director:

LEFT ARROW—Output 13 continuous ON

RIGHT ARROW—Output 14 continuous ON

CENTER OUT—Output 13 & Output 14 continuous ON



## 7. F5M-IQ TOUCHPAD PROGRAMMING

The F5M-IQ system provides access to the following features: display intensity, push-buttons backlight intensity, push-buttons ON light intensity through touchpad programming

To make settings adjustments follow these steps:

- Step 1: Press and hold down SW8 and SW10.
- Step 2: Enter "BACKLIGHT" setup.  
To adjust press SW9 to decrease, SW10 to increase.  
Press SW8 to save and move to next function.
- Step 3: Enter "KEYBRIGHT" setup.  
To adjust press SW9 to decrease, SW10 to increase.  
Press SW8 to save and move to next function.
- Step 4: Enter "DISPBRIGHT" setup.  
To adjust press SW9 to decrease, SW10 to increase.  
Press SW8 to save and exit programming



## 8. F5M-IQ VOLTAGE CALIBRATION

The F5M-IQ system provides a continuous battery voltage reading on the touchpad's display. After a set-up update, the display will show "Voltage 0V" even though the voltage input is connected to the battery. The system needs a voltage reading calibration.

To make adjustments follow these steps:

- Step 1: Using a multi-meter measure the input voltage in the IQ system.
- Step 2: Press and hold down SW8 and SW10.
- Step 3: Enter "BACKLIGHT" setup.  
Continue to hold down SW8 and release SW10.
- Step 4: Enter "RELAYBOX INPUTS" status. Release SW8.  
Press SW8 to save and move to next step.
- Step 5: Enter "LIGHTBAR INPUTS" status.  
Press SW8 to save and move to next step.
- Step 6: Enter "CALIBRATION VOLTAGE".  
Adjust the voltage on the display to match the voltage measured in Step 1. Use SW9 to increase and SW10 to decrease value.  
Press SW8 to save and exit voltage calibration.

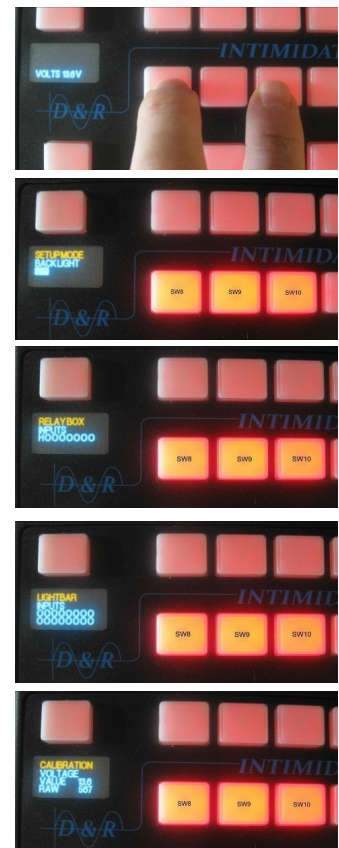



## **9. F5M-IQ TEMPERATURE CALIBRATION (optional equipment)**

The F5M-IQ system provides an optional connection for up to 3 temperature sensor modules.

To calibrate the temperature follow these steps:

- Step 1: Using a thermometer, record the temperature were the temperature sensor is installed.
- Step 2: Repeat *Step 2* to *Step 6* from previous section: **“8. F5M-IQ VOLTAGE CALIBRATION”** .
- Step 3: Enter “CALIBRATION TEMPESENSOR 1”.  
Adjust the temperature on the display to match the temperature measured in *Step 1*.  
Use SW9 to increase and SW10 to decrease value.
- Step 4: Press SW8 to save.  
If a second temperature sensor is present, repeat *Step 3* to calibrate *TempSensor 2*.  
If not, the system will exit temperature calibration process.
- Step 5: Press SW8 to save.  
If the third temperature sensor is present, repeat *Step 3* to calibrate *TempSensor 3*.  
If not, the system will exit temperature calibration process.
- Step 6: Press SW8 to save and exit temperature calibration.

## **10. F5M-IQ TOUCHPAD BACKLIGHT QUICK SETTING**

The F5M-IQ system provides a 6 level quick adjustment for the touchpad backlight.

To make a quick adjustment of the touchpad backlight follow these steps:

- Step 1: Press and hold down SW1.
- Step 2: After 3 seconds the backlight quick adjustment is enabled. Keep holding down SW1.
- Step 3: Every couple of seconds the touchpad will beep and change the backlight to the next intensity level. Once the highest level is reached it will start a new cycle by selecting the lowest backlight level.
- Step 4: Once the desired backlight level is selected, release SW1. The new backlight level is saved and the touchpad will resume the normal operation.

# 11. IMAGES

## IQ-CONTROL BOX REAR VIEW

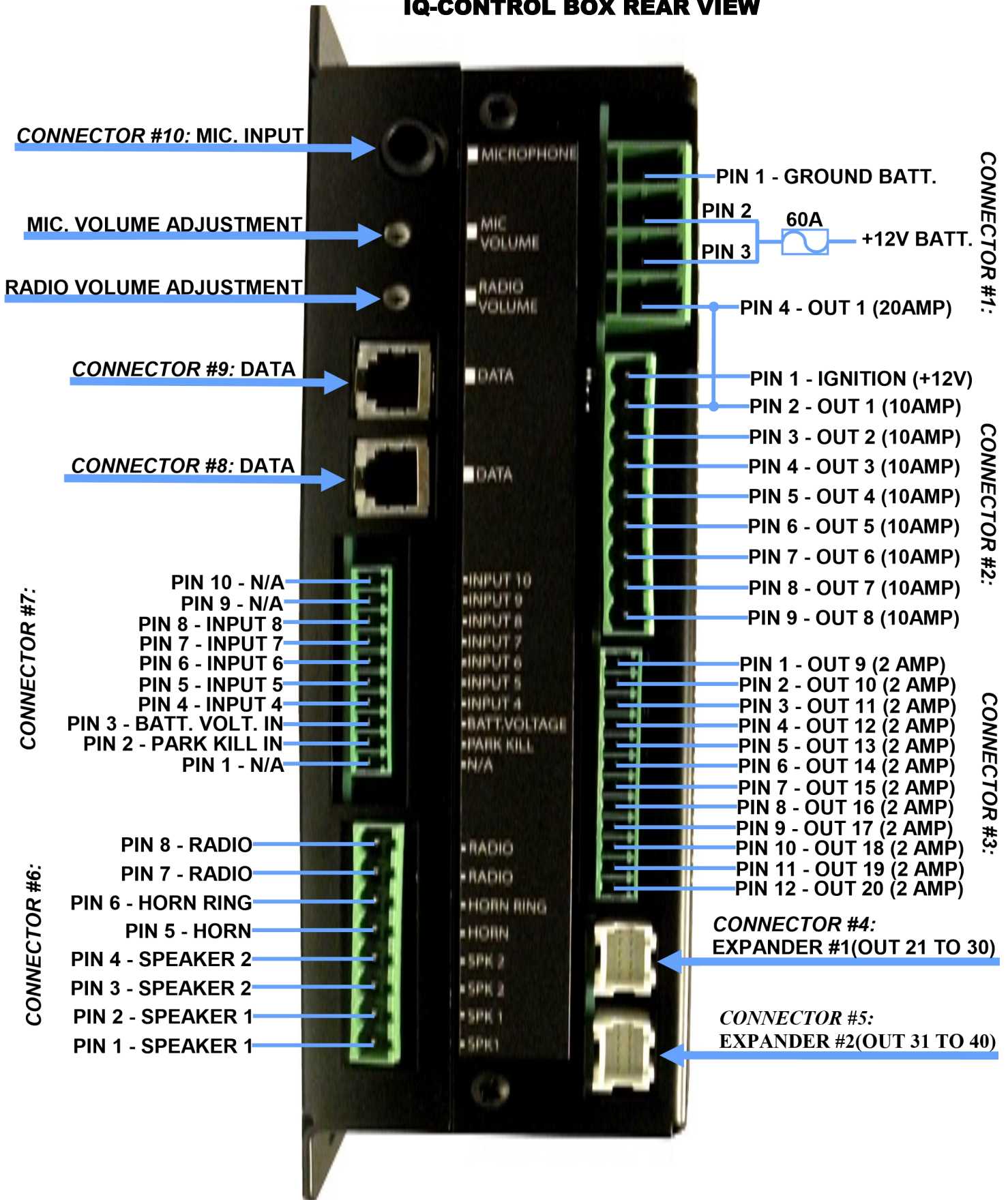
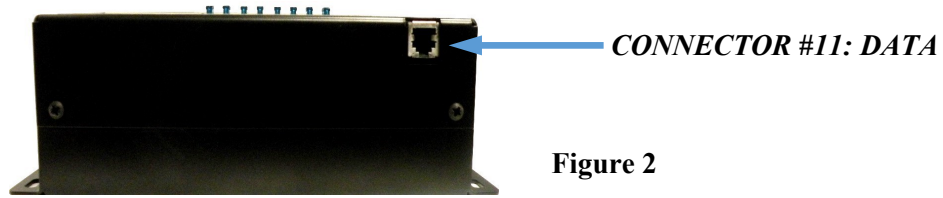

Figure 1: Input / Output Layout

## **IQ-CONTROL BOX FRONT VIEW**



**Figure 2**

## **IQ-CONTROL BOX TOP VIEW**

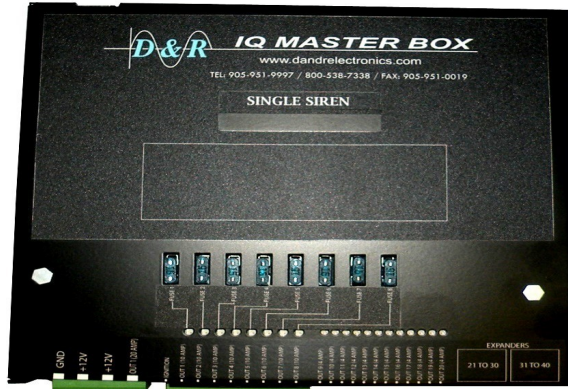

**Figure 3: IQ-Control Box Output LED Indicators And Output fuses**

## **12. TOUCHPAD FILE UPLOAD ERROR CODES**

#	Error Name	Error Description	LCD Display
1	FIELD_COUNT	TPP file fields counts is wrong, file content is wrong	Error 1
2	INVALID_VERSION	TPP file version is wrong	Error 2
3	WRONG_TOUCHPAD	TPP file is defined wrong TouchPad type	Invalid TP
4	UNEXPECTED_RECORD	TPP file unexpected record exist, file content is wrong	Error 4
5	LIGHTBAR_COMM	TouchPad has no communication with LightBar	L Comm Err
6	RELAY_COMM	TouchPad has no communication with Relay Board	R Box Err
7	FILE_ERR	TPP file read / write error	Error 7
8	USB_ERR	Detect USB thumb drive error	Init Failed! Remove Drive
9	MEMORY_ERR	Read USB thumb error	Memory Fault
10	FILE_NOT_FOUND	There is no TPP file in USB thumb	No TP Files
11	RA_MESG_ERR	Road Alert Message Board communication error	Error 11
15	FILE_OK	TPP file upload successful. No error	Done!

## WARRANTY

D & R Electronics warrants its new products to be free from defects in material and workmanship, under normal use and service for a period of three years on parts replacement.

This warranty applies only to original purchasers acquiring the product directly from D&R Electronics, or its authorized dealers. Warranty will not be recognized without proof of purchase or bill of sale.

This warranty is not transferable.

The warranty begins on the date of delivery to the first user/purchaser.

This warranty shall not apply to products which must be repaired due to normal wear and tear, negligence, improper installation, abuse, misuse, or which have been altered or modified at a facility other than D & R Electronics, or its authorized depot centers.

Units proved to be defective within the warranty period, based on an examination by D&R Electronics, will be replaced or repaired at D & R Electronics' option. This warranty does not cover travel expenses or labor charges for removal or installation.

Lamps, flash tubes, batteries or other items considered consumables are not covered under warranty.

This warranty is in lieu of all other express warranties. D&R Electronics makes no warranties, expressed or implied, other than the express warranties contained herein.

## PRODUCT RETURN POLICY

In order to provide you with faster service, product returns for repair or replacement, must have a **Return Goods Authorization Number (RGA number)**. Please contact our company to obtain a RGA number before you return the product to D & R ELECTRONICS. Write the RGA number clearly on the exterior of the package. Be sure you use sufficient packing materials to avoid damage to the product being returned while in transit.

D & R ELECTRONICS assumes no responsibility or liability for expenses incurred for the removal and/or the installation of products requiring service and/or repair. Repairing or replacing product is at the discretion of D & R ELECTRONICS.

## D&R ELECTRONICS Co. LTD.

### CANADA

8820 George Bolton Pkwy.

Bolton, Ontario L7E 2Y4

Tel: (905) 951-9997

Fax: (905) 951-0019

### USA

2299 Kenmore Avenue

Building 3, Doors 11-14

Buffalo, New York 14207

Toll Free: 1-800-538-7338

[www.dandrelectronics.com](http://www.dandrelectronics.com)