

2013 FORD INTERCEPTOR FULL SIZE CABINET SUBFRAME 933-0099A
INSTALLATION

NOTE: IMAGES SHOWN ARE OF THE REGULAR INTERCEPTOR SUBFRAME. FULL SIZE CABINET SUBFRAME IS TO BE INSTALLED THE SAME WAY.

VIEW: BEFORE INSTALL. NOTE LEAVE ANY FOAM AS IS FOR SUPPORT.

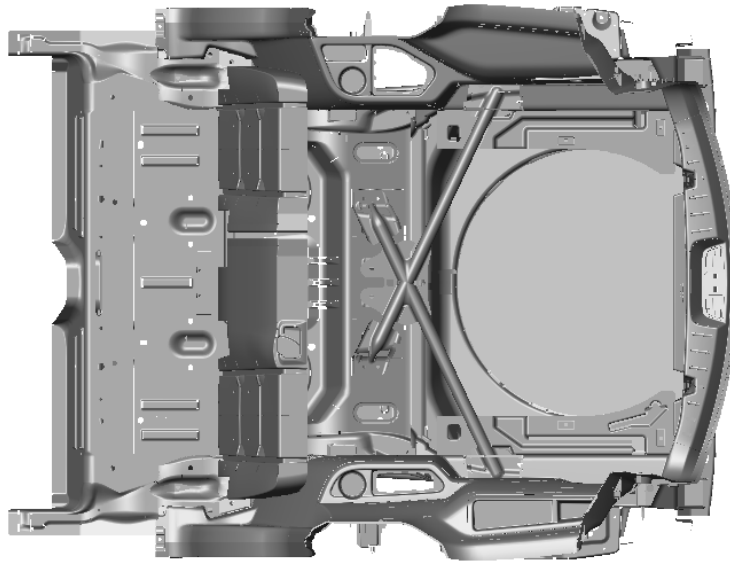

VIEW: REMOVE PLASTIC COVER & THEN PLACE SUBFRAME.

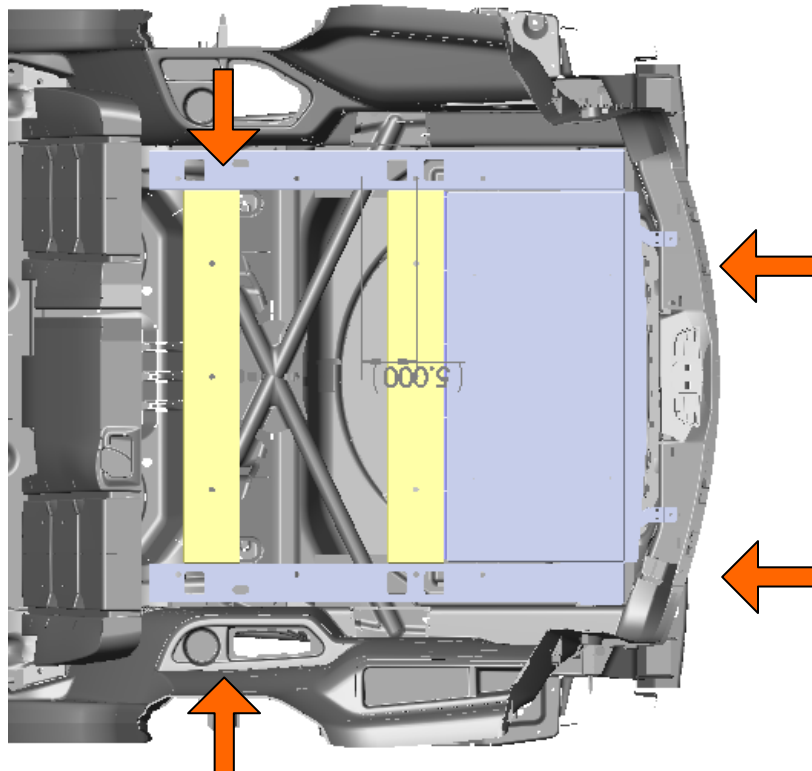

Insert Hardware to secure sub frame where marked above.

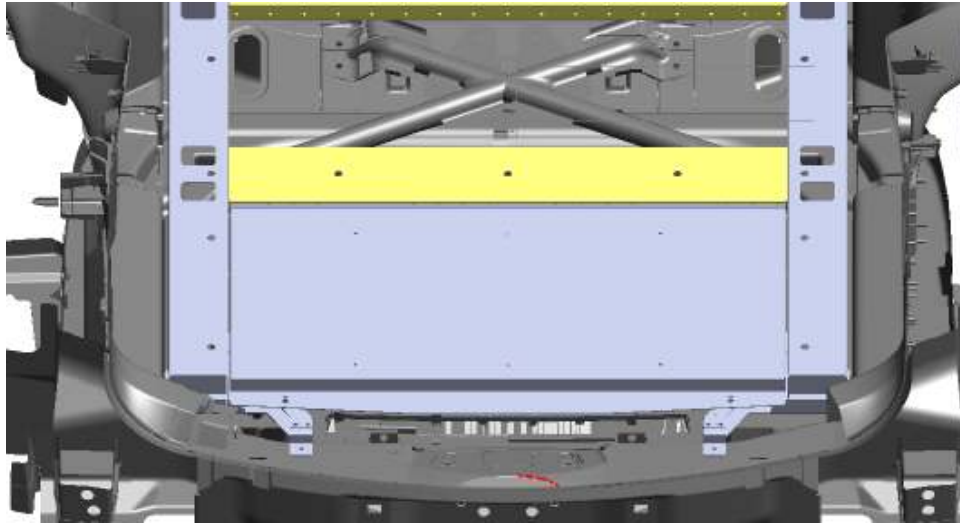

VIEW: FASTEN SUBFRAME & REPLACE PLASTIC COVER

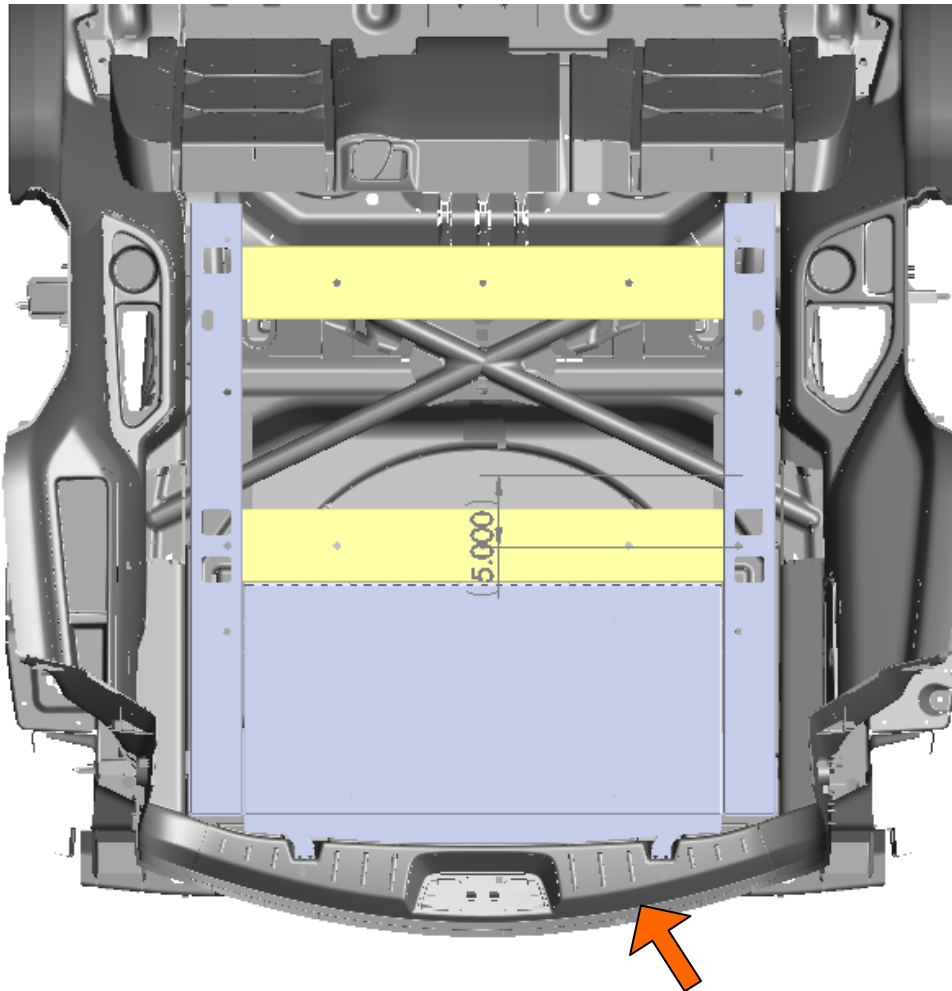

WARRANTY

D & R Electronics warrants its new products to be free from defects in material and workmanship, under normal use and service for a period of one year on parts replacement and one year on labor. This warranty applies only to original purchasers acquiring the product directly from D&R Electronics, or its authorized dealers. Warranty will not be recognized without proof of purchase or bill of sale. This warranty is not transferable. The warranty begins on the date of delivery to the first user/purchaser. This warranty shall not apply to products which must be repaired due to normal wear and tear, negligence, improper installation, abuse, misuse, or which have been altered or modified at a facility other than D & R Electronics, or its authorized depot centers. Units proved to be defective within the warranty period, based on an examination by D&R Electronics, will be replaced or repaired at D & R Electronics' option. This warranty does not cover travel expenses or labor charges for removal or installation. Lamps, flash tubes, batteries or other items considered consumables are not covered under warranty. This warranty is in lieu of all other express warranties. D&R Electronics makes no warranties, expressed or implied, other than the express warranties contained herein.

PRODUCT RETURN POLICY

In order to provide you with faster service, product returns for repair or replacement, must have a **Return Goods Authorization Number (RGA number)**. Please contact our company to obtain a RGA number before you return the product to D & R ELECTRONICS. Write the RGA number clearly on the package. Be sure you use sufficient packing materials to avoid damage to the product being returned while in transit.

D & R ELECTRONICS assumes no responsibility or liability for expenses incurred for the removal and/or the installation of products requiring service and/or repair.

Repairing or replacing product is at the discretion of D & R ELECTRONICS.

D&R ELECTRONICS Co. LTD.

CANADA

8820 George Bolton Pkwy.
Bolton, Ontario L7E 2Y4

Tel.: (905)951-9997

Fax: (905)951-0019

USA

40 Sonwil Drive
Cheektowaga, NY, 14225

Toll Free 1-800-538-7338

www.dandrelectronics.com