

# BCN24 LED BEACON

## S P E C S

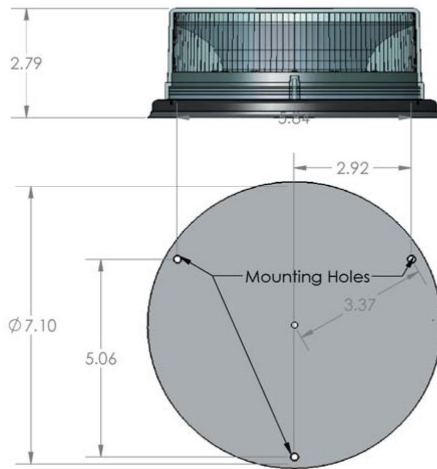

Shown with 08.0308 Magnet

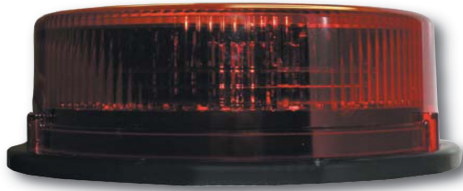

Optional:  
215-0183 for Magnet Mount  
only



- Polycarbonate base and lenses with UV protection.
- Amperage draw: Average—1.8 Amp, Peak—3.6 Amp
- Operating Voltage: 9.5V-24V
- Dimmer Function through wire connection
- Comes with 3ft straight cable for permanent mount
- Optional Lighter Plug with dual switch (ON/OFF and Momentary) and with 15ft straight cable—Part# 215-0183
- Mounting Options; magnet, mirror mount, truck rack,
- 25 Flash Patterns with 2 Simulated Rotating Patterns
- Available Lens Colours: Amber, Blue, Clear, Red
- Available Led Colours : Amber,Blue,Clear,Green,Red
- Weight is less then 3lbs
- \*\*\*\*\* SAE J845 Class 1 Certified in Amber \*\*\*\*\*
- For Magnet mount order magnet mounting kit#: 499-0003 Magnetic Mount Version Includes :
  - 1) One 3" round 90 lb pull magnet
  - 2) One 15 Ft cable with dual switch power plug

Canada; 8820 George Bolton Pkwy. Bolton, ON L7E 2Y4 | TF: 800-538-7338  
USA: 2299 Kenmore Ave. Building 3, Doors 11-14, Buffalo, NY 14207  
ISO 9001:2015 REGISTERED COMPANY