

Angled LED Area/Scene/Work Lights



Extremely Robust Lights that are ideally suited for illuminating areas on or around Utility/Municipal trucks or the perimeter of Emergency Vehicles, Mobile Command Units, RV'S, as well as the Exterior and/or Interior of Trailers.

- Lights include Stainless Steel mounting hardware, gasket and 14" insulated wire
- The face of these versatile Surface Mount LED lights slants downward at a 60 deg. angle with a Beam Spread angle of 90 deg. providing intense cool white light where required
- IP68 rated to resist water and to withstand dust, dirt and sand found in harsh environments
- Operating Temperature: -40-+50 C (-40-+122F) / Operating Voltage Range: 10 – 30 VDC
- Maintenance-Free LEDs have a lifespan of 80,000 hours
- 5 Year Warranty
- **Model Number K0946181 / K0946182:** (18) Eighteen 1W LEDs / 6500K Cool White / Raw Lumens 1800 Effective Lumens 1600 / 1.4A Max at 12V / 1.8"H x 2"D x 9"L / Weight 1.15 lbs
- **Model Number K0946301 / K0946302:** (30) Thirty 1W LEDs / 6500K Cool White / Raw Lumens 3000 / Effective Lumens 2780 / 2.67A Max at 12V / 1.8"H x 2"D x 12"L / Weight: 1.5 lbs
- **Model Number K0946421 / K0946422:** (42) Forty two 1W LEDs / 6500K Cool White / Raw Lumens 4200 / Effective Lumens 3612 / 3.5A Max at 12V / 1.8"H x 2"D x 15.4"L / Weight:
- White or Black cast aluminum housing with polycarbonate lens ensures years of trouble-free operation
- **Model Numbers: 9" Light K0946181 White Housing / K0946182 Black Housing**
12" Light K0946301 White Housing / K0946302 Black Housing
15" Light K0946421 White Housing / K0946422 Black Housing

>Special Order Colours that are available in the 9" model: K0946183 Chrome
(MINIMUM ORDER QUANTITIES are REQUIRED) K0946184 Red RAL3000
K0946185 Yellow RAL1016

K0946181/ K0946182

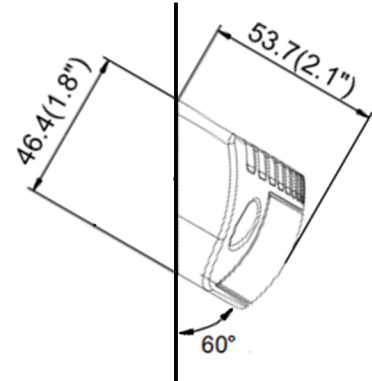
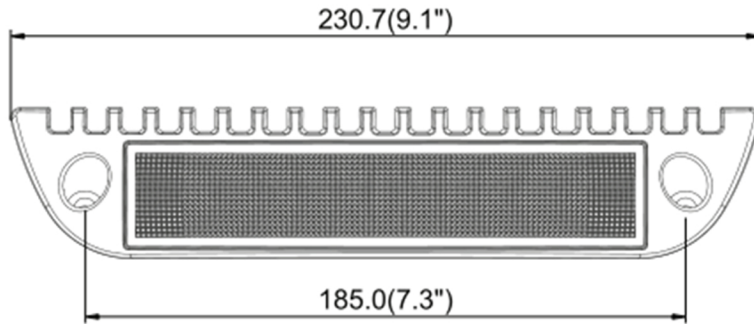

K0946421/ K0946422

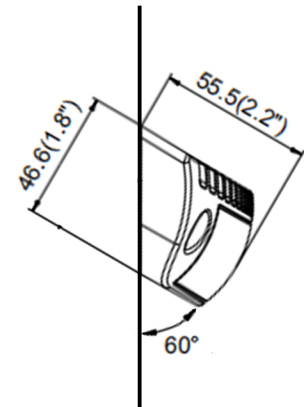
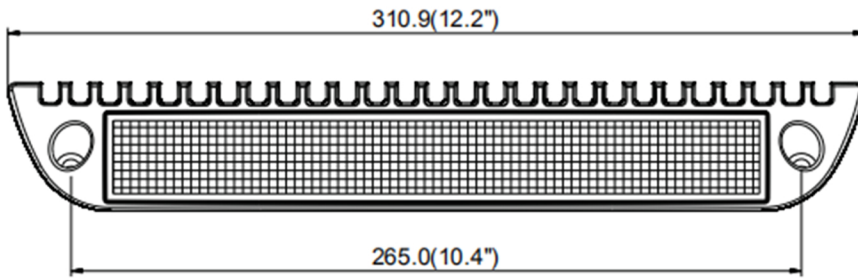

K0946301/ K0946302

