

REV.	DESCRIPTION	BY	DATE	APPROVED

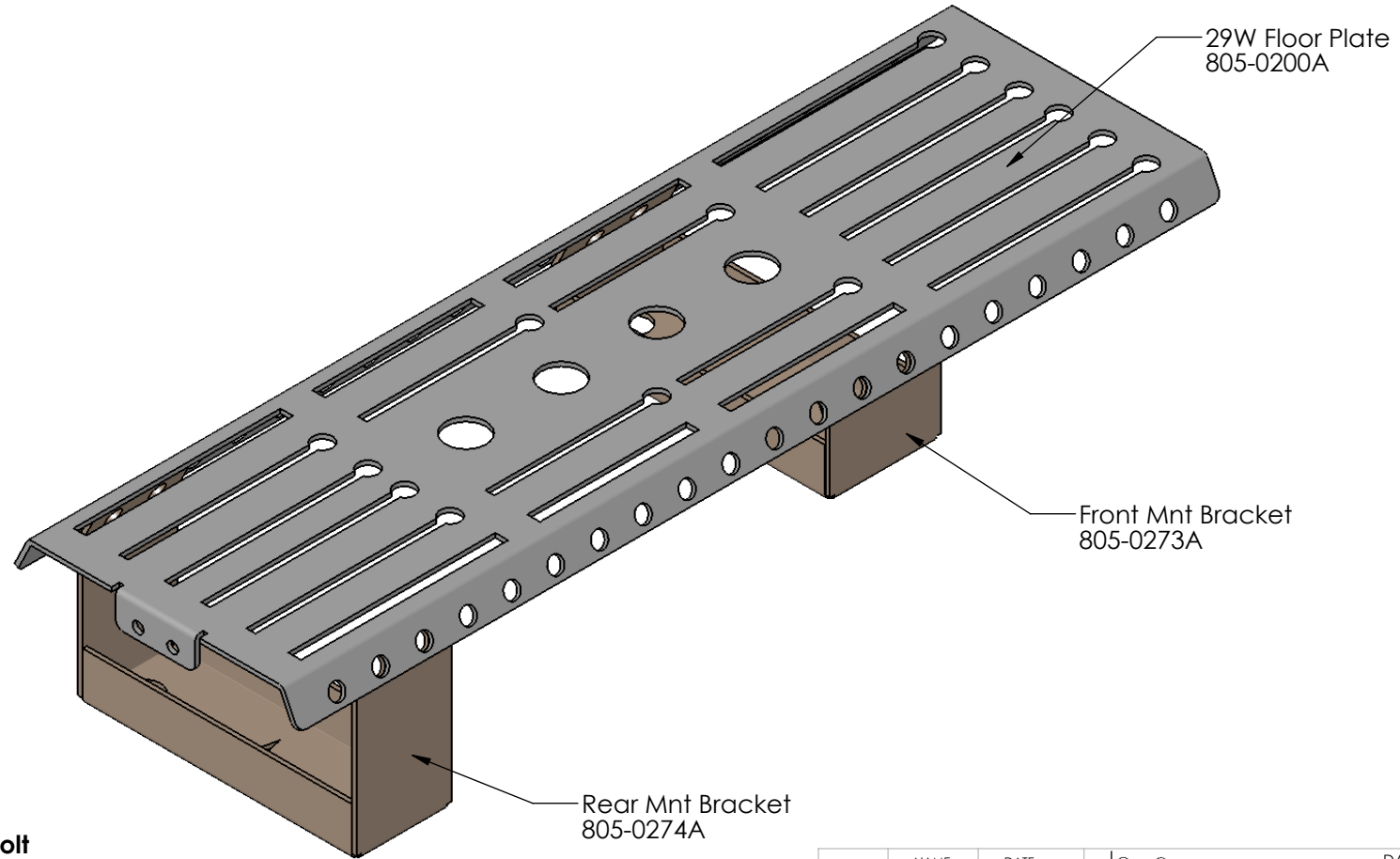

Install Hardware

- 8x 3/8-16 X 1" Hex Bolt**
- 8x 3/8" Flat Washer**
- 8x 3/8" Lock Washer**

NOTES

- DO NOT BAG FLOOR PLATE**
- BAG BRACKETS AND HARDWARE IN INDIVIDUAL BAGS**
- INSTALL BRACKETS WITH ARROW POINTING TOWARDS THE FRONT OF THE VEHICLE**

	NAME	DATE	ELECTRONICS CO. <small>2015 F150 Floor Plate Kit</small>	DANDR-ANSI-A REV2 APRIL 1, 2009	SIZE A
DRAWN	JV	30APR15		Path: \\server-file\data\M\MECH_DESIGN\2015 F150 Floor Plate Kit\ File: 905-0135A Date: Thursday, April 30, 2015 11:52:27 AM	
CHECKED	AD	30APR15	DESCRIPTION: 2015 F150 Floor Plate Kit		
THE INFORMATION CONTAINED WITHIN THIS DRAWING IS PROPRIETARY AND CONFIDENTIAL. AND IS THE SOLE PROPERTY OF DandR ELECTRONICS CO. LTD. IT MAY NOT BE REPRODUCED AT WHOLE OR IN PART WITHOUT THE WRITTEN PERMISSION OF DandR ELECTRONICS CO. LTD.			MFG. NO. 905-0135A	CATALOG. NO. XXX	
FINISH Midnight Black Wrinkle			USED ON: 9XX-XXXX		SHEET 1 OF 1
			MATERIAL 10 ga CRS	REV. 0	