



**ELECTRONICS CO. LTD.**  
EMERGENCY VEHICLE SOUND, LIGHTING & EQUIPMENT

# Chevy Suburban K9 Kennel

P/N 934-0728A

## INSTALLATION MANUAL

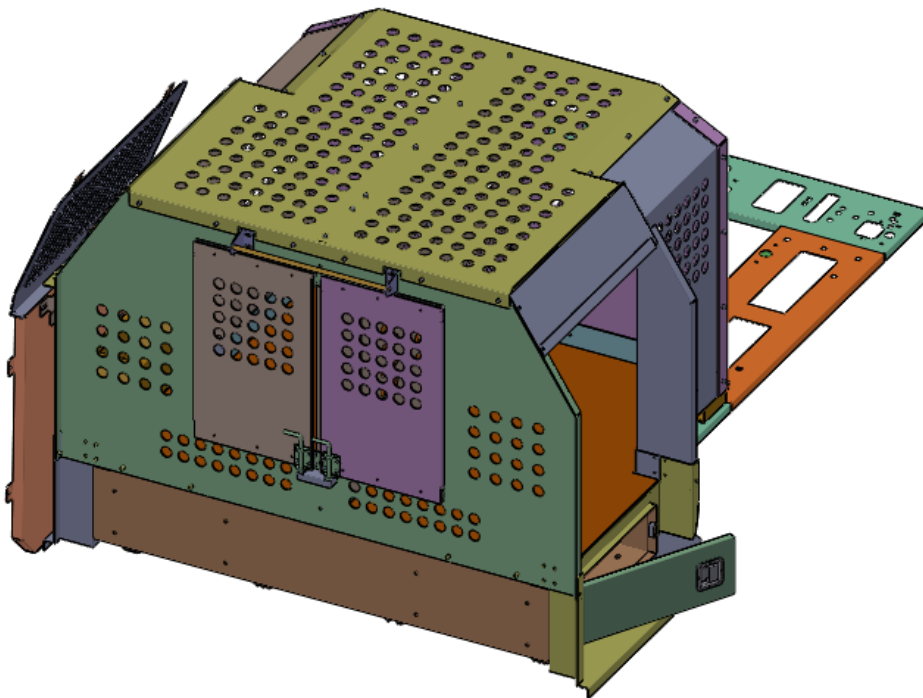

### CONTENTS

Unpacking	2
Installation	3
Warranty	9
Return Policy	9

# UNPACKING

Before beginning any installation, unpack the equipment received. After unpacking, examine **ALL** components received for any damage that may have occurred while in transit. If any damage has occurred, file a claim **IMMEDIATELY** with the courier stating the extent of damage. Check **ALL** envelopes, packing slips, shipping labels and tags before removing or destroying them. To ensure your satisfaction, open all cartons and report any shortages **within 48 hours of receipt.**

HARDWARE PARTS LIST

Quantity	Description
90	1/4-20 x 3/4" Hex Head Screws
4	1/4-20 x 5/8" Hex Head Screws
7	1/4-20 x 3/4" Flat Head Screws
94	1/4-20 Lock Washer
94	1/4-20 Flat Washer
14	1/4-20 Nyloc Nuts
16	#10-32 x 5/8" RD Head Screws
16	#10-32 Flat Washer
16	#10-32 Lock Washer
20	#10 x 3/4" Self Tapping Screw
4	3/8-16 x 1" Hex Bolt

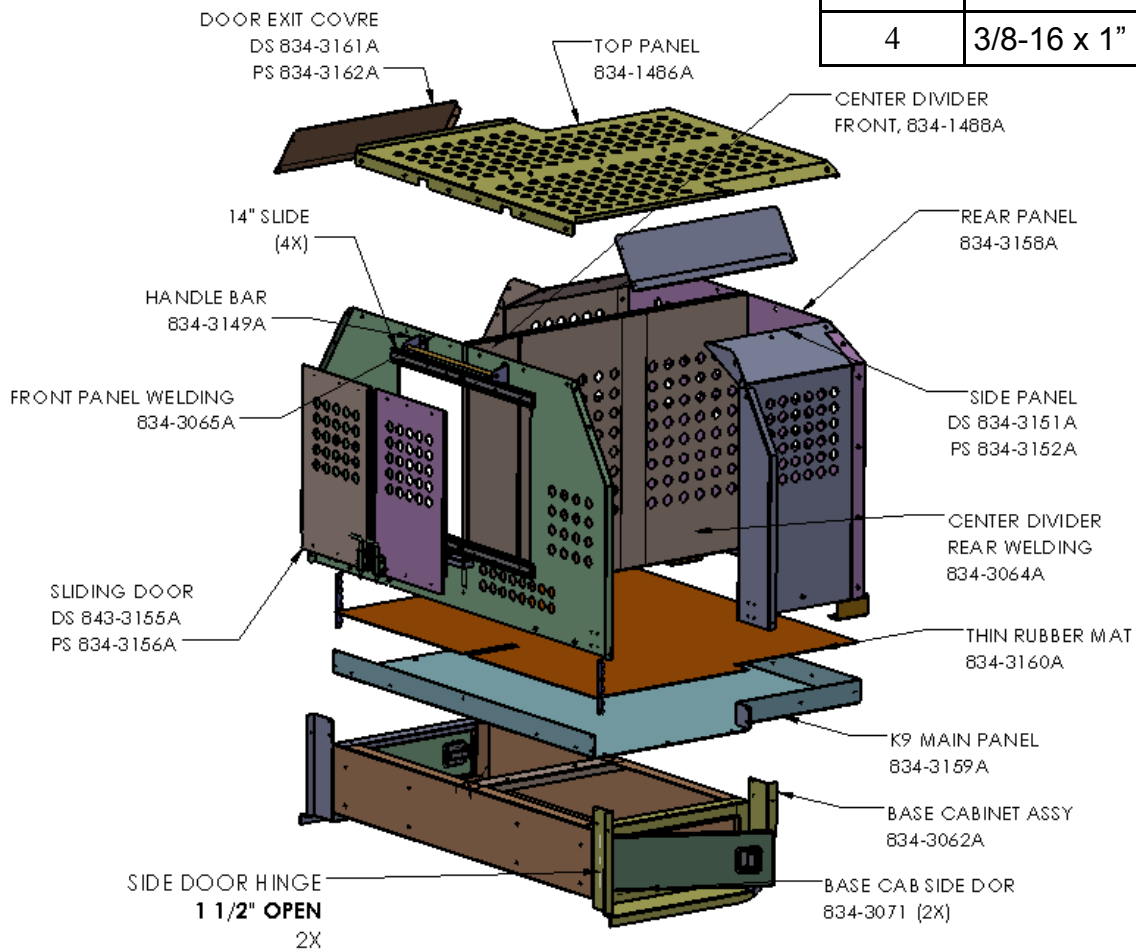

## VEHICLE PREPARATION

Remove the 2 rear seats and set aside. Some Plastic floor panels may require removal as well. The removed seat bolts will be used to fasten the sub-frame to the floor. Remove Driver and Passenger Side Rear door panels and set aside.

Contact D&R if you are unsure how to remove the Seats or Door Panels.

## INSTALLATION OF K9 UNIT

### Step 1

#### Sub-frames into Vehicle

Place the cabinet subframe and the K9 sub-frame over the seat mount holes and studs. Center the sub-frame & secure using all factory seat bolts and nuts.

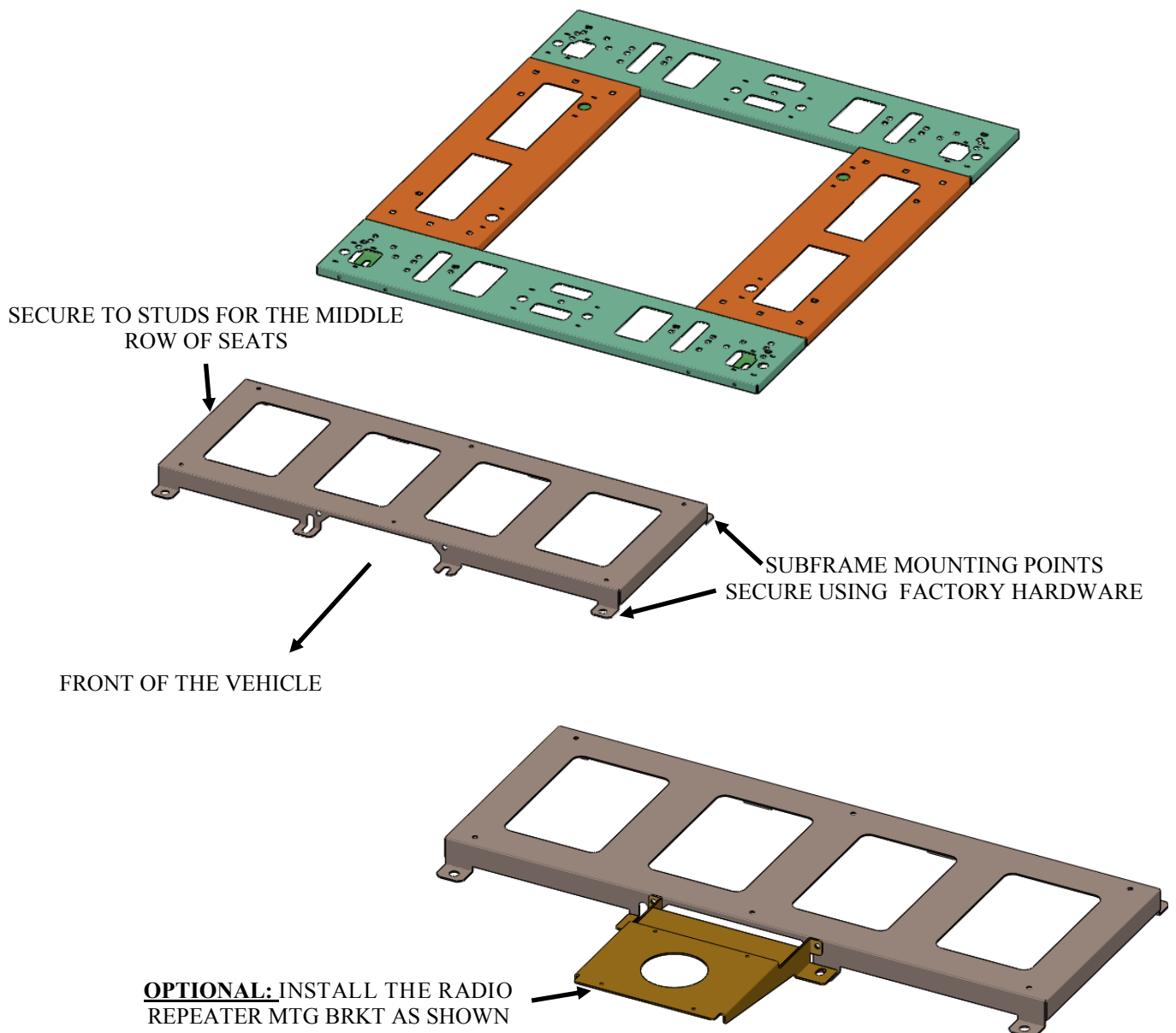

## Step 2

### Bottom Cabinet and Support Brackets to Subframe

Place and secure bottom cabinet assembly on the subframe in the front and the support brackets on the subframe in the back.

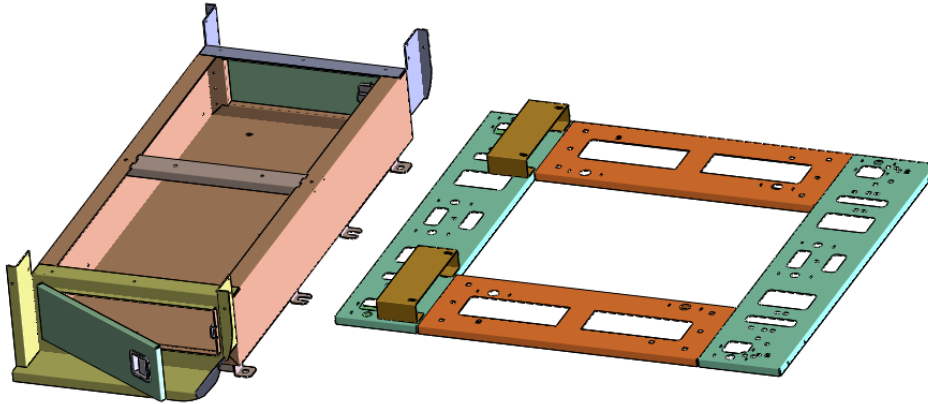

## Step 3

### K9 Main Base Panel

Place the base panel on the bottom cabinet assembly and the support brackets and secure using 1/4-20 x 3/4" Flat head screws.

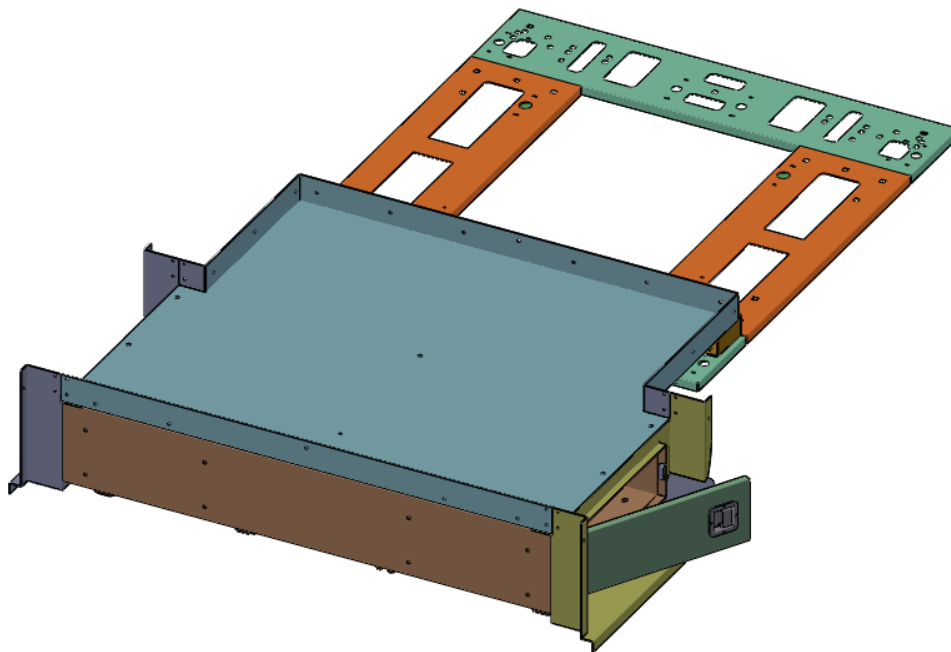

## Step 4

### Rear and Front Panel Assembly to Base Panel

Install and secure the rear and front panel assembly to the base panel using 1/4-20 x 3/4" Hex bolt and washers. Front Panel assembly also requires #10 hardware and include the sliding doors and handle bar. Place rubber mat on the base panel.

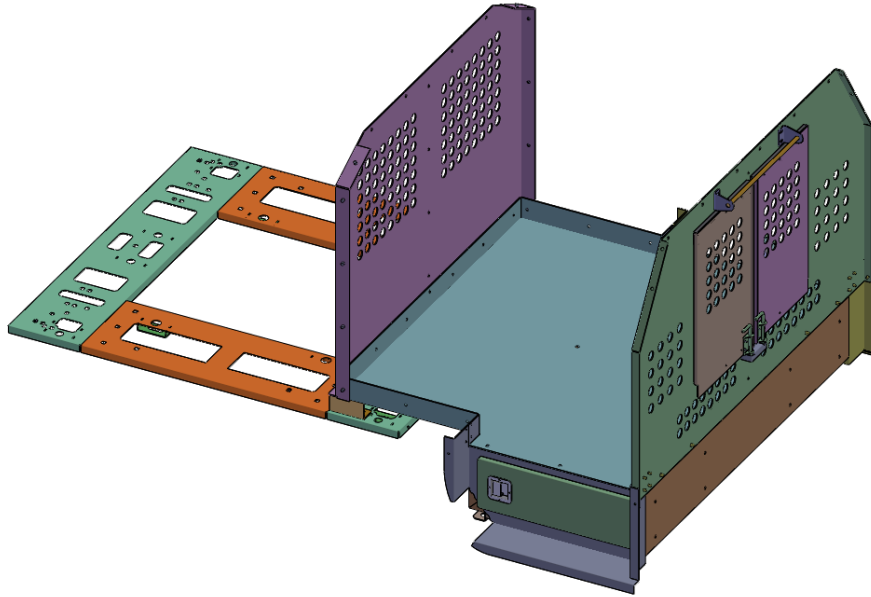

## Step 4

### Centre Dividers

Place the two divider panels between the rear panel and front panel. Secure together and to the rear and front panel using 1/4-20 x 3/4" Hex bolts and washers.

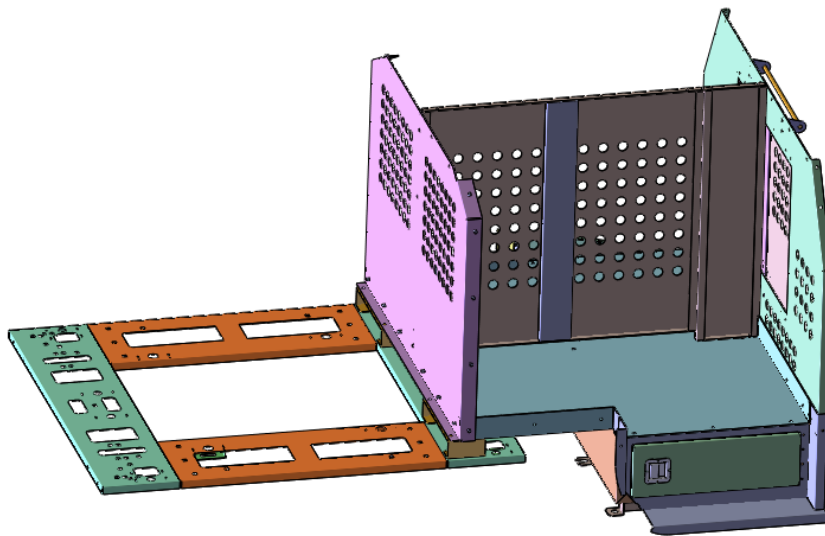

## Step 5

### Side Panels to Back Panel

Place Install side panels and secure to base panel and rear panel using 1/4-20 and #10 hardware.

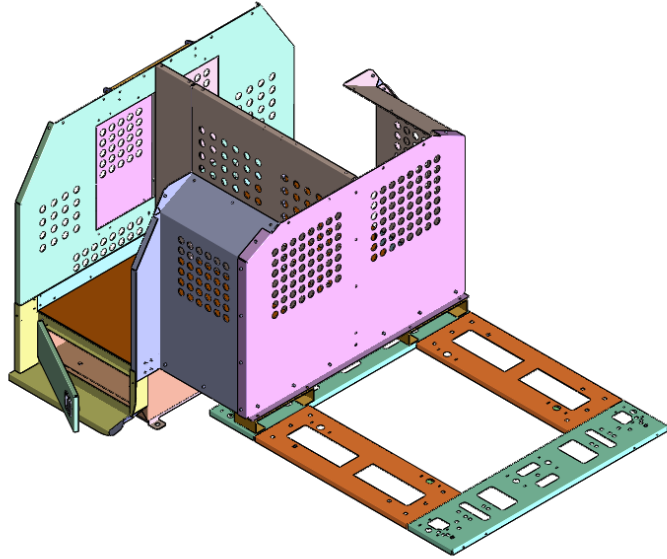

## Step 6

### Roof Panel

Place the roof panel over the components and secure to the front, rear, side and divider panels using 1/4-20 hardware.

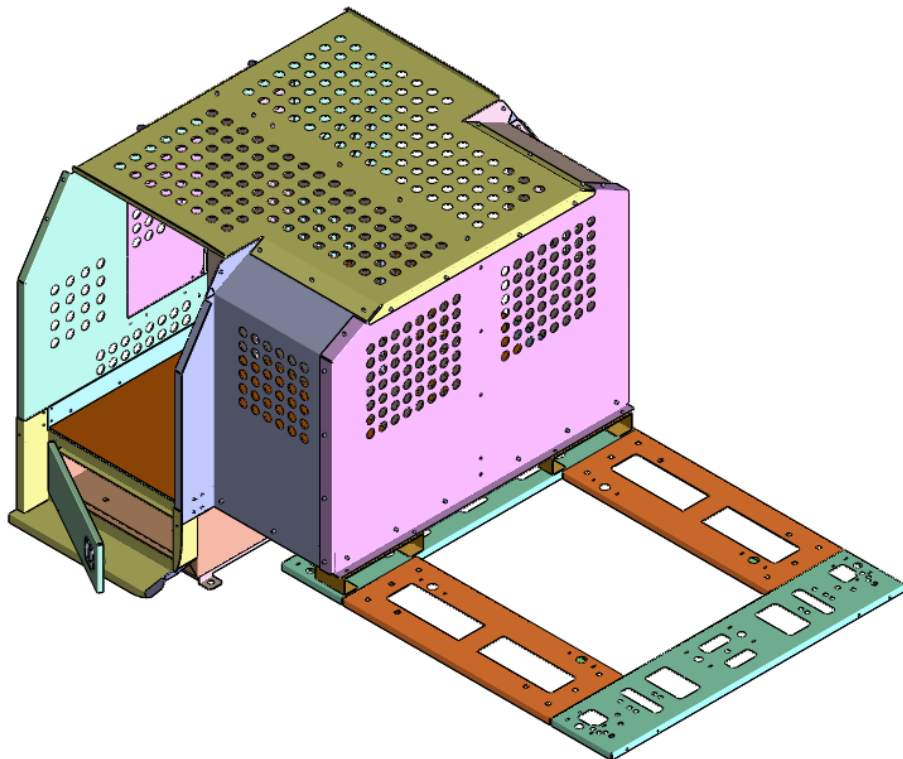

## Step 7

### Door Exit Panels

Install the DS and PS door exit panels and secure to the side and the front panels using 1/4-20 hardware.

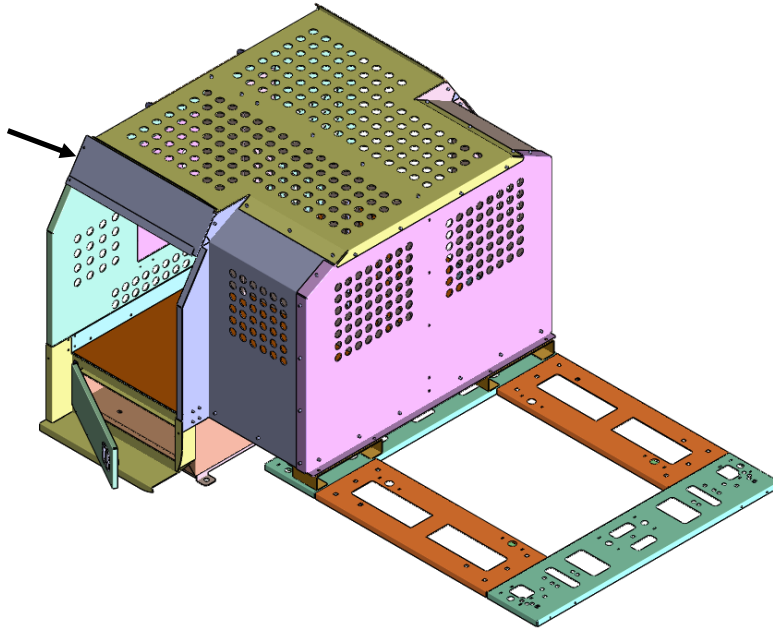

## Step 8

### OPTIONAL: Battery Box and Electronics Box

Install the battery and electronics box to the base of the K9 unit.

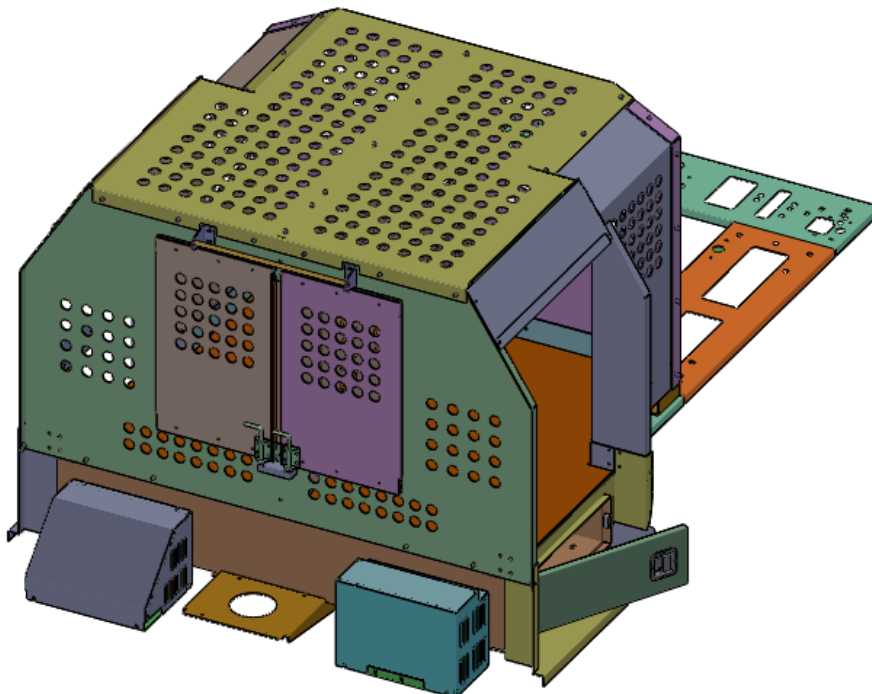



## Step 9

### Door Panel and Window Guard

Install the door panel and window guard on the PS door as shown below using 10x #10 x 3/4" self tapping screws. Secure the window guard to the top brackets using 2x 1/4-20 x 5/8" Screws and washers and to the door panel using 3x 1/4-20 Nylock nuts and washers. Repeat for DS

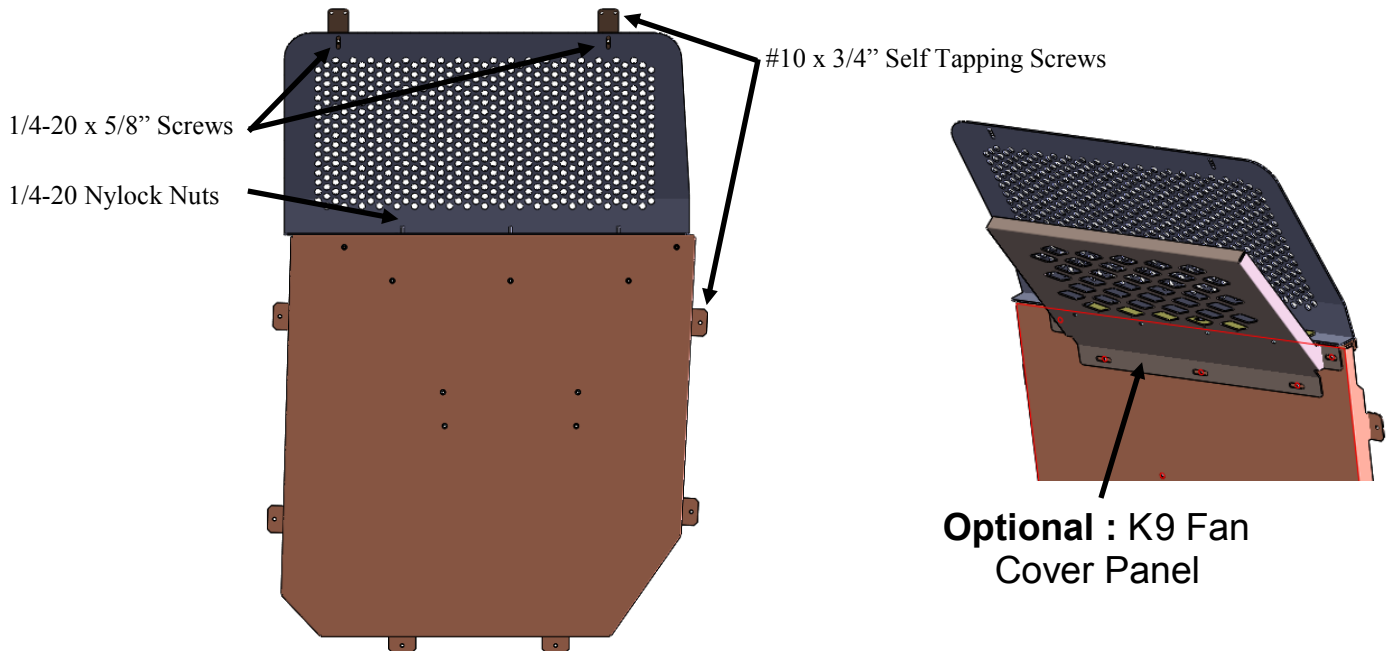

## Step 10

### Bowl Holding Brkt

Install the bowl holding brkt on the door panel and secure using 4x 1/4-20 x 3/4" Hex bolts and washers. Then, mount the water bowl in place.

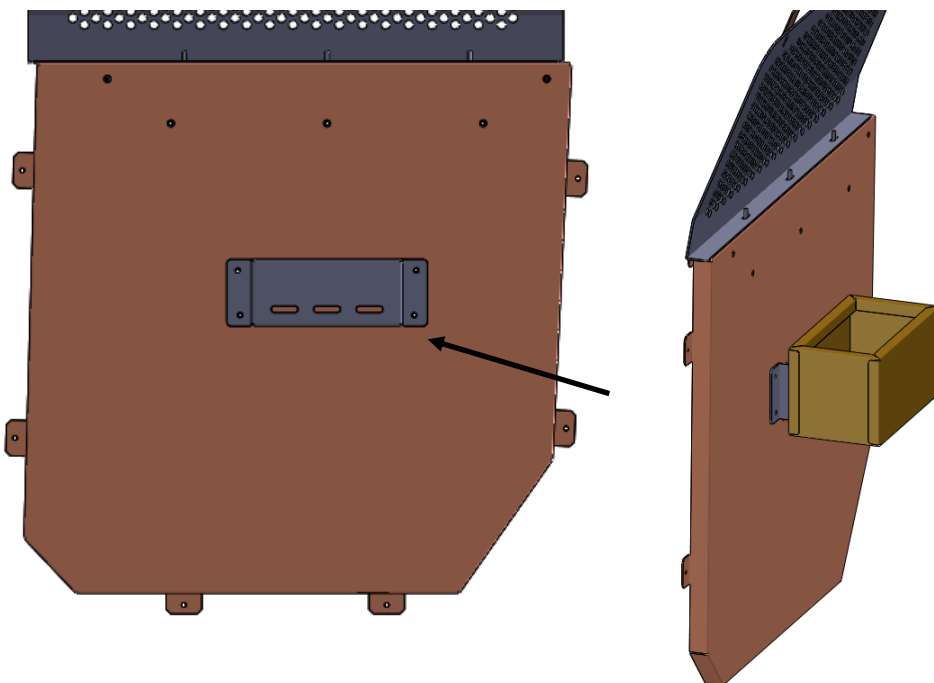



## WARRANTY

D & R Electronics warrants its new products to be free from defects in material and workmanship, under normal use and service for a period of one year on parts replacement and one year on labor. This warranty applies only to original purchasers acquiring the product directly from D&R Electronics, or its authorized dealers. Warranty will not be recognized without proof of purchase or bill of sale. This warranty is not transferable. The warranty begins on the date of delivery to the first user/purchaser. This warranty shall not apply to products which must be repaired due to normal wear and tear, negligence, improper installation, abuse, misuse, or which have been altered or modified at a facility other than D & R Electronics, or its authorized depot centers. Units proved to be defective within the warranty period, based on an examination by D&R Electronics, will be replaced or repaired at D & R Electronics' option. This warranty does not cover travel expenses or labor charges for removal or installation. Lamps, flash tubes, batteries or other items considered consumables are not covered under warranty. This warranty is in lieu of all other express warranties. D&R Electronics makes no warranties, expressed or implied, other than the express warranties contained herein.

## PRODUCT RETURN POLICY

In order to provide you with faster service, product returns for repair or replacement, must have a **Return Goods Authorization Number (RGA number)**. Please contact our company to obtain a RGA number before you return the product to D & R ELECTRONICS. Write the RGA number clearly on the package. Be sure you use sufficient packing materials to avoid damage to the product being returned while in transit. D & R ELECTRONICS assumes no responsibility or liability for expenses incurred for the removal and/or the installation of products requiring service and/or repair.

**Repairing or replacing product is at the discretion of D & R ELECTRONICS.**

### D&R ELECTRONICS Co. LTD.

#### CANADA

8820 George Bolton Pkwy.  
Bolton, Ontario L7E 2Y4

Tel.: (905)951-9997  
Fax: (905)951-0019

#### USA

2321 Kenmore Ave  
Buffalo, NY, 14207

Toll Free 1-800-538-7338

[www.dandrelectronics.com](http://www.dandrelectronics.com)