

WARRANTY

D & R Electronics warrants its new products to be free from defects in material and workmanship, under normal use and service for a period of one year on parts replacement and one year on labor. This warranty applies only to original purchasers acquiring the product directly from D&R Electronics, or its authorized dealers. Warranty will not be recognized without proof of purchase or bill of sale. This warranty is not transferable. The warranty begins on the date of delivery to the first user/purchaser. This warranty shall not apply to products which must be repaired due to normal wear and tear, negligence, improper installation, abuse, misuse, or which have been altered or modified at a facility other than D & R Electronics, or its authorized depot centers. Units proved to be defective within the warranty period, based on an examination by D&R Electronics, will be replaced or repaired at D & R Electronics' option. This warranty does not cover travel expenses or labor charges for removal or installation. Lamps, flash tubes, batteries or other items considered consumables are not covered under warranty. This warranty is in lieu of all other express warranties. D&R Electronics makes no warranties, expressed or implied, other than the express warranties contained herein.

PRODUCT RETURN POLICY

In order to provide you with faster service, product returns for repair or replacement, must have a **Return Goods Authorization Number (RGA number)**. Please contact our company to obtain a RGA number before you return the product to D & R ELECTRONICS. Write the RGA number clearly on the package. Be sure you use sufficient packing materials to avoid damage to the product being returned while in transit. D & R ELECTRONICS assumes no responsibility or liability for expenses incurred for the removal and/or the installation of products requiring service and/or repair. **Repairing or replacing product is at the discretion of D & R ELECTRONICS.**

D&R ELECTRONICS Co. LTD.
 CANADA
 8820 George Bolton Pkwy. Bolton, ON,
 L7E 2Y4
 Tel.: (905)951-9997 Fax: (905)951-0019
 Toll Free 1-800-538-7338
 www.dandrelectronics.com

USA
 2321 Kenmore Ave.
 Buffalo, NY 14207



2012 Ford Interceptor Explorer K9 Kennel
 For Single Dog
 P/N 934-0533A / B

INSTALLATION MANUAL

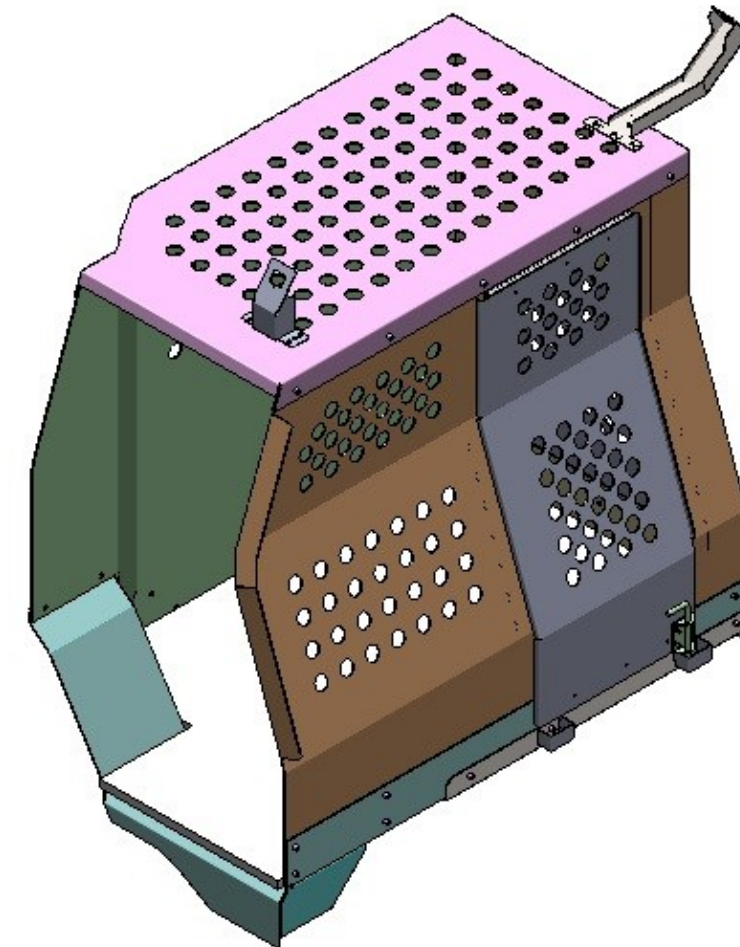

CONTENTS

Unpacking	—	2
Installation	—	3
Warranty	—	12
Return Policy	—	12

UNPACKING

Before beginning any installation, unpack the equipment received. After unpacking, examine **ALL** components received for any damage that may have occurred while in transit. If any damage has occurred, file a claim **IMMEDIATELY** with the courier stating the extent of damage. Check **ALL** envelopes, packing slips, shipping labels and tags before removing or destroying them.

To ensure your satisfaction, open all cartons and report any shortages **within 48 hours of receipt.**

HARDWARE PARTS LIST

Quantity	Description
12	SCREW, 10-32 x 1/2 COUNTER SUNK
12	NUT, 10-32, NYLOC, ZINC
12	NUT, 10-32, WASHER
61	WASHER, 1/4 FLAT, SAE, ZINC
45	LOCK WASHER, 1/4 SAE, ZINC
53	BOLT, 1/4-20 x 3/4" HEX, ZN
8	NUT, 1/4-20, NYLOC, ZINC
2	BOLT, 1/4-20 X 5/8" HEX, ZINC
2	WASHER, 1/4 FLAT, SAE, ZINC
2	LOCK WASHER, 1/4 SAE,ZINC
2	14" SLIDES
3	BUTT HINGE

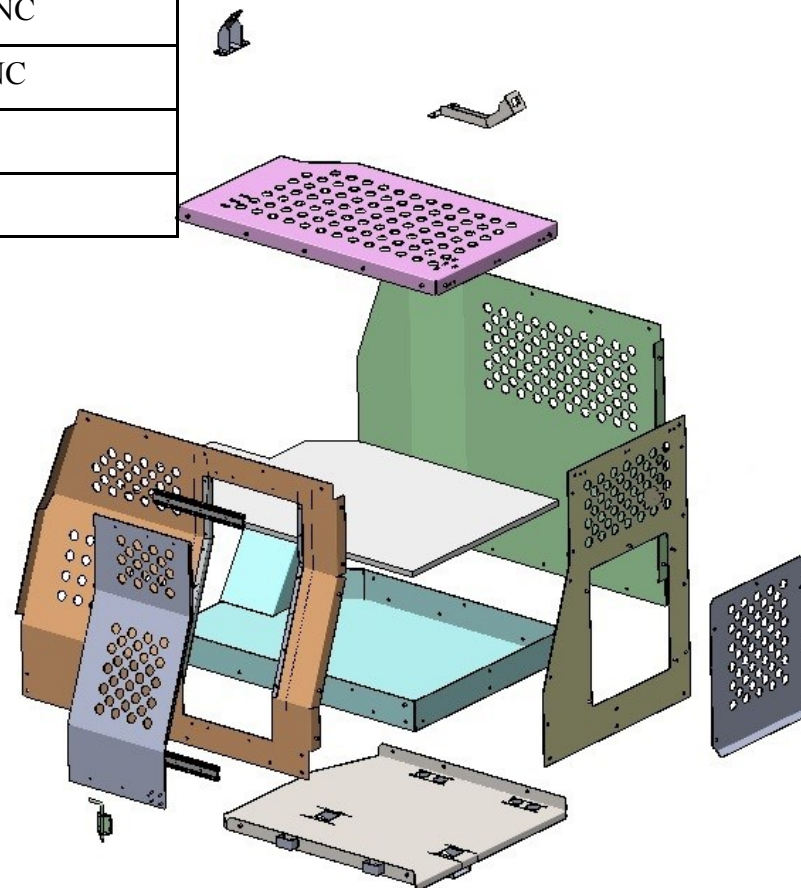

Step 17

Window Guard Brackets

Fasten the WG Brackets to the WG using (2x) 1/4-20 X 5/8 Hex Bolts, Lock Washers and Washers and then rivet onto PS Door frame.

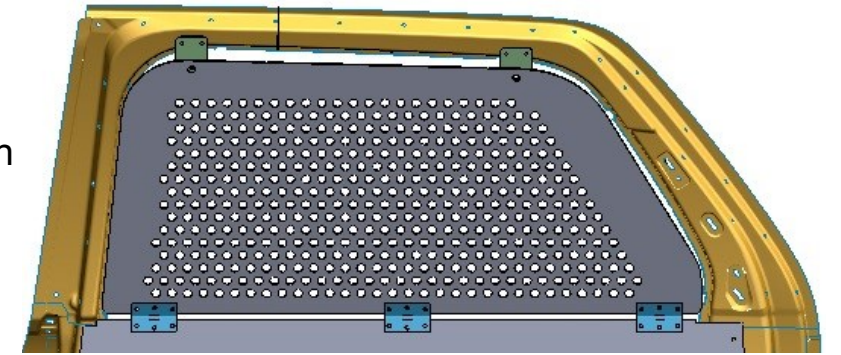

Step 18 (OPTIONAL)

K9 Cooling Fan to Window Guard

Place supplied cooling fan over the WG and Drill mounting holes. Secure using hardware.

Step 19 (OPTIONAL)

Spring gas shock

Place spring gas shock as shown and install.

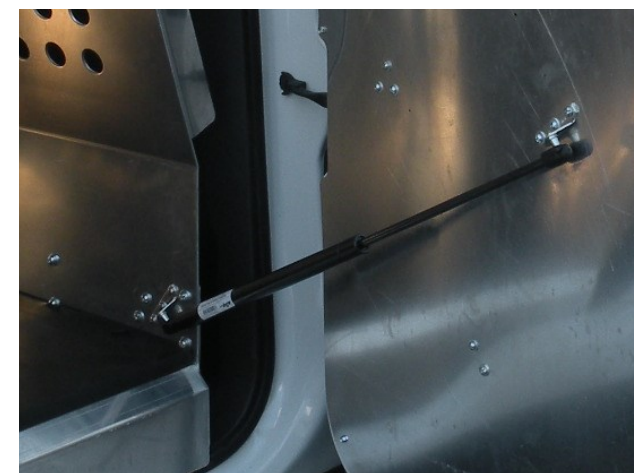

Step 15
Door Cover Panel to PS Door

Ensuring that the power supply cable of Fan for the K9 Unit has been removed, Rivet the Door Cover Panel to the PS Door. Use AL Rivets

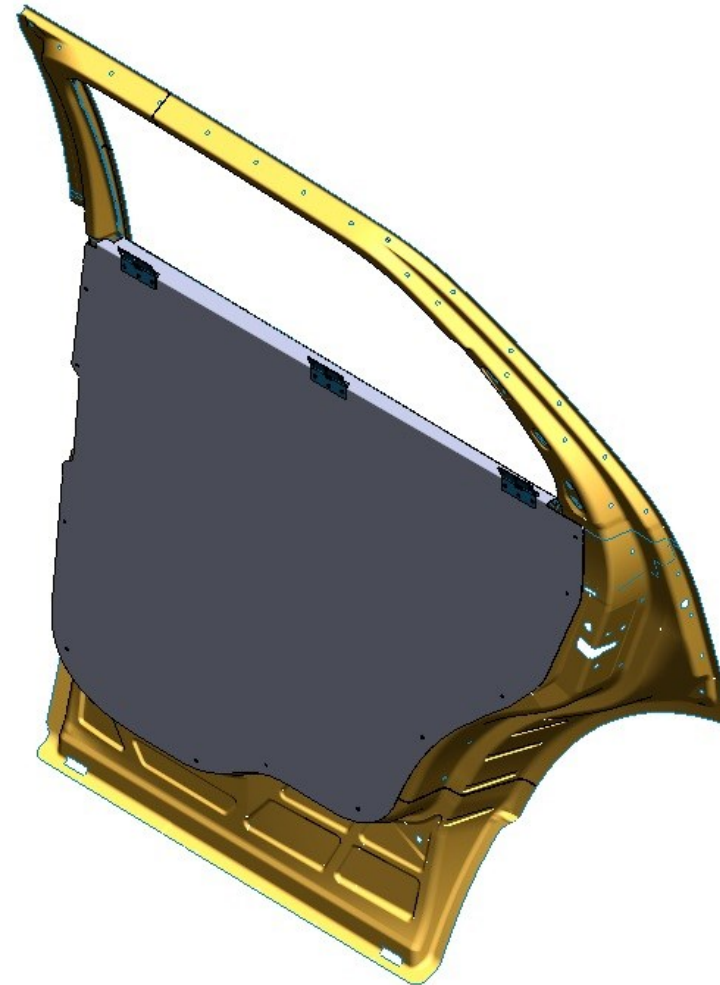

Step 16
Window Guard to Hinges

Place the supplied window guard panel and rivet to the hinges. Use AL Rivets

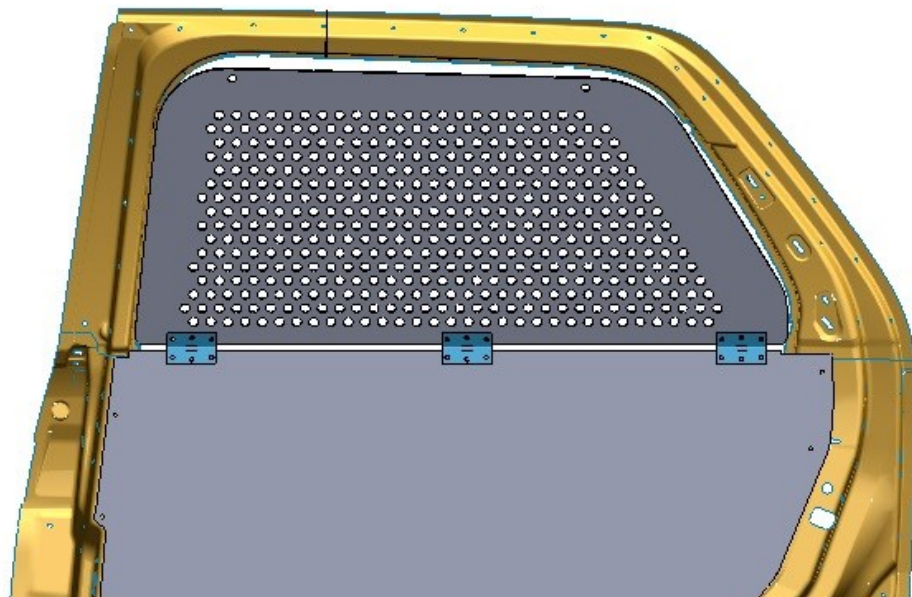

VEHICLE PREPARATION

Remove the 2 rear seats and set aside. The removed bolts will be used to fasten the sub-frame to the floor. Remove Passenger Side Rear door panels and set aside.

INSTALLATION OF K9 UNIT

Step 1
Sub-frame into Vehicle

Place sub-frame over the seat mount holes. Some cutting of factory foam will be required to set the sub-frame into position. Secure using factory seat Bolts.

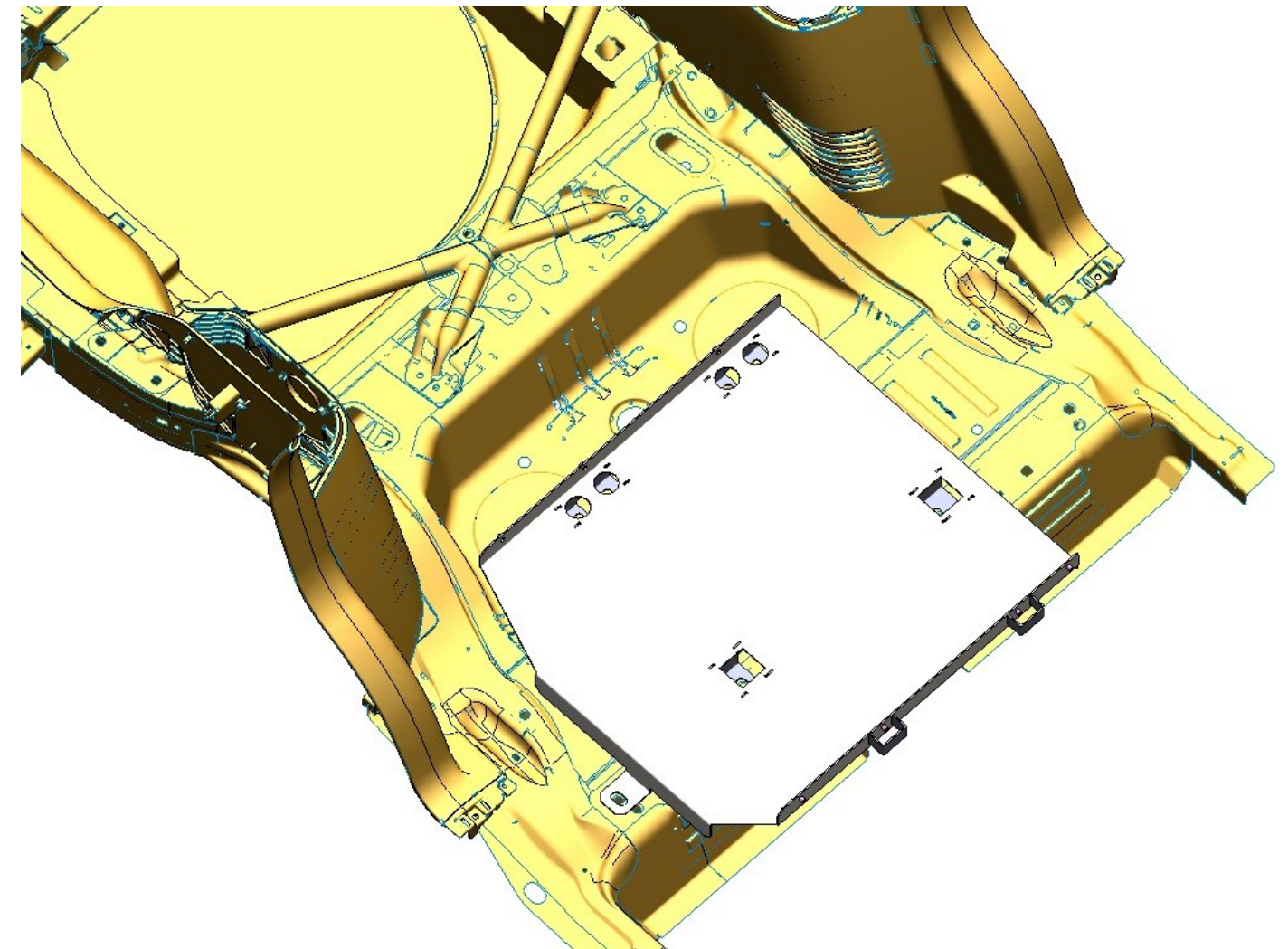

Step 2
Base Panel to Sub-frame

Place base panel on sub-frame. Do not secure.

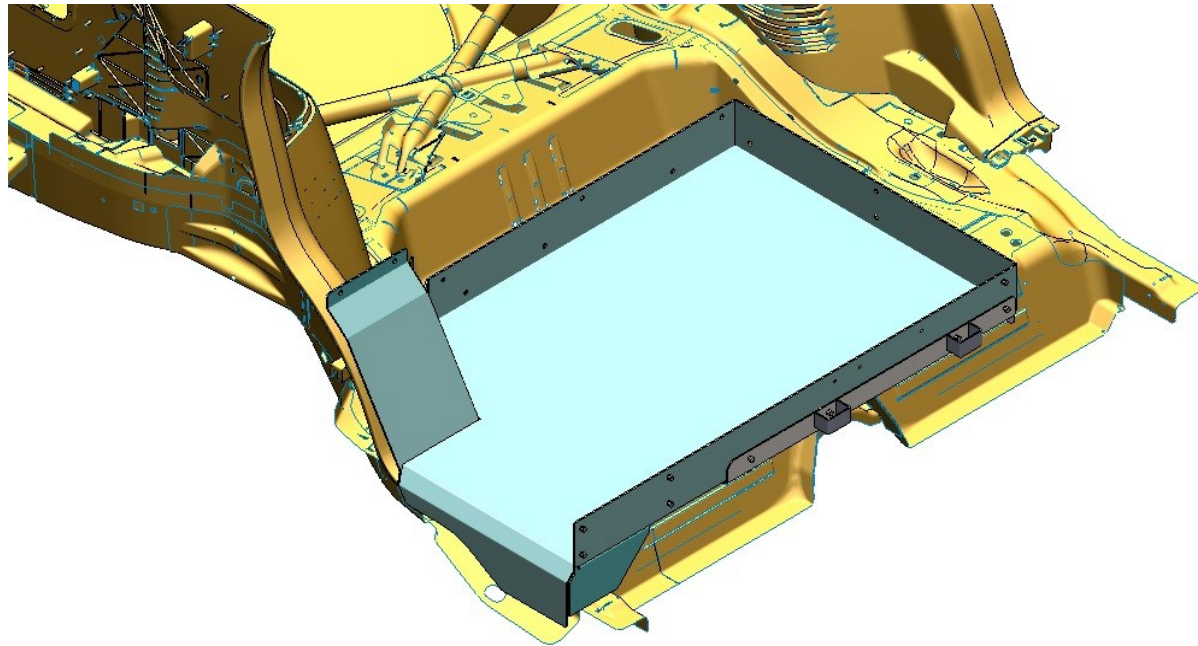

Step 3
Front Panel to Base Panel

Place Front panel on Base Panel and secure with Sub-frame using (9x) 1/4-20 -5/8" Hex Bolt, 1/4" Lock Washer and 1/4" Flat Washer

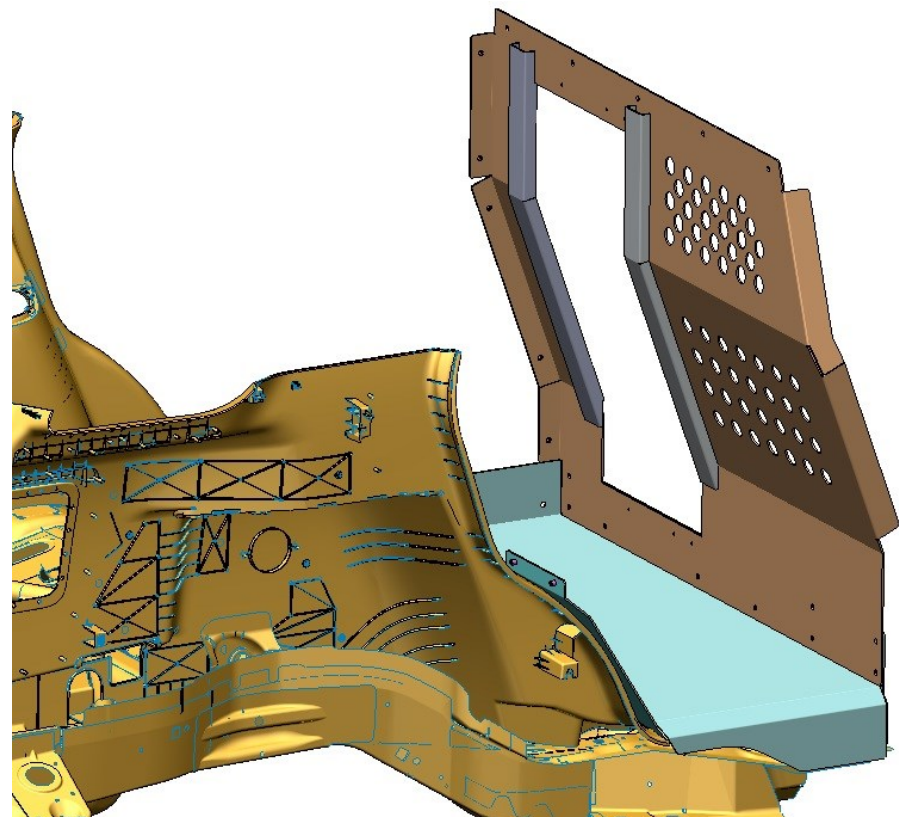

Step 13
Rubber Mat

Place Rubber Mat into the Kennel.

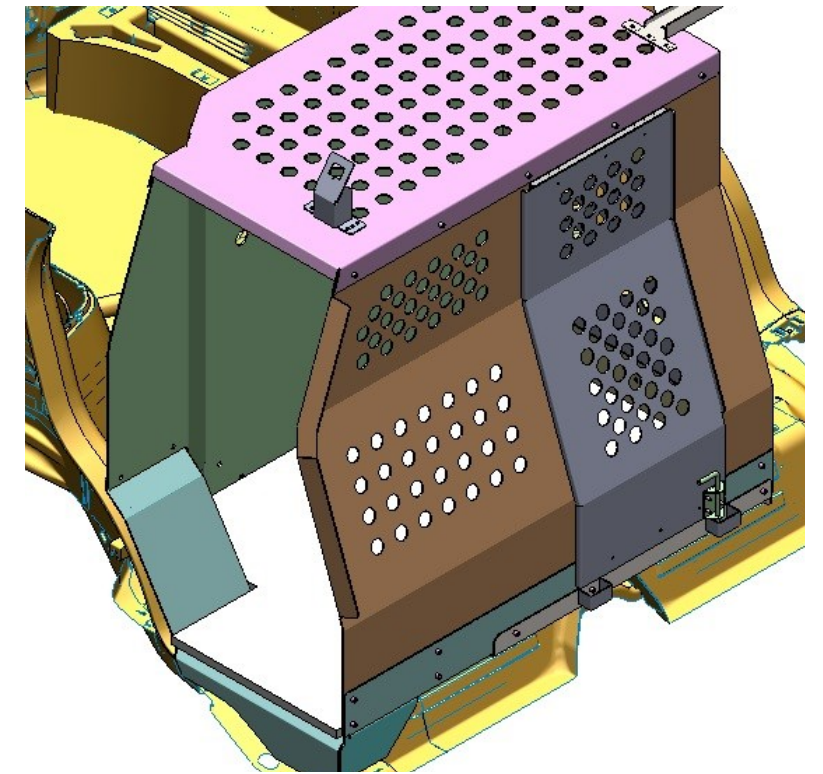

Step 14
Hinges to Door Cover Panel

Place (3x) Butt Hinges as shown and rivet to Door Cover Panel. USE AL Rivet.

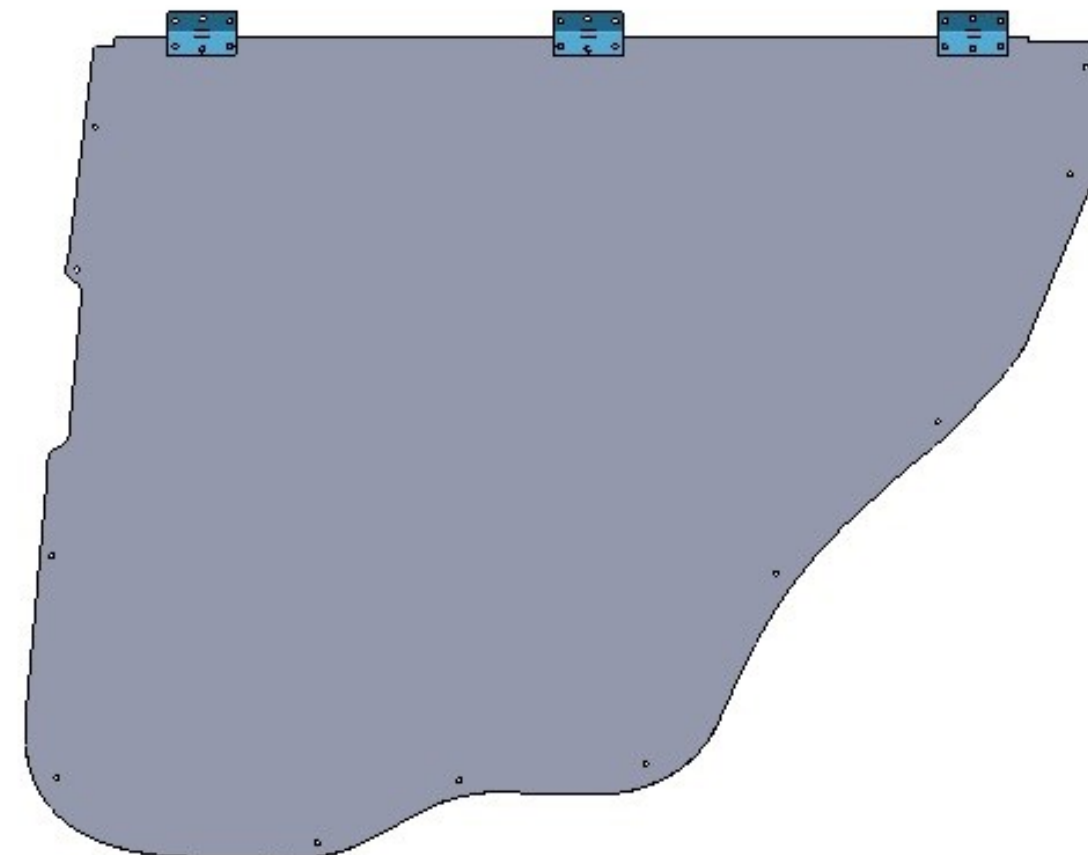

Step 10
Front Door to Front Panel

Place Front Door onto Front panels by locking inner and outer slides into each other.

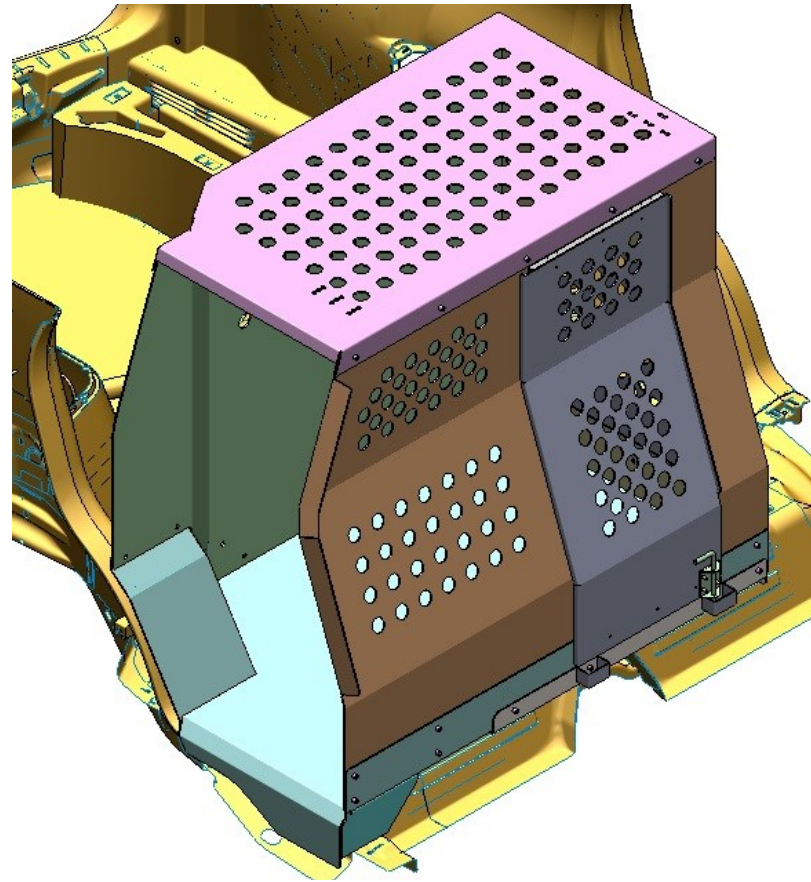

Step 11
Top Brackets to Top Panel and Roof Coat Hooks

Place Top Brackets on the Top Panel and secure to Roof Coat Hooks, above rear doors, using (8X)1/4-20 x 5/8" Hex Bolt, (8x) 1/4-20 Nylock Nuts, (16x) 1/4" Flat Washers.

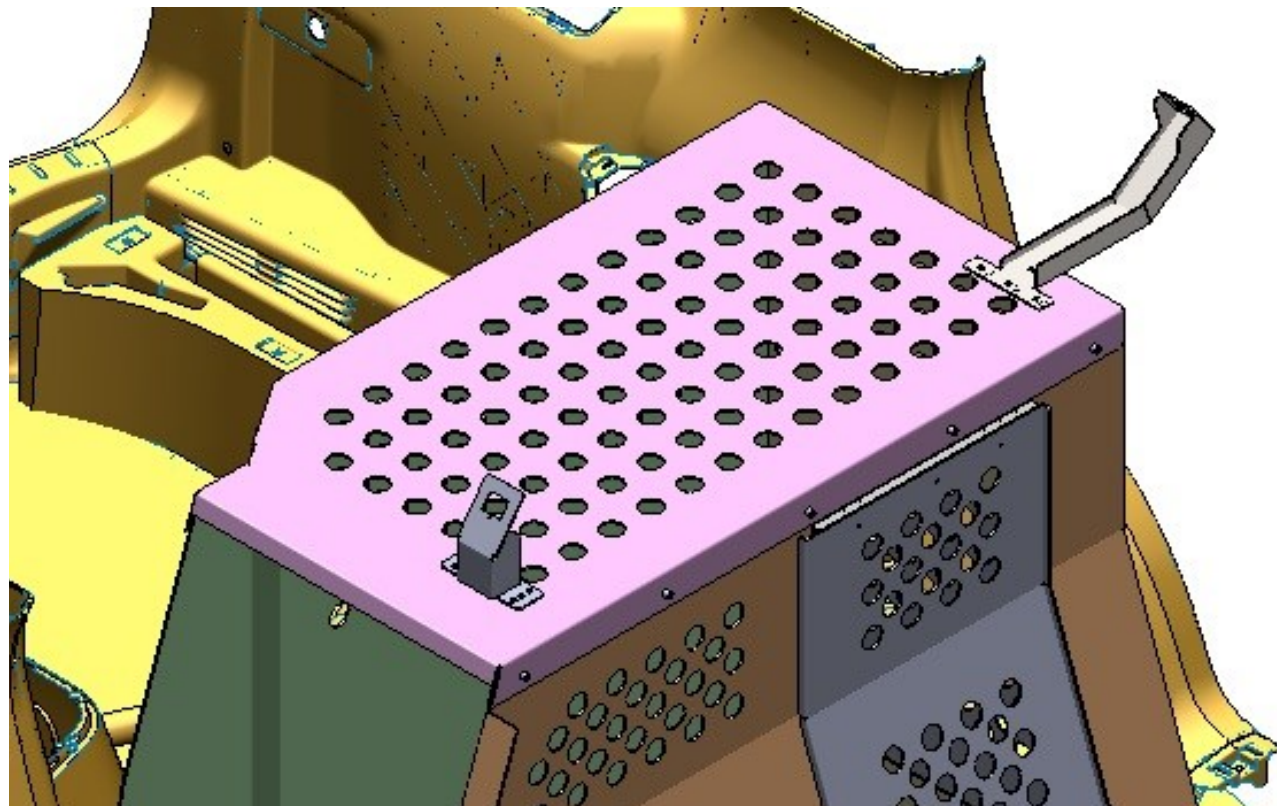

Step 4
Rear Panel to Base Panel

Place Rear Panel on Base Panel and secure with Sub-frame using (10x) 1/4-20-5/8" Hex Bolt, 1/4" Lock Washer and 1/4" Flat Washer

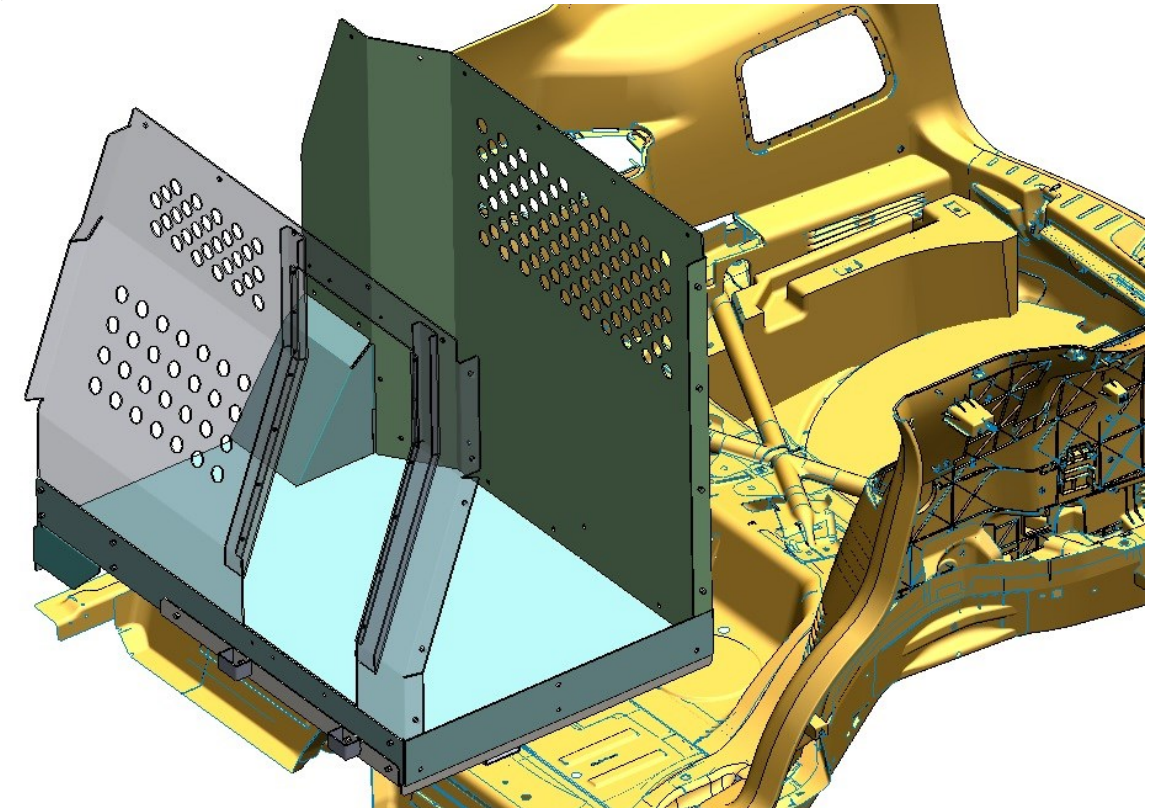

Step 5
Top Panel to Front and Rear Panel

Place Top Panel on Front and Rear Panel and secure using (11x) 1/4-20-5/8" Hex Bolt, 1/4" Lock Washer and 1/4" Flat Washer.

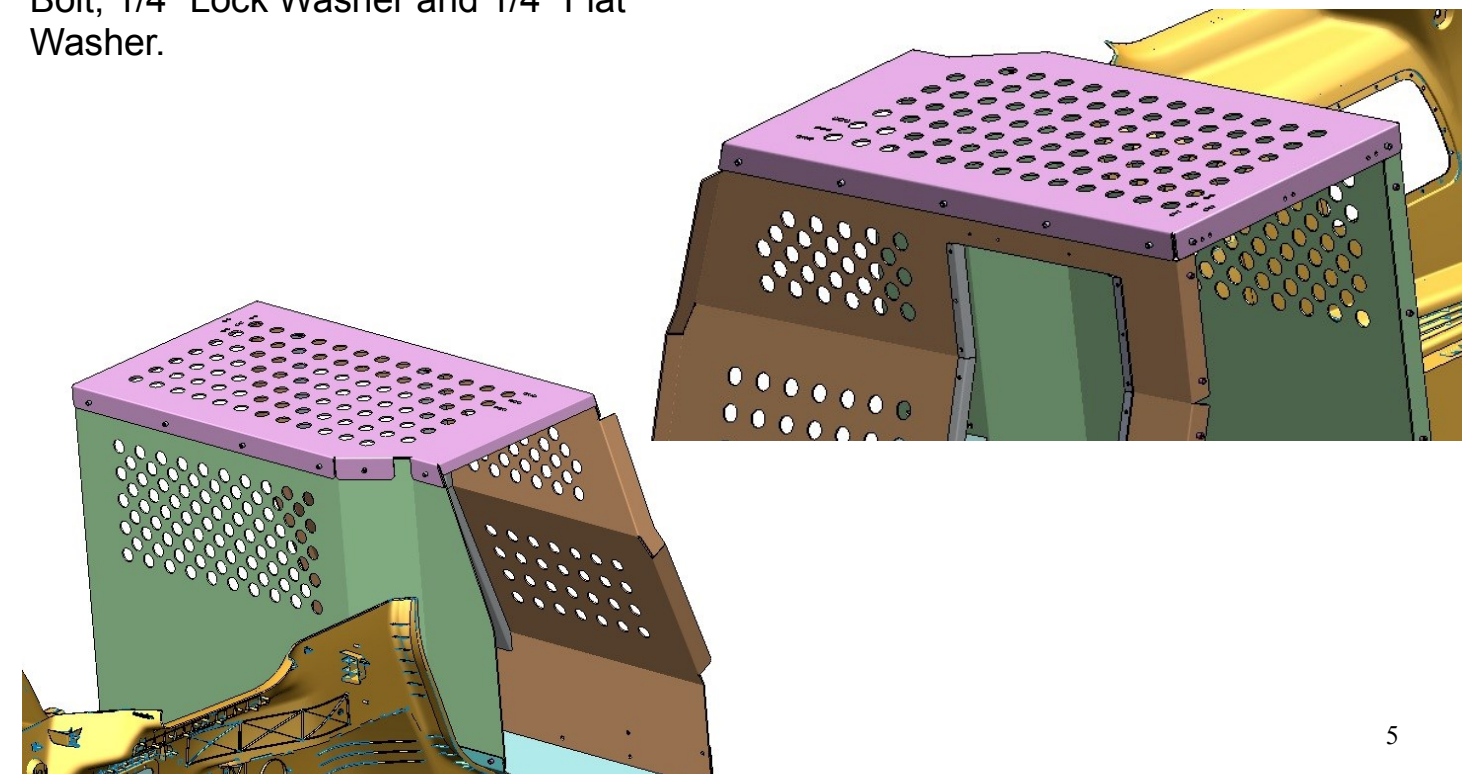

Step 6
Side Panel to all Panels

Place Side on the inside from PS Door and secure using (15x) 1/4-20-5/8" Hex Bolt, 1/4" Lock Washer and 1/4" Flat Washer

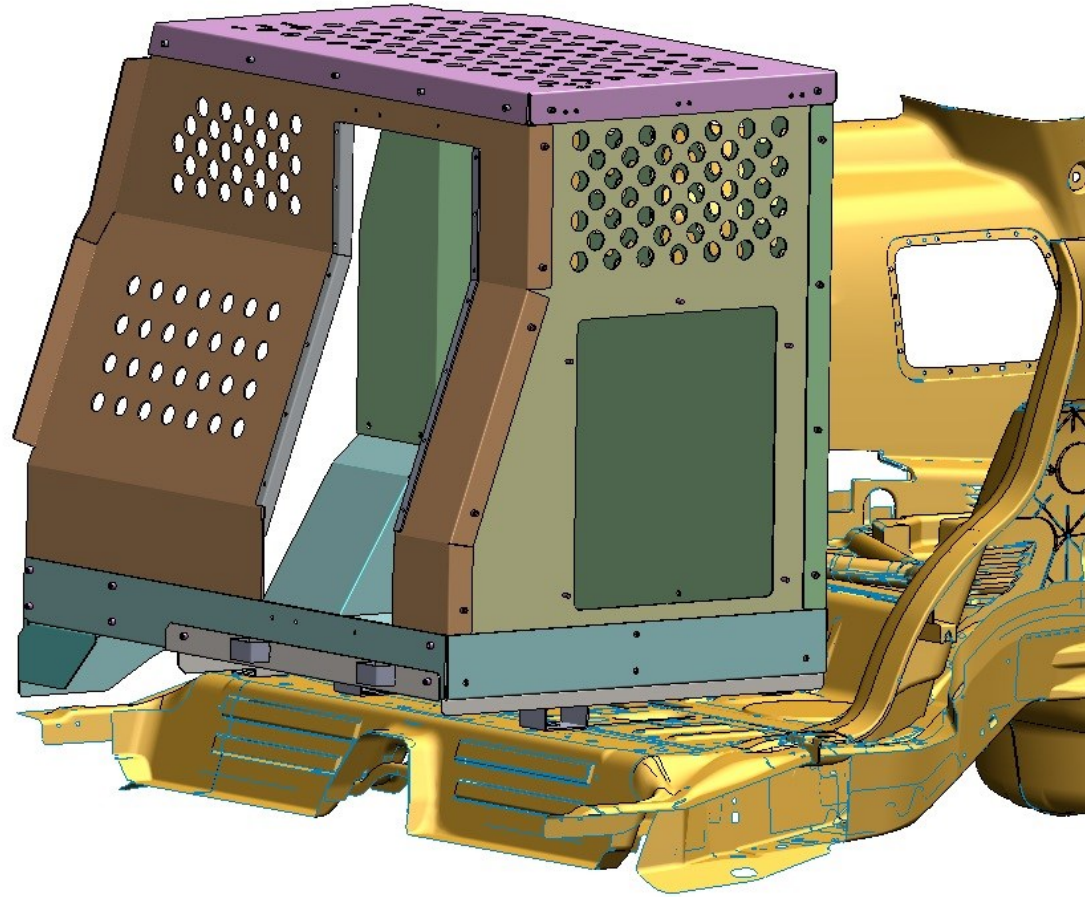

Step 7
Side Panel Cover

Place Cover Panel over side panel and secure with (5x) plastic nut.

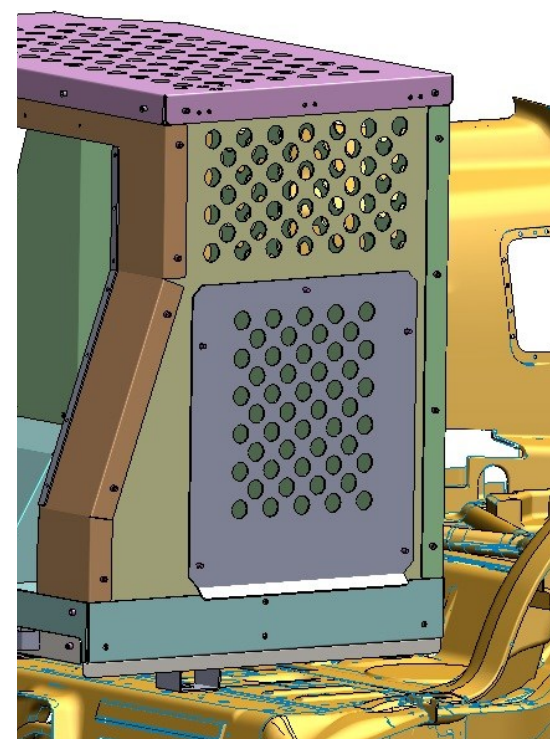
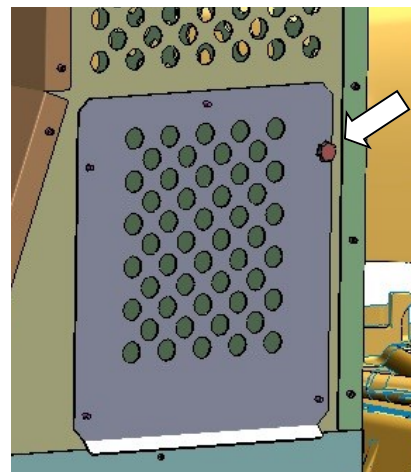

Step 8
Outer Slides to Front Panel

Place (2x) Outer Slides on Front Panel and secure using (6x) 10-32 Bolts, Lock Washers and Flat Washers

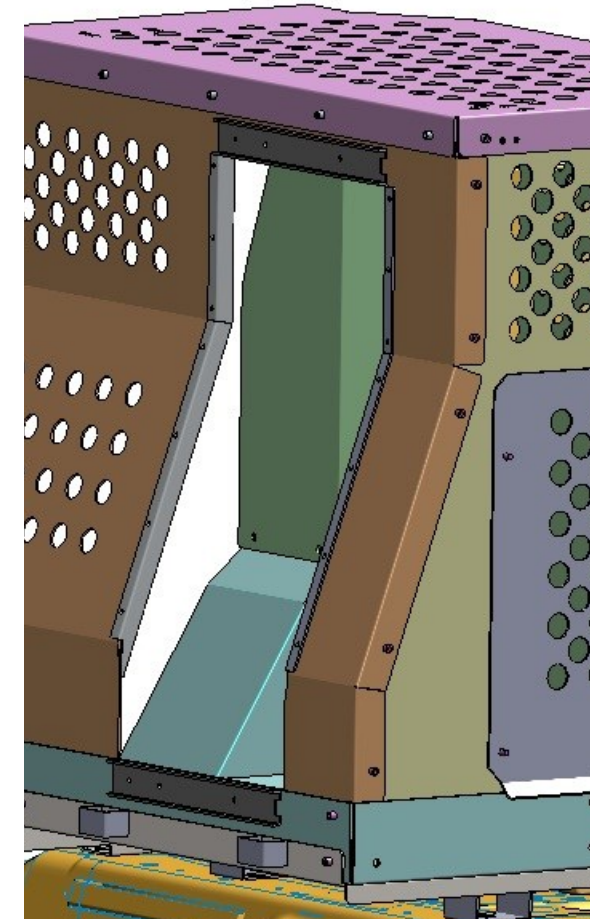

Step 9
Inner Slides and Latch to Front Door

Place (2X) inner Slides on Front Door and secure using (6x) 10-32 Bolts, Lock Washers and Flat Washers

