

REV.	DESCRIPTION	BY	DATE	APPROVED

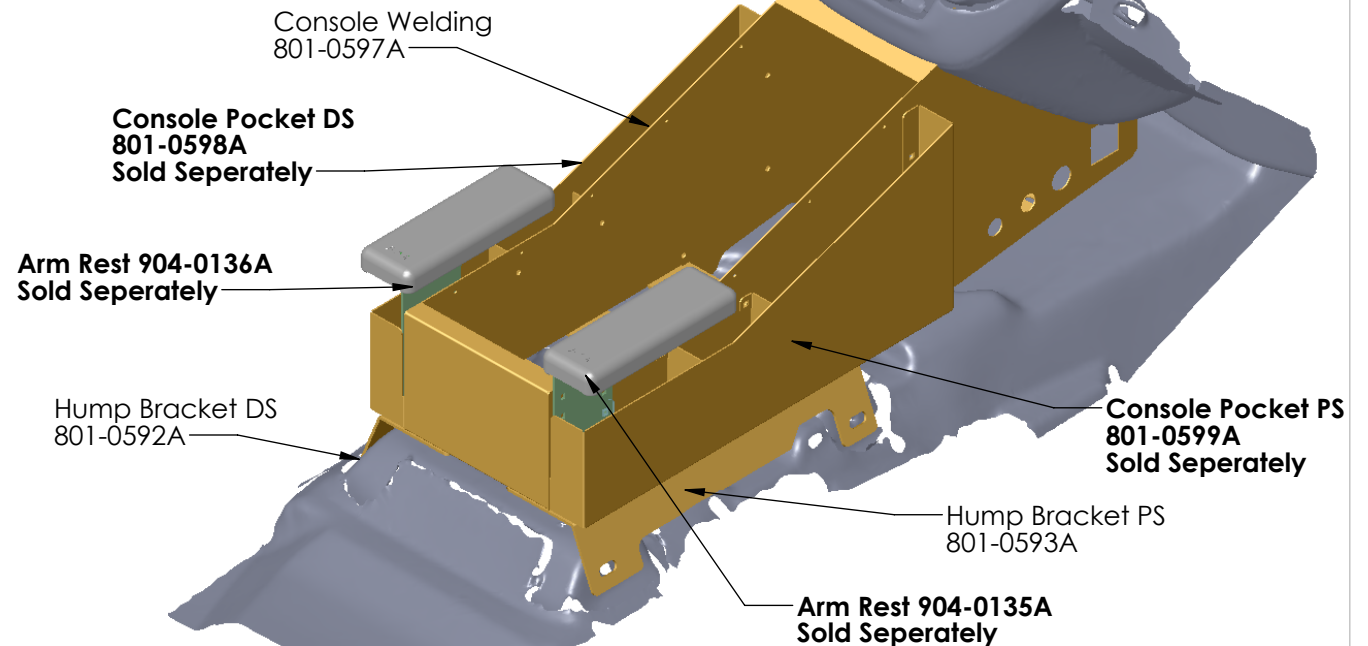

**Hardware List:**

- 4x - 1/4-20 x 3/4" Carriage Bolt
- 4x - 1/4" Flat Washer
- 4x - 1/4-20 Nylock Nuts
- 2x - Spacers

**Standard Features:**

- Cutouts for Factory 110V & 12V outlets relocation
- Additional 2x 12V Power Outlets
- Rugged Structure
- 21.75" (14" on incline+7.75") of Mountable Faceplate Room.
- Maximum Depth of 8" for mounting radii.

**Available Features:**

- Various Faceplate and Console Accessories
- Console Side Pockets
- Single or Separate Armrests

NAME	DATE	<b>DANDR ELECTRONICS CO.</b>	DANDR-ANSI-A	SIZE
DRAWN	26AUG14		REV2	<b>A</b>
CHECKED	AD	26AUG14	Path: Y:\MECH ENG\MECH_DESIGN\2015 Tahoe Contour Console\ File: 901-0128A Date: Wednesday, October 08, 2014 8:07:16 AM	
THE INFORMATION CONTAINED WITHIN THIS DRAWING IS PROPRIETARY AND CONFIDENTIAL. AND IS THE SOLE PROPERTY OF DandR ELECTRONICS CO. LTD. IT MAY NOT BE REPRODUCED AT WHOLE OR IN PART WITHOUT THE WRITTEN PERMISSION OF DandR ELECTRONICS CO. LTD.			<b>DESCRIPTION:</b> <h3>2015 Tahoe Console</h3>	
			MFG. NO.	CATALOG. NO.
FINISH			USED ON:	SHEET 1 OF 1
Midnight Black Wrinkle			901-XXXX	REV. 0
MATERIAL			14 ga CRS	