

2020 Utility Rear Window Guards
(937-0362A)
Installation Manual

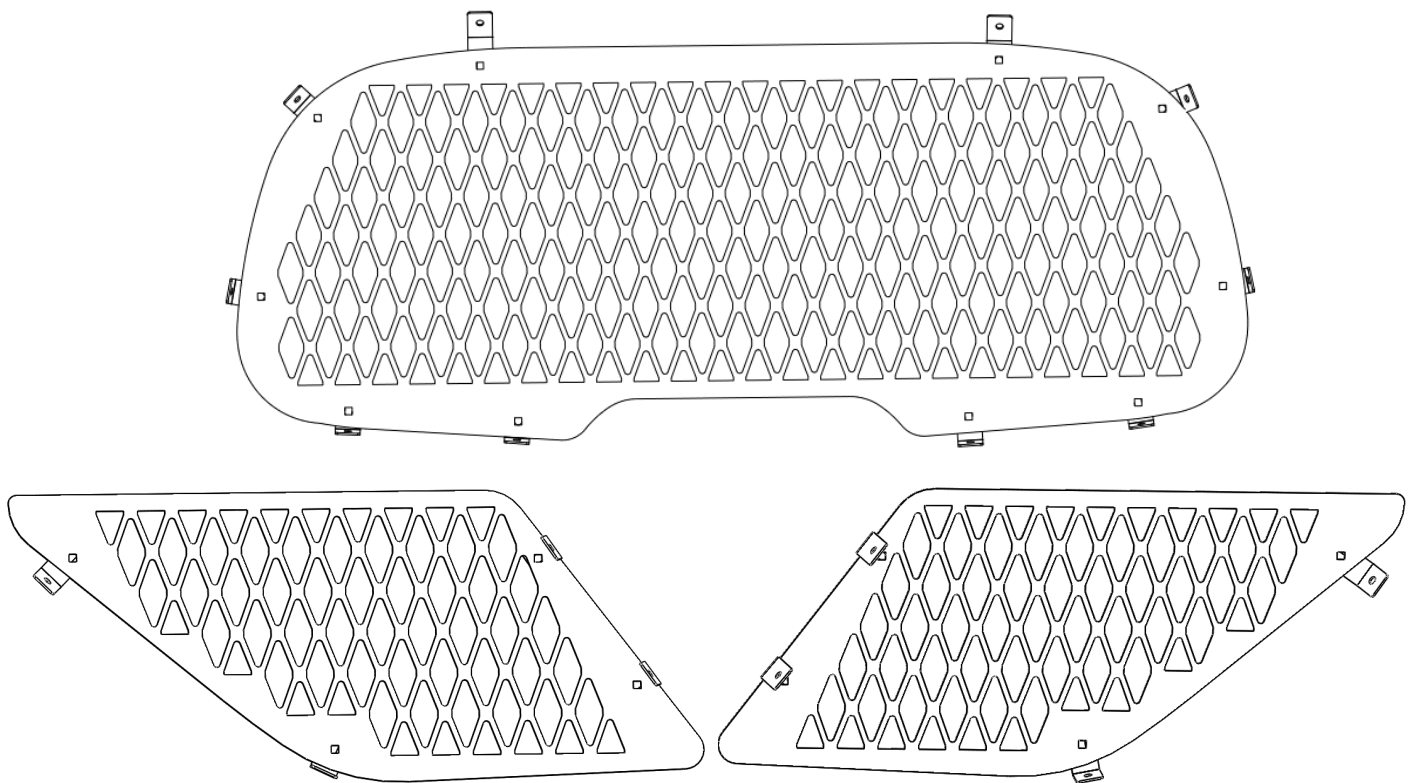

Content	Page
Hardware and Component List	2
Installation Instructions	3-4
Warranty and Return Policy	5

Hardware List

Part Number	Description	Qty
401-0031	1/4-20 x 1/2" Carriage Bolt	18
403-0043	3/8" Flat Nylon Washer	18
422-0009	1/4-20 Nyloc Nut	18
411-0150	1/4-20 x 3/4" Tex Hex	18
403-0004	1/4-20 Lock Washer	18
403-0005A	1/4-20 Flat Washer	18

Component List

Item Number	Part Number	Description	Qty
A	837-0502A	Rear Window Guard (small)	2
B	837-0503A	Bracket A (75°)	4
C	837-0504A	Bracket B (120°)	4
D	837-0505A	Bracket C (98°)	8
E	837-0506A	Bracket D (140°)	2
F	837-0507A	Rear Window Guard (large)	1

Installation Instructions

INTERIOR SIDE BACK WINDOW GUARDS

Step 1:

- A. Test fit window guard without mounting brackets.
- B. Mount the mounting brackets on the window guards using 1/4-20 x 1/2" Carriage Bolts (4x), 3/8" Flat Nylon Washers (4x) and 1/4-20 Nyloc Nuts (4x). Tighten just enough so that the brackets can still be adjusted.

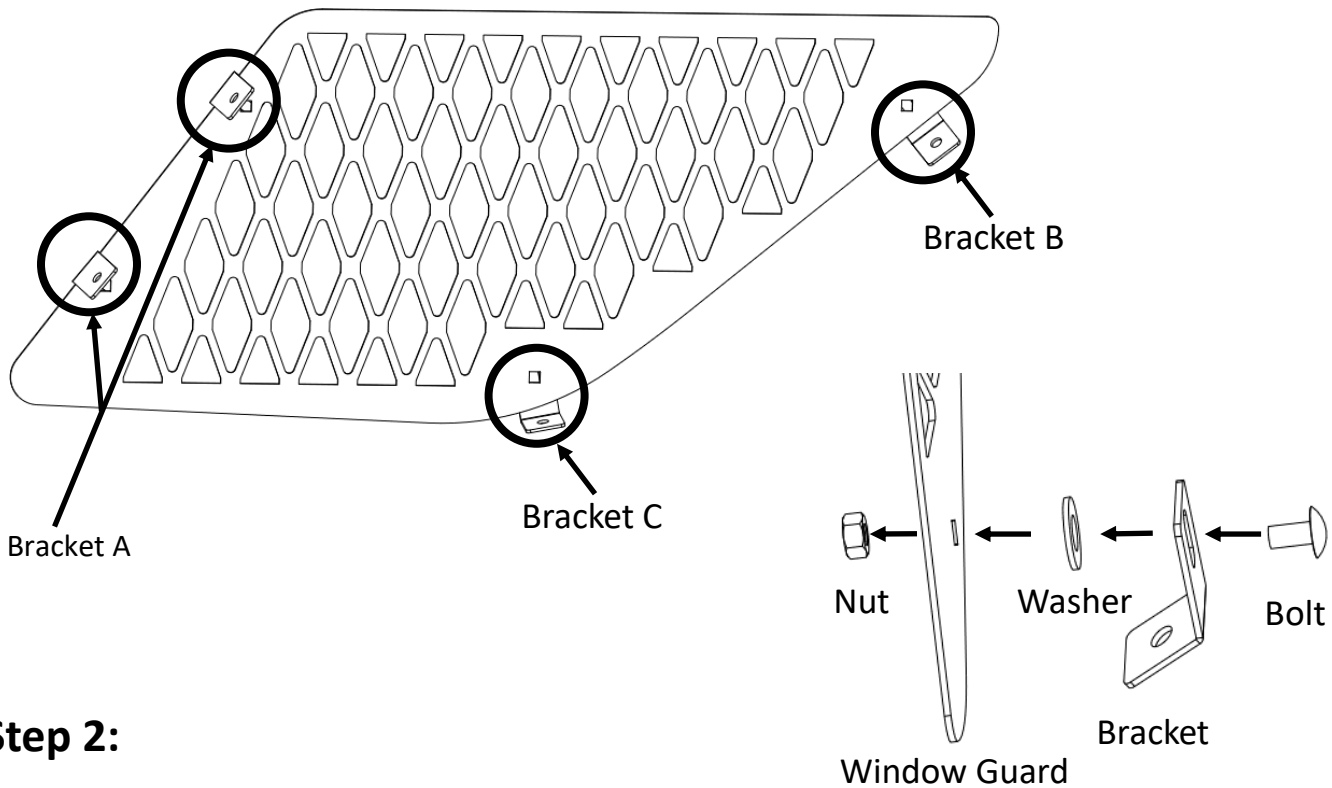

Step 2:

- A. Test fit the window guard and adjust brackets as necessary.
- B. **Carefully** secure the assembly with self tapping screws provided.
- C. Tighten the Nyloc Nuts located on the window guards.

Repeat for passenger side window guard. Not shown.



FOR BACK WINDOW GUARDS

Step 3:

- Test fit the window guard without mounting brackets.
- Mount the mounting brackets on the window guards using 1/4-20 x 1/2" Carriage Bolts (10x), 3/8" Flat Nylon Washers (10x) and 1/4-20 Nyloc Nuts (10x). Tighten just enough so that the brackets can still be adjusted.

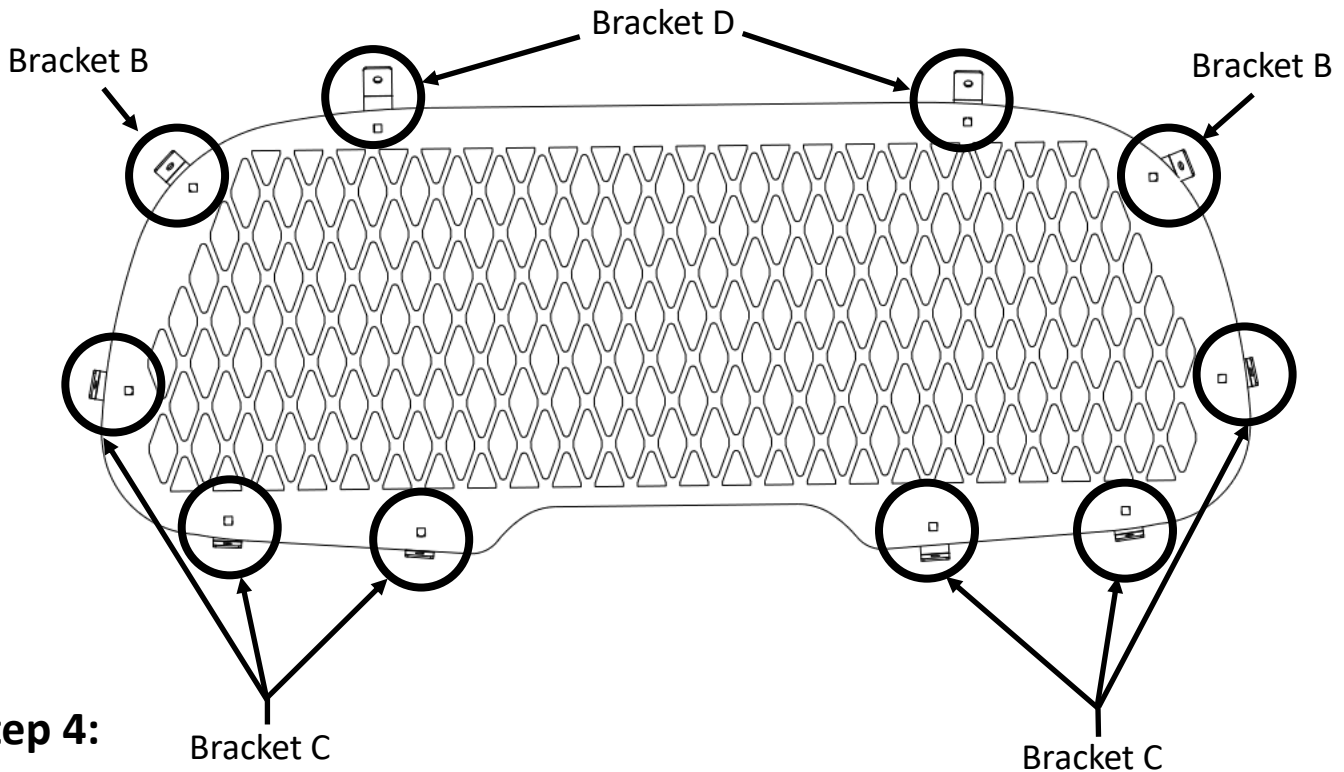

Step 4:

- Test fit the window guard and adjust brackets as necessary.
- Carefully** secure the assembly with self tapping screws provided.
- Tighten the Nyloc Nuts located on the window guards.

Inspect to see if window guard is secure.



Installation is complete.

WARRANTY

D & R Electronics warrants its new products to be free from defects in material and workmanship, under normal use and service, for a period of one year on parts replacement, and one year on labor.

This warranty applies only to original purchasers acquiring the product directly from D&R Electronics, or its authorized dealers. Warranty will not be recognized without proof of purchase or bill of sale. This warranty is not transferable.

The warranty begins on the date of delivery to the first user/purchaser. This warranty shall not apply to products which must be repaired due to normal wear and tear, negligence, improper installation, abuse, misuse, or which have been

altered or modified at a facility other than D & R Electronics, or its authorized depot center. Units proved to be defective within the warranty period, based on an examination by D&R Electronics, will be replaced or repaired at D & R Electronics' option. This warranty does not cover travel expenses or labor charges for removal or installation. Lamps, flash tubes, batteries or other items considered consumables are not covered under warranty.

This warranty is in lieu of all other express warranties. D&R Electronics makes no other warranties, expressed or implied, than the express warranties contained herein.

PRODUCT RETURN POLICY

In order to provide you with faster service, product returns for repair or replacement, must have a **Return Goods Authorization Number (RGA number)**. Please contact our company to obtain a RGA number before you return the product to D & R ELECTRONICS. Write the RGA number clearly on the package. Be sure you use sufficient packing materials to avoid damage to the product being returned while in transit.

D & R ELECTRONICS assumes no responsibility or liability for expenses incurred for the removal and/or the installation of products requiring service and/or repair. Repairing or replacing product is at the discretion of D & R ELECTRONICS.

D&R ELECTRONICS Co. LTD.

CANADA

8820 George Bolton Pkwy.
Bolton, Ontario L7E 2Y4

Tel.: (905)951-9997
Fax: (905)951-0019

USA

2299 Kenmore Ave
Building #3, Doors 11-14
Buffalo, NY, 14207

Toll Free 1-800-538-7338

www.dandrelectronics.com