

**NOTE: SUBFRAME ONLY FITS CABINETS WITH 20" DEPTH**

REV.	DESCRIPTION	DCR	BY	DATE	APPROVED
------	-------------	-----	----	------	----------

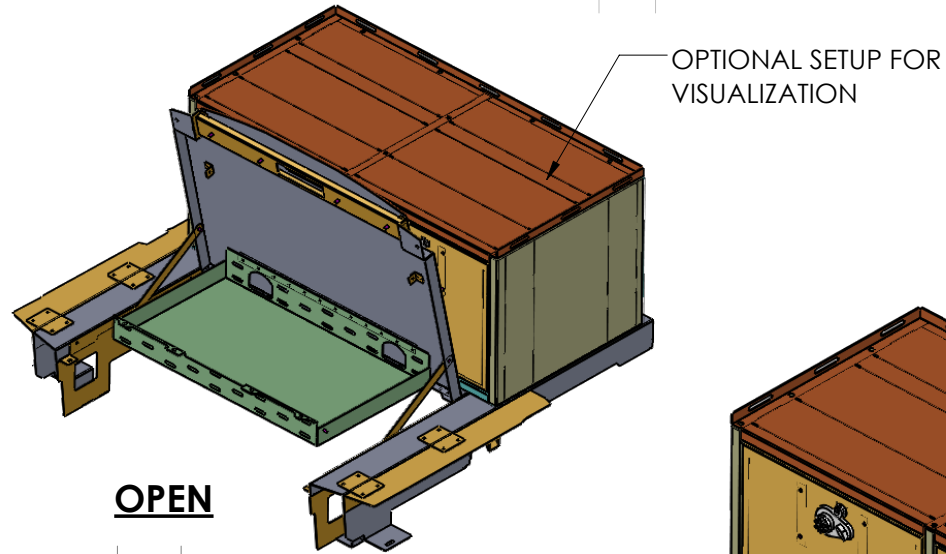

**OPEN**

7.96

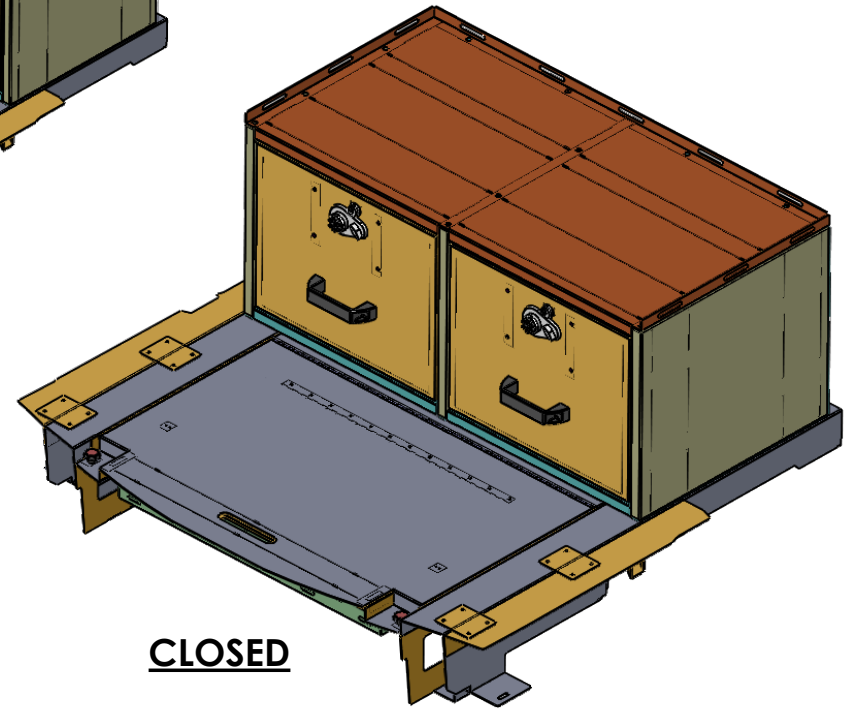

**CLOSED**

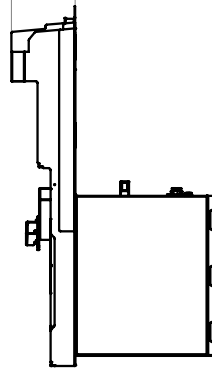
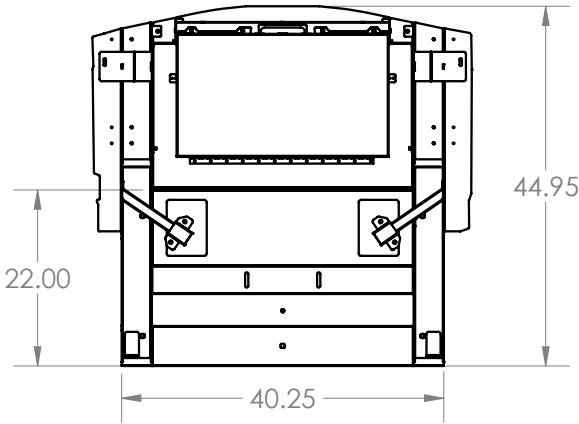
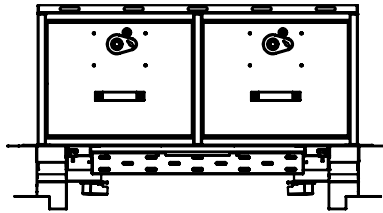

QTY	DESCRIPTION	PART NUMBER
8	10-32 X 3/4" Machine Screw Zinc	401-0013
8	#10 Lock Washer Zinc	403-0010
8	#10 Flat Washer Zinc	403-0007A
4	1/4-20 X 1" Bolt Zinc	401-0025
6	1/4" Lock Washer Zinc	403-0004
6	1/4" Flat Washer Zinc	403-0005
6	3/8 Cage Nut	407-0015A
6	3/8-16 X 1" Bolt Zinc	401-0042
6	3/8" Flat Washer Zinc	403-0008
6	3/8" Lock Washer Zinc	403-0013
2	M6 X 1" Machine Bolt Zinc	

NAME	DATE	DCR	DESCRIPTION	REV	DATE	APPROVED	SIZE	
IM	03JULY20		Path: M:\MECH_DESIGN\IM Design\933-0138A - 2020 Utility Subframe with Spare Tire Access File: 933-0138A Date: July 14, 2020 10:35:35 AM	DANDR-ANSI-A			A	
AD	03JULY20			DESCRIPTION: <b>2020 Ford Utility Subframe (Tire Access)</b>	REV2	APRIL 1, 2009		
FINISH		XX	MFG. NO.		933-0138A	CATALOG. NO.		XXX
			USED ON:		9XX-XXXX			SHEET 1 OF 2
			MATERIAL		XXga CRS			REV.
								0

THE INFORMATION CONTAINED WITHIN THIS DRAWING IS PROPRIETARY AND CONFIDENTIAL AND IS THE SOLE PROPERTY OF DandR ELECTRONICS CO. LTD. IT MAY NOT BE REPRODUCED AT WHOLE OR IN PART WITHOUT THE WRITTEN PERMISSION OF DandR ELECTRONICS CO. LTD.

REV.	DESCRIPTION	DCR	BY	DATE	APPROVED

**CLOSED WITH TRUNK SCAN**

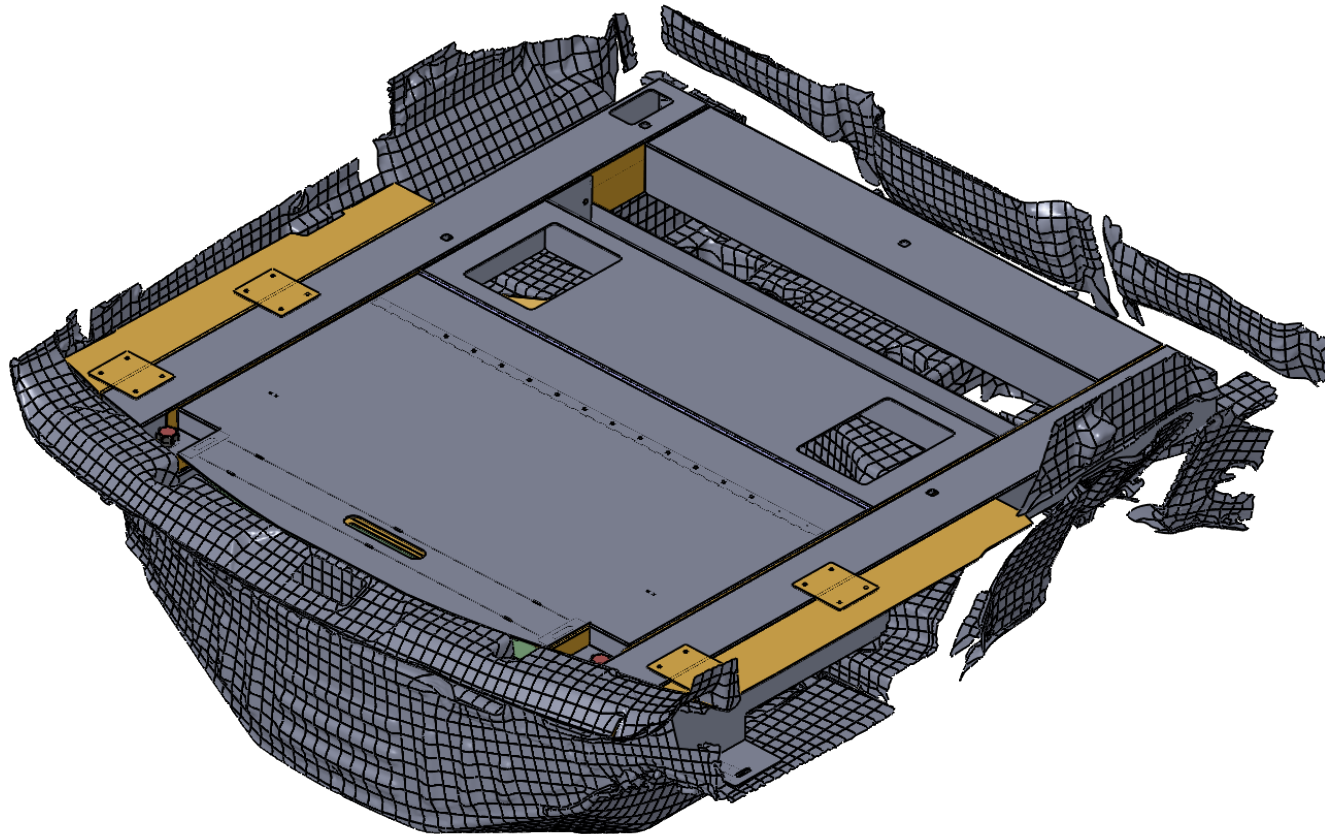

NAME	DATE	DandR ELECTRONICS CO. LTD.		DANDR-ANSI-A REV2 APRIL 1, 2009	SIZE <b>A</b>
DRAWN IM	03JULY20	Path: M:\MECH_DESIGN\IM Design\933-0138A - 2020 Utility Subframe with Spare Tire Access File: 933-0138A Date: July 14, 2020 10:35:35 AM			
CHECKED AD	03JULY20	DESCRIPTION: <b>2020 Ford Utility Subframe (Tire Access)</b>			
THE INFORMATION CONTAINED WITHIN THIS DRAWING IS PROPRIETARY AND CONFIDENTIAL. AND IS THE SOLE PROPERTY OF DandR ELECTRONICS CO. LTD. IT MAY NOT BE REPRODUCED AT WHOLE OR IN PART WITHOUT THE WRITTEN PERMISSION OF DandR ELECTRONICS CO. LTD.		MFG. NO. <b>933-0138A</b>	CATALOG. NO. <b>XXX</b>		
		USED ON: <b>9XX-XXXX</b>	SHEET 2 OF 2		
FINISH <b>XX</b>	MATERIAL <b>XXga CRS</b>		REV. <b>0</b>		