

2020 Utility Rear Subframe (With Tire Access) 933-0138A Installation Manual

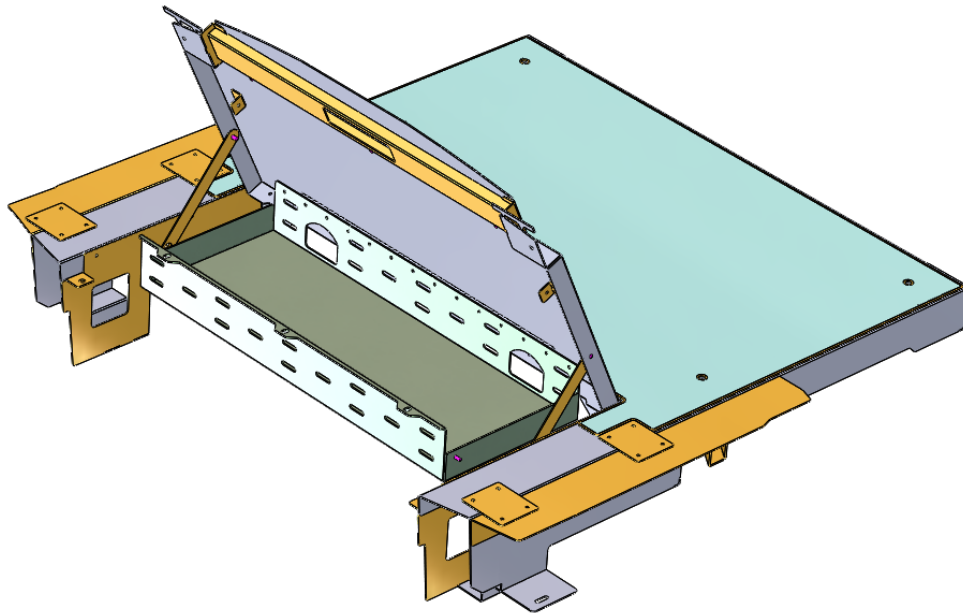

Content	Page
Hardware List	2
Assembly Overview	3-5
Installation Instructions	6-11

Hardware List

Part Number	Description	Qty
401-0013	10-32 X 3/4" Machine Screw Zinc	8
403-0010	#10 Lock Washer Zinc	8
403-0007A	#10 Flat Washer Zinc	8
401-0025	1/4-20 X 1" Bolt Zinc	4
403-0004	1/4" Lock Washer Zinc	6
403-0005	1/4" Flat Washer Zinc	6
407-0015A	3/8 Cage Nut	6
401-0042	3/8-16 X 1" Bolt Zinc	6
403-0008	3/8" Flat Washer Zinc	6
403-0013	3/8" Lock Washer Zinc	6
	M6 X 1" Machine Bolt	2

Component List

Item Number	Part Number	Description	Qty
A	833-1626A	Driver Side Skirt	1
B	833-1627A	Passenger Side Skirt	1
C	833-1432A	Pipe Clamp Bracket	2
D	933-0138A	Rear Subframe	1

Front View

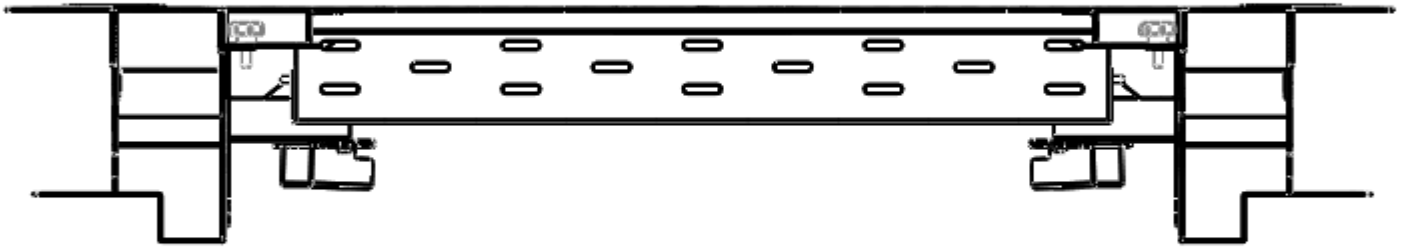

Figure 1.0

Rear View

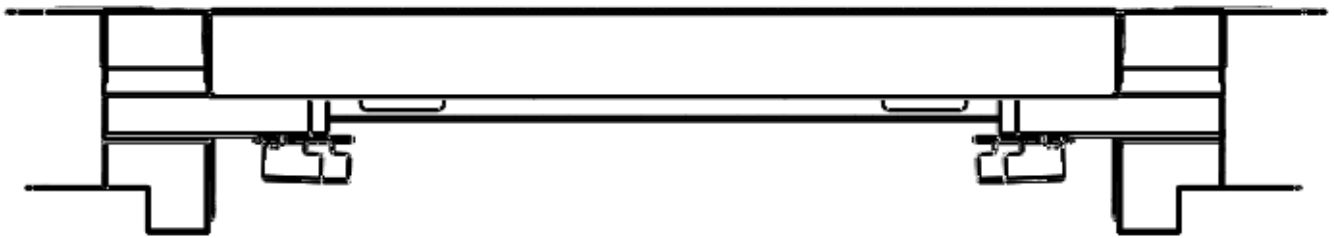

Figure 1.1

Side View

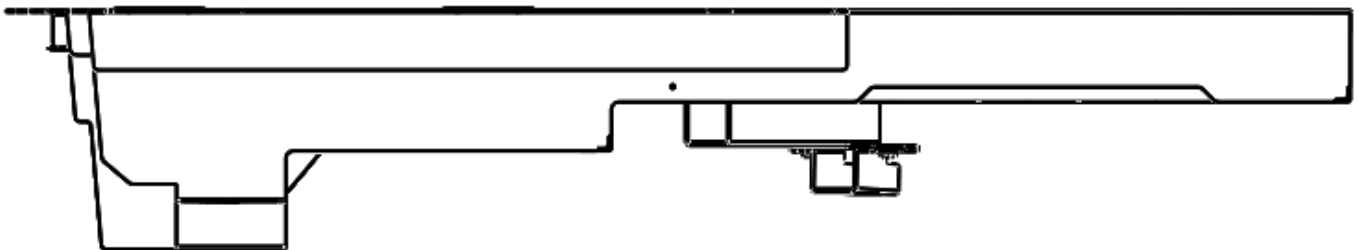

Figure 1.2

Top View

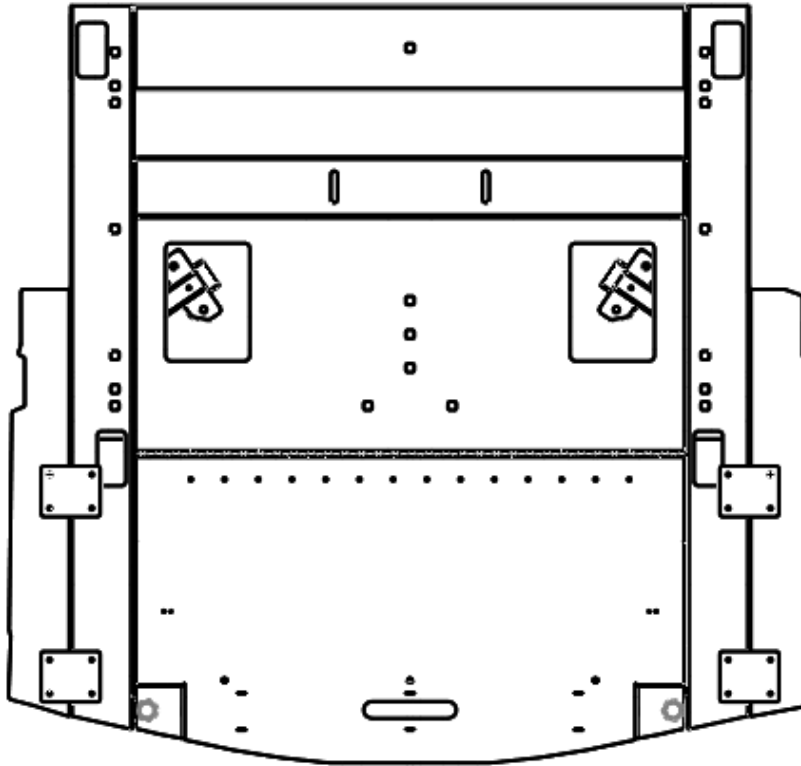

Figure 1.3

Bottom View

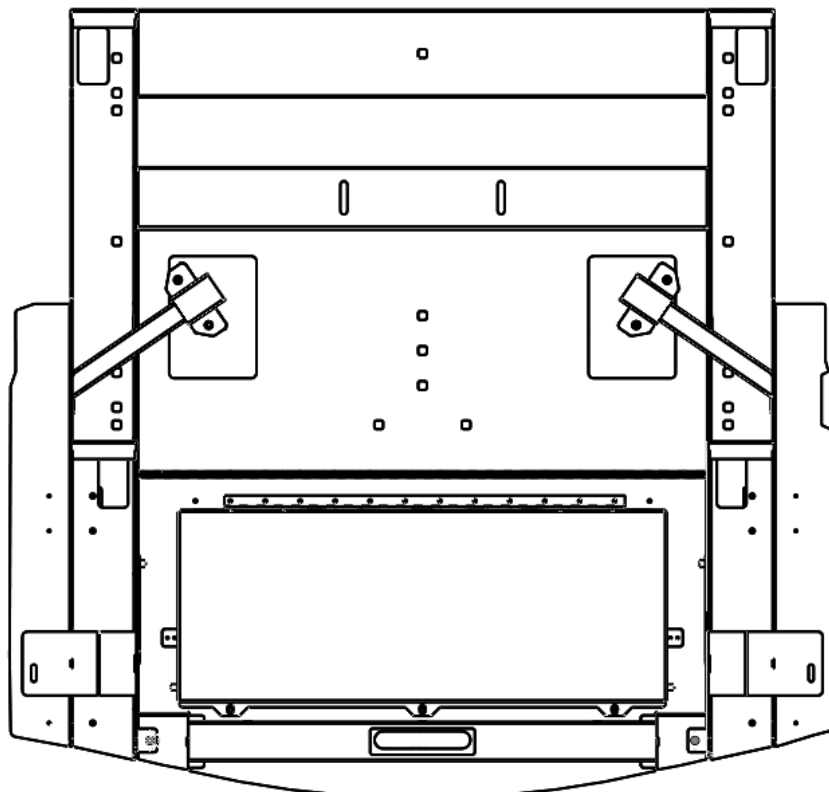

Figure 1.4

Subframe with Cover Plate

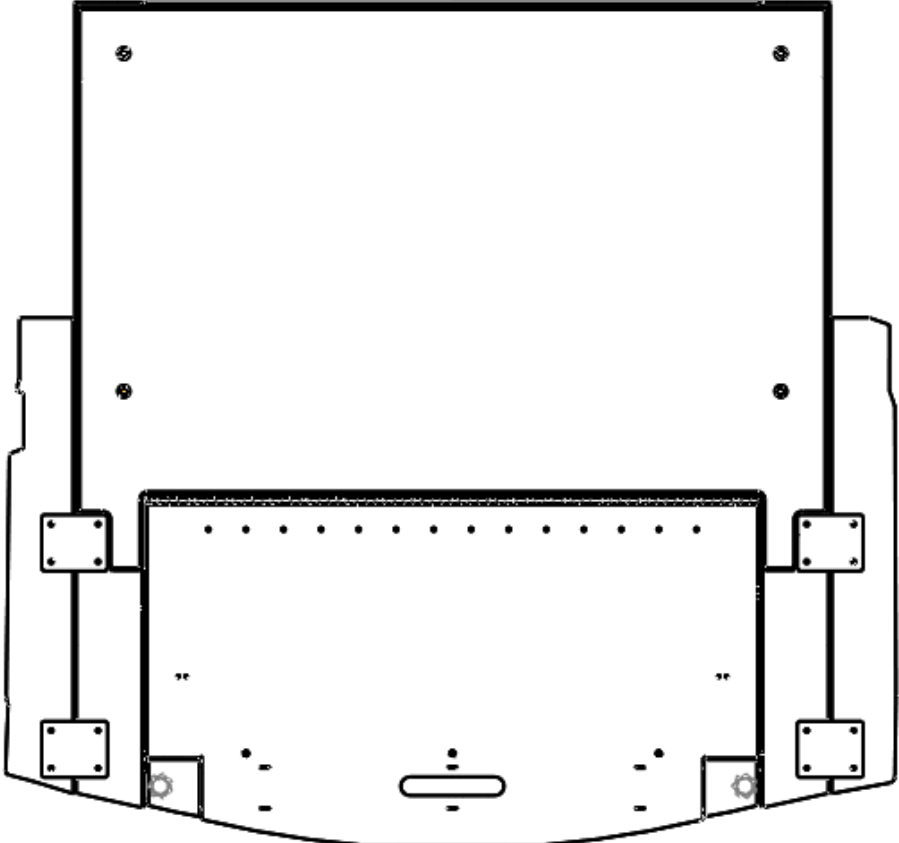

Figure 1.5

Open Position

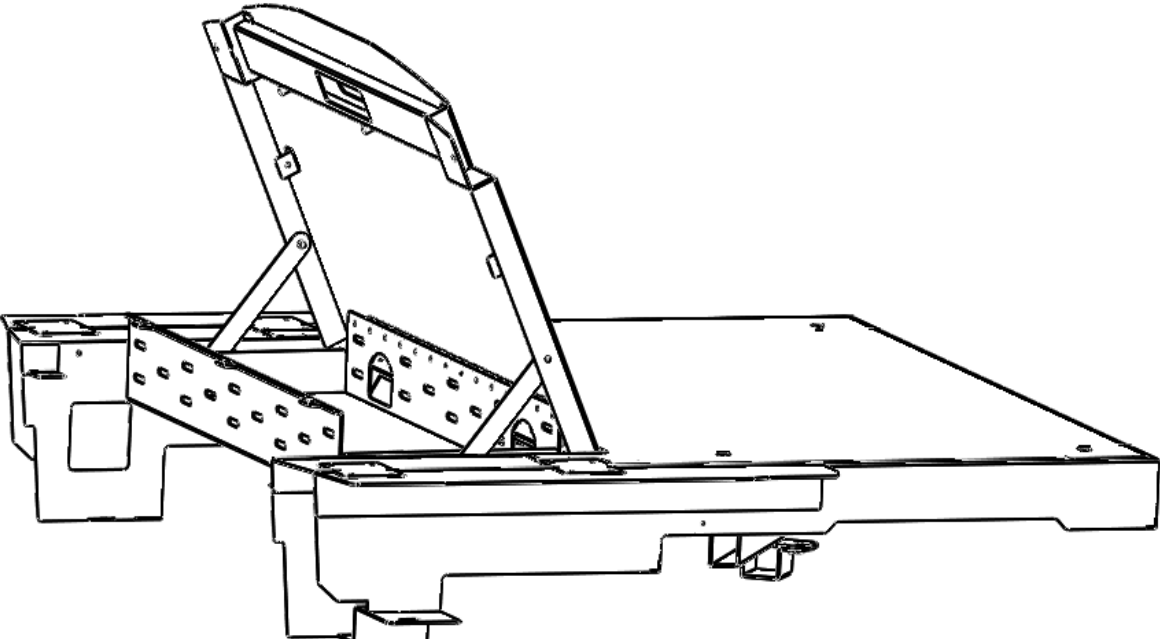

Figure 1.6

Installation Instructions:

Step 1

Lay cabinet onto sub frame. Determine the necessary holes for the mounting. Insert cage nuts before continuing to step 2. Cannot install cage nuts later.

Step 2

Remove the #10 factory from along the side trim along with all the factory foam.

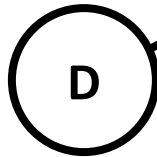

Front of vehicle

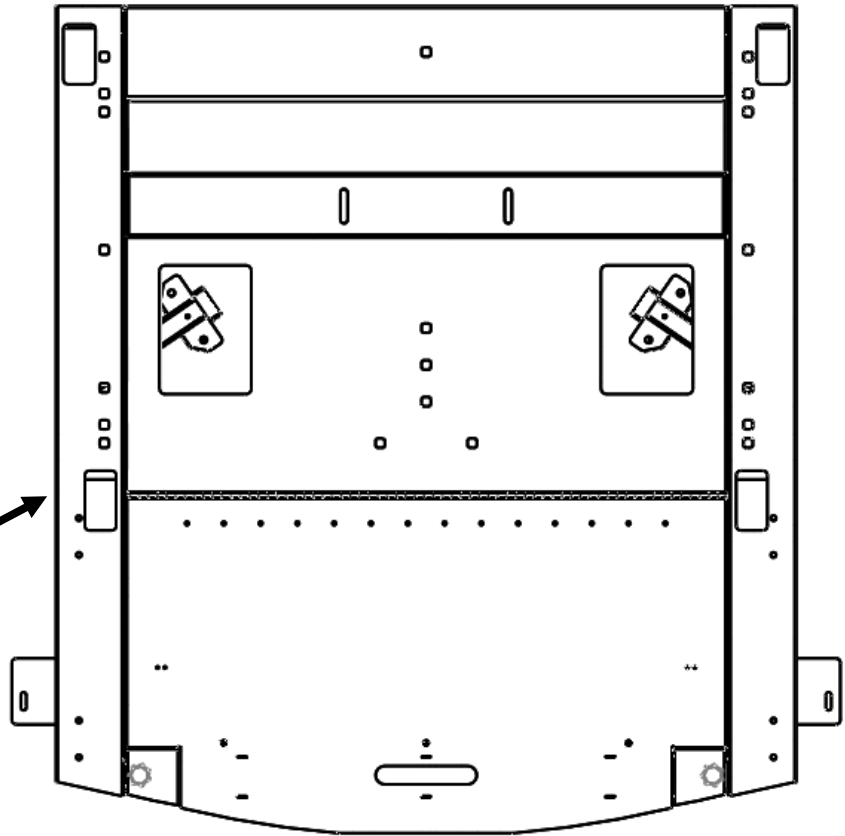

Rear of vehicle



Step 3

Install the 933-0138A liftable subframe into the trunk of vehicle.

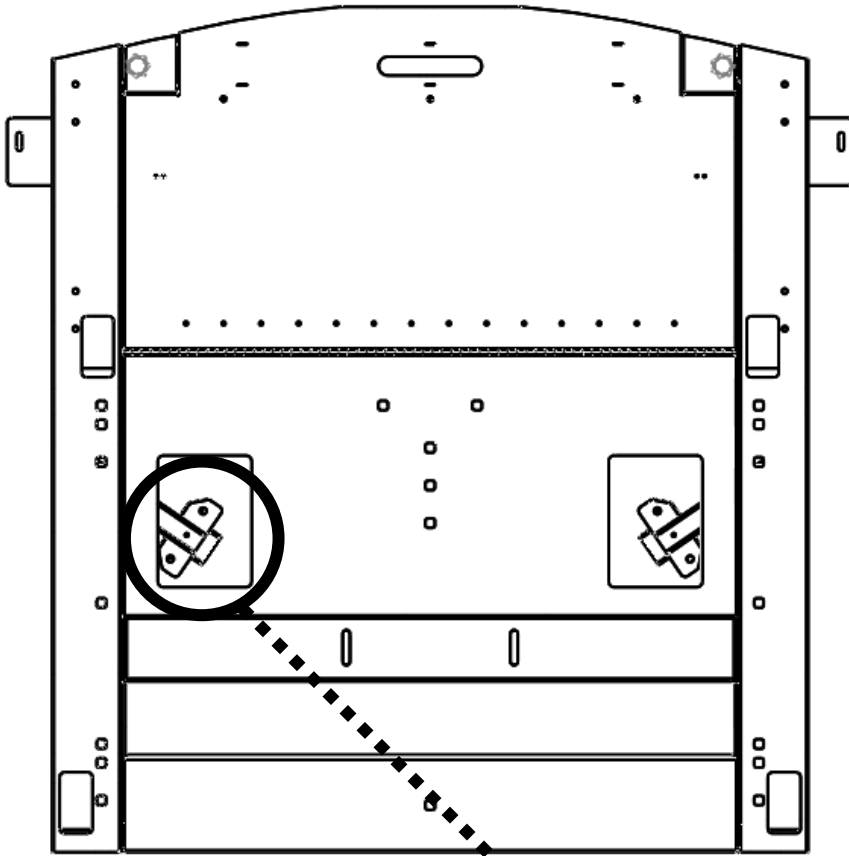

Step 4

Place the pipe clamp bracket under the X-bar utilizing the supplied bolts and washers attach the pipe clamp bracket to the pipe support plate.

- 1/4" Flat Washer X2
- 1/4" Lock Washer X2
- 1/4-20 X 1" Hex bolt X2

C

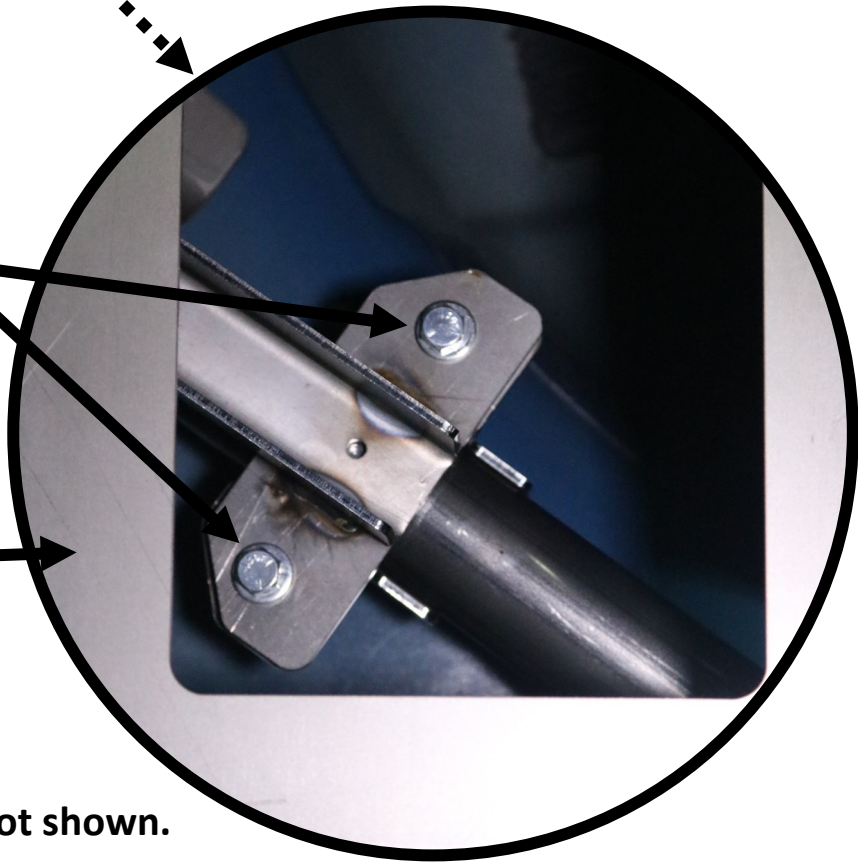

Repeat for the opposite side, not shown.

Step 5

Attach the rear mount leg to the frame of the vehicle using the #10 factory previously removed in Step 1.

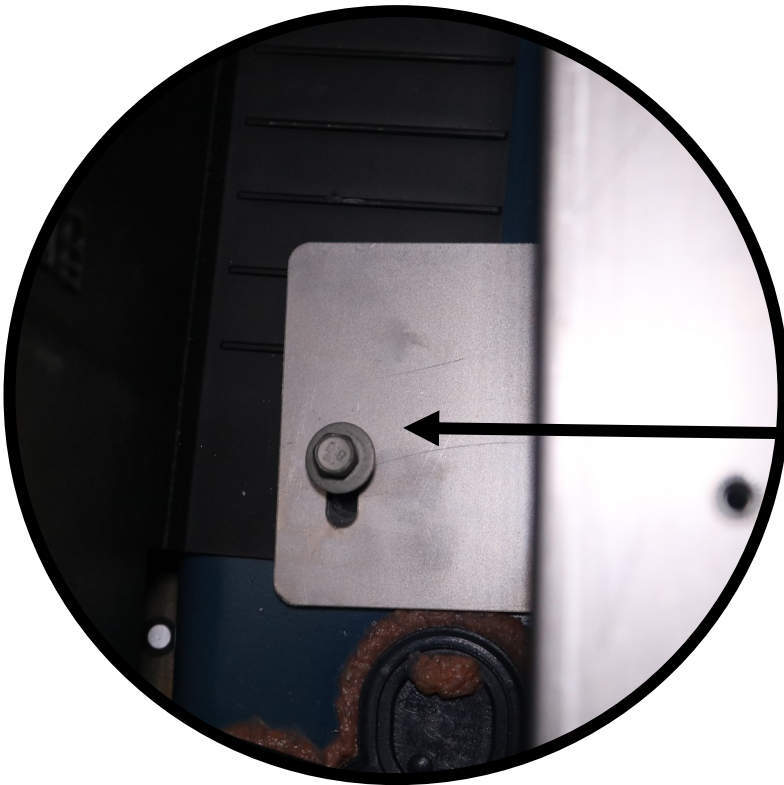
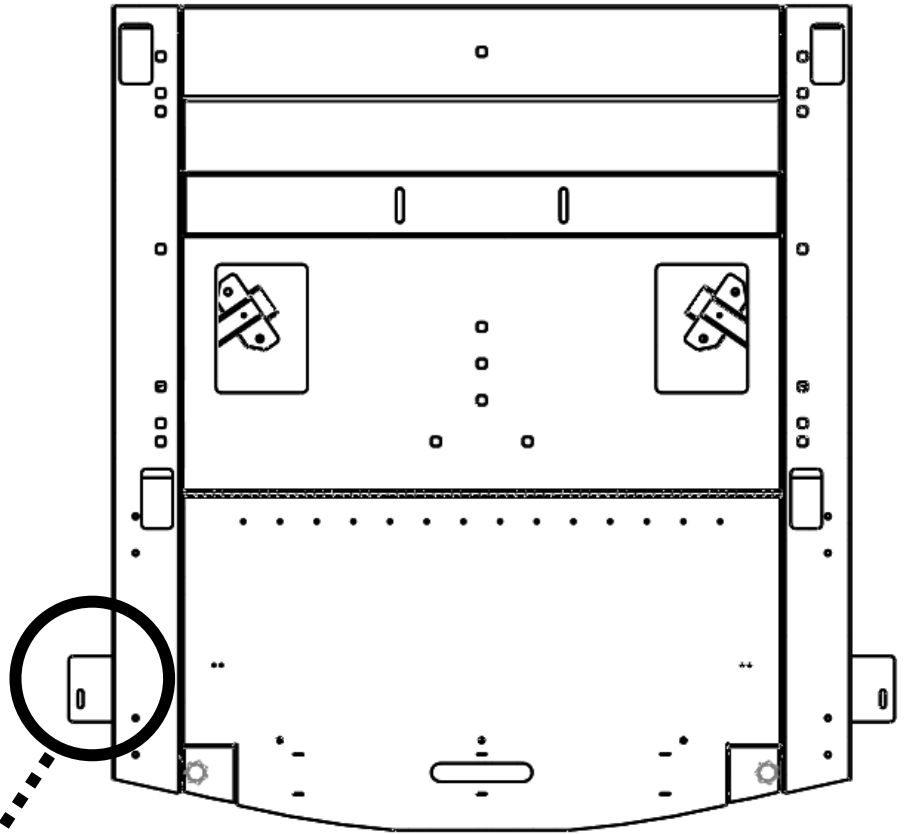

M6 x 1" Bolt
Flat Washer
Lock Washer

Repeat for the opposite side, not shown.

Step 6

Place the filler panels along sides of the sub-frame.

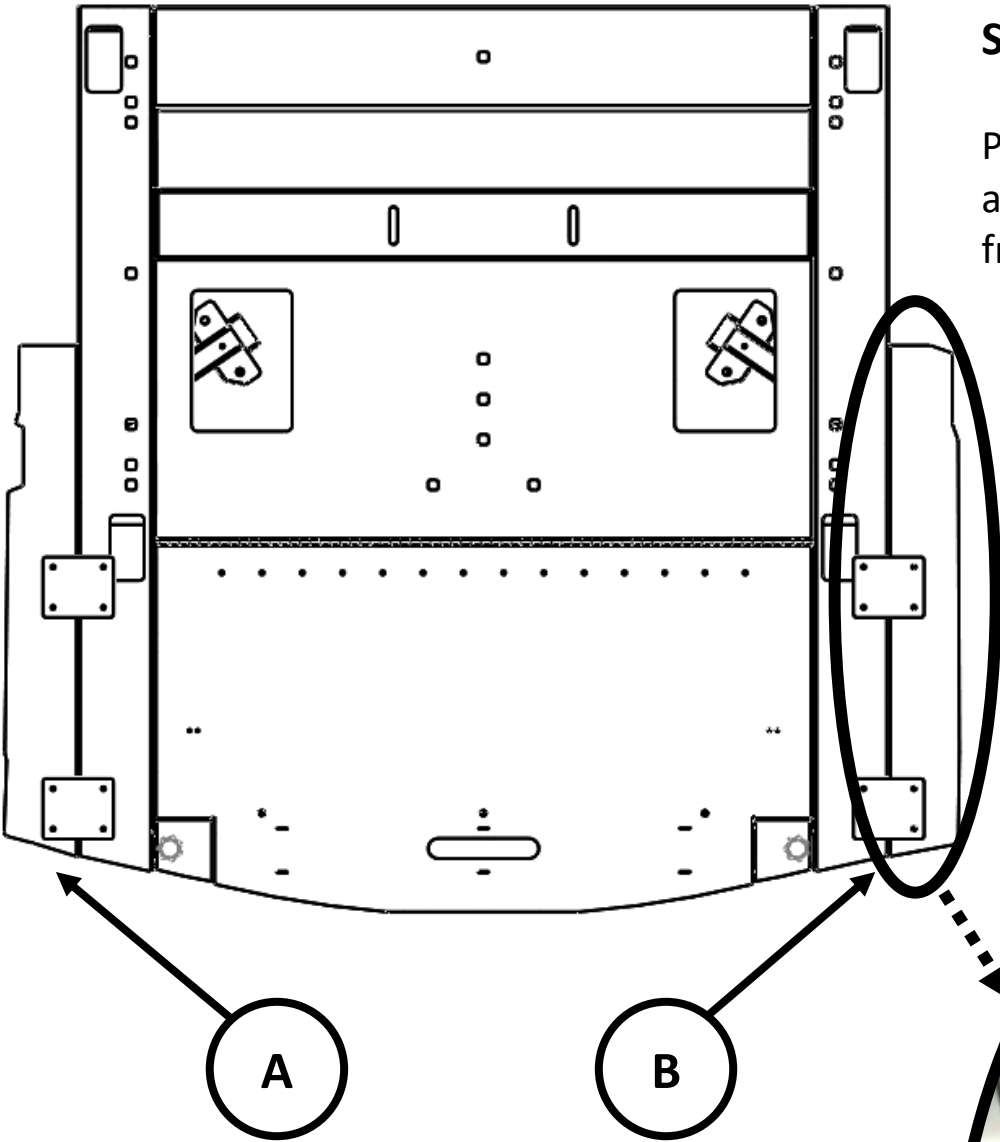

Repeat for the opposite side, not shown.

Step 7

Secure the filler panels to the main body of the subframe using the provided screws.

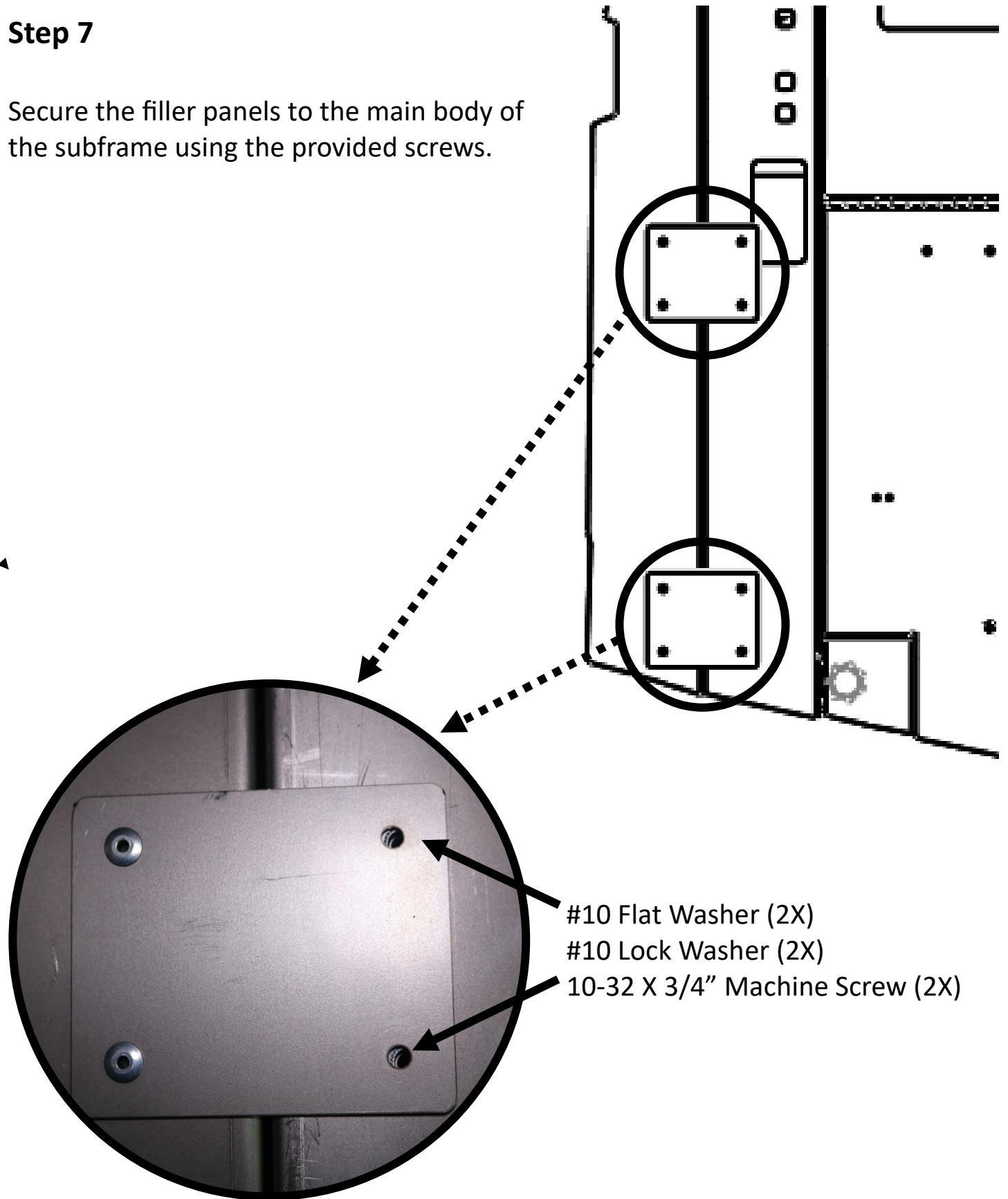

Repeat for the opposite side, not shown.

Step 8

Secure sub frame in place
factory rear cover torx
bolts.

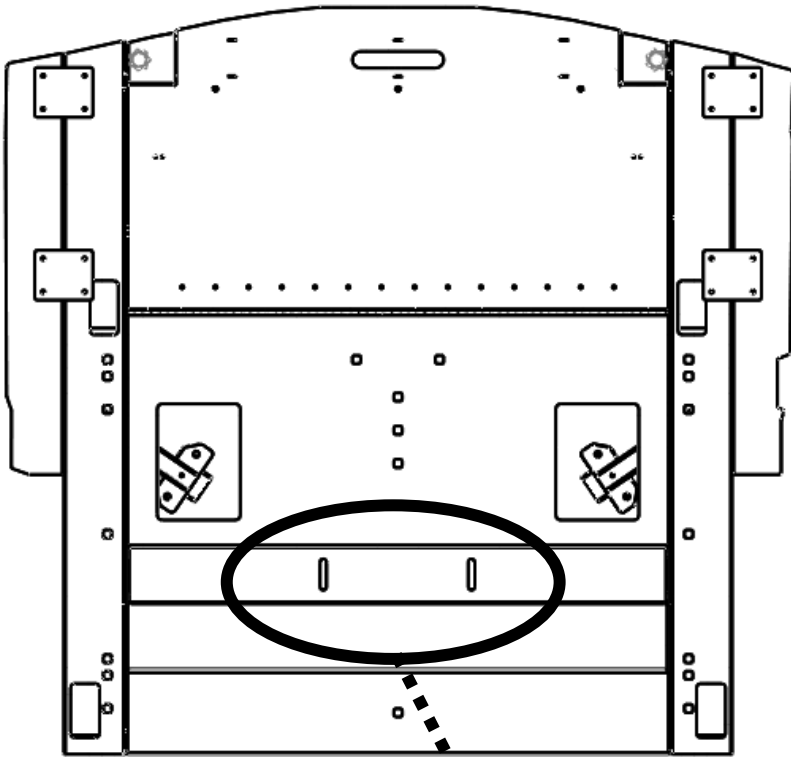

WARRANTY

D & R Electronics warrants its new products to be free from defects in material and workmanship, under normal use and service, for a period of one year on parts replacement, and one year on labor.

This warranty applies only to original purchasers acquiring the product directly from D&R Electronics, or its authorized dealers. Warranty will not be recognized without proof of purchase or bill of sale. This warranty is not transferable.

The warranty begins on the date of delivery to the first user/purchaser. This warranty shall not apply to products which must be repaired due to normal wear and tear, negligence, improper installation, abuse, misuse, or which have been

altered or modified at a facility other than D & R Electronics, or its authorized depot center. Units proved to be defective within the warranty period, based on an examination by D&R Electronics, will be replaced or repaired at D & R Electronics' option. This warranty does not cover travel expenses or labor charges for removal or installation. Lamps, flash tubes, batteries or other items considered consumables are not covered under warranty.

This warranty is in lieu of all other express warranties. D&R Electronics makes no other warranties, expressed or implied, than the express warranties contained herein.

PRODUCT RETURN POLICY

In order to provide you with faster service, product returns for repair or replacement, must have a **Return Goods Authorization Number (RGA number)**. Please contact our company to obtain a RGA number before you return the product to D & R ELECTRONICS. Write the RGA number clearly on the package. Be sure you use sufficient packing materials to avoid damage to the product being returned while in transit.

D & R ELECTRONICS assumes no responsibility or liability for expenses incurred for the removal and/or the installation of products requiring service and/or repair. Repairing or replacing product is at the discretion of D & R ELECTRONICS.

D&R ELECTRONICS Co. LTD.

CANADA
8820 George Bolton Pkwy.
Bolton, Ontario L7E 2Y4

Tel.: (905)951-9997
Fax: (905)951-0019

USA
2299 Kenmore Ave.
Building #3, Doors 11-14
Buffalo, NY, 14207

Toll Free 1-800-538-7338

www.dandrelectronics.com