

2020 Civilian Explorer Raised Sub-frame

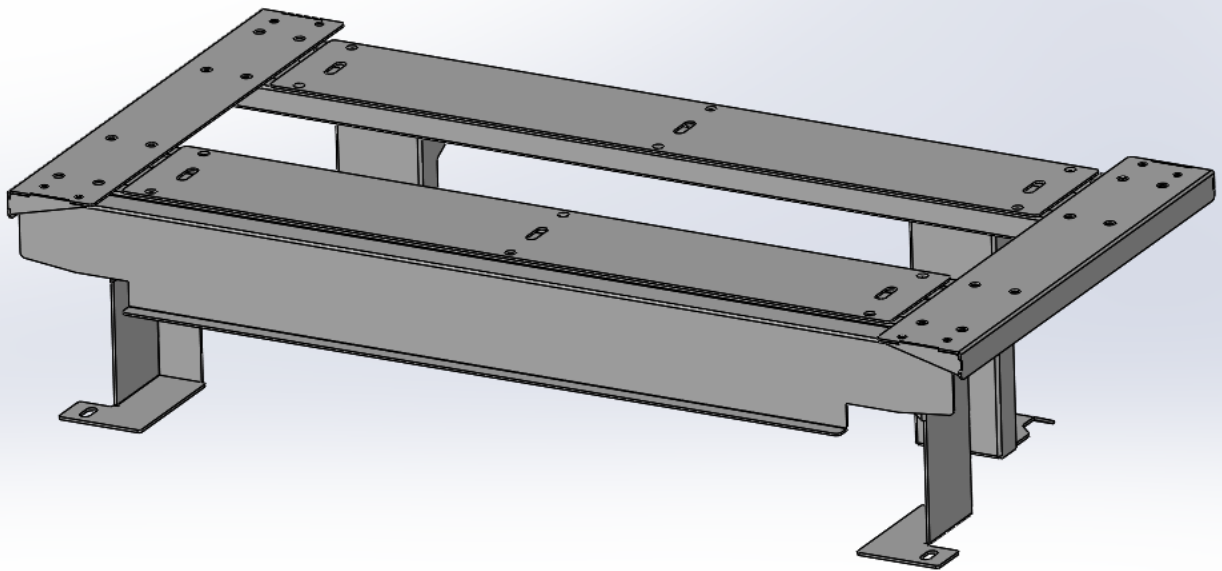

Content	Page
Hardware List	2
Assembly Overview	3-5
Installation Instructions	6-11

Hardware List

Part Number	Description	Qty
403-0005A	1/4" Flat Washer Zinc	14
403-0004	1/4"-20 Lock Washer	14
401-0074	1/4"-20 Hex Bolt (1/2") Zinc	14
401-0222	1/4" Flathead Screw (3/4") Zinc	28
401-0021	10-32 Flathead Screw (1/2") Zinc	4
407-0015A	3/8" Cage Nut	6
401-0042	3/8-16 X1"	6
403-0008	3/8" Flat Washer	6
403-0012	3/8" Lock Washer	6

Component List

Item Number	Part Number	Description	Qty
A	833-1635A	Trunk Shelf Weld	2
B	833-1637A	Front Shelf Arm DS	1
C	833-1636A	Front Shelf Arm PS	1
D	833-1639A	Rear Shelf Arm	2
E	833-1638A	Shelf Stiffener	2
F	833-1640A	Stiffener Cover	2
G	833-1641A	Front Cover	1

Front View

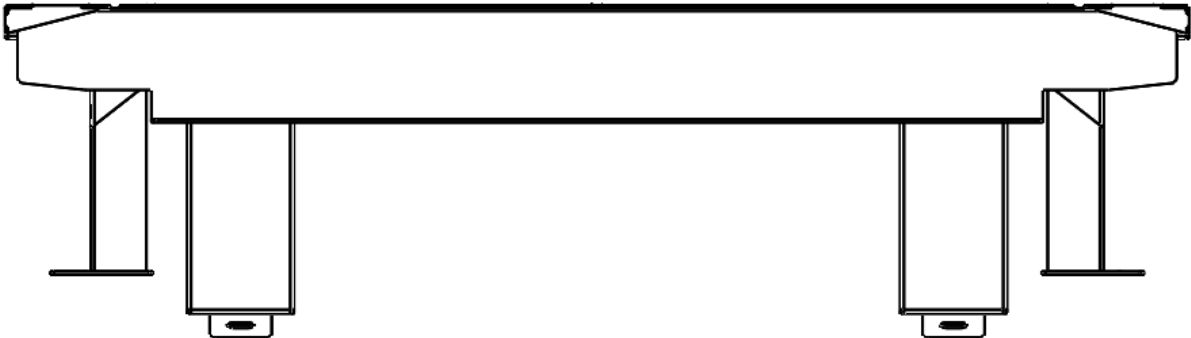

Figure 1.0

Rear View

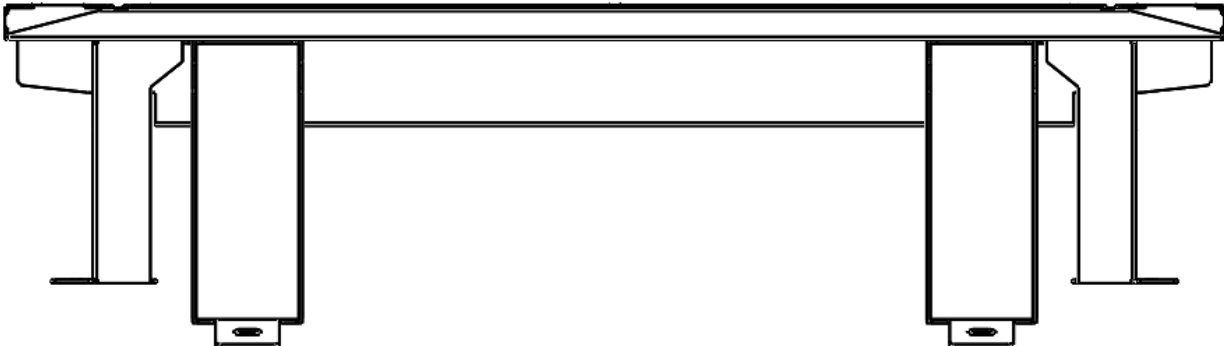

Figure 1.1

Top View

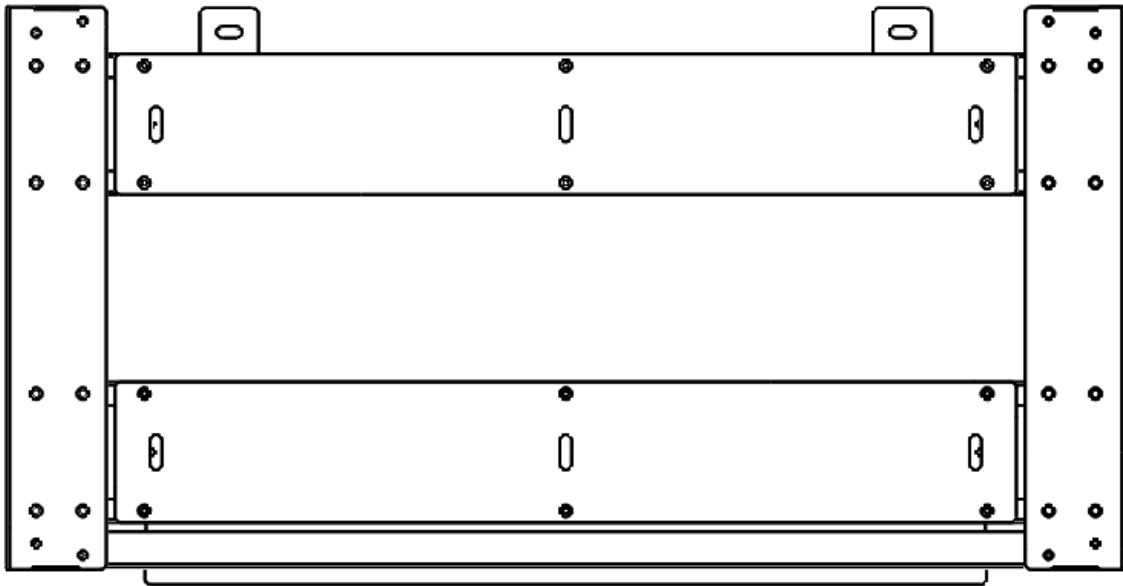

Figure 1.3

Bottom View

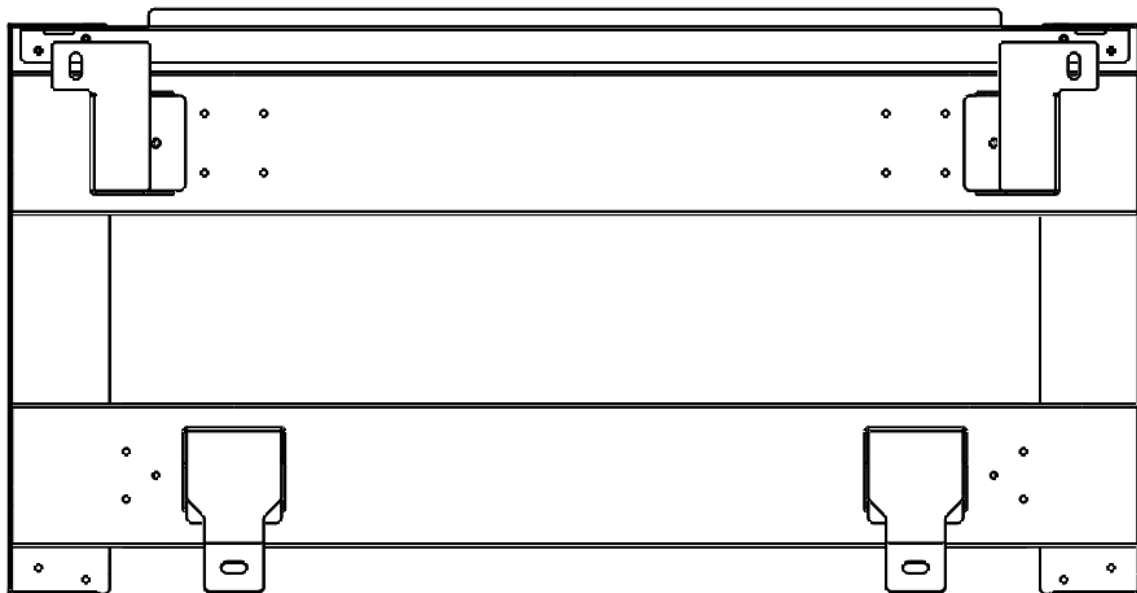

Figure 1.4

Side View

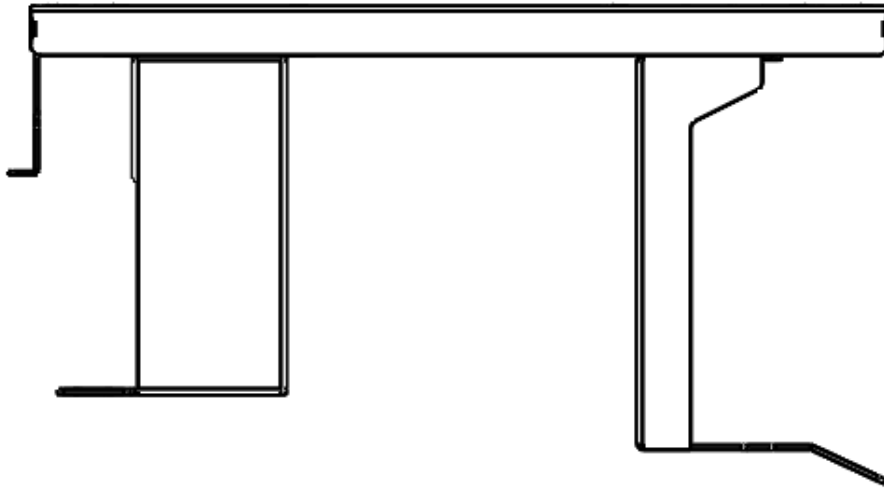

Figure 1.5

Installation Instructions:

Step 1:

Remove the rear factory flooring both top and bottom, as well as the rear row of seating. This is where the sub frame will be sitting.



Step 2:

Assemble the following parts as shown below. Use the fourteen 1/4" Hex bolts, flat and lock washers. This is easiest done by putting the mounting legs in first and then laying the supports overtop.

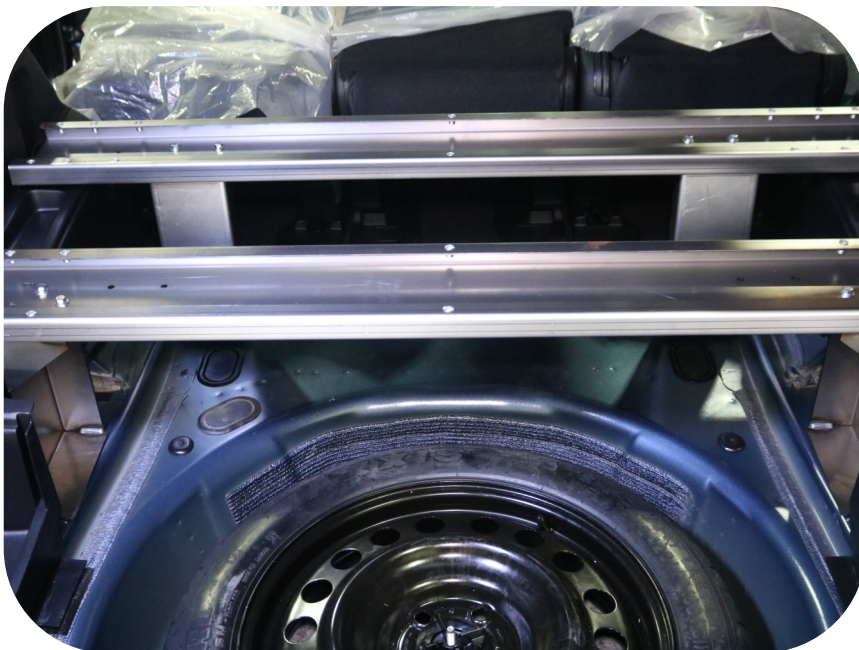
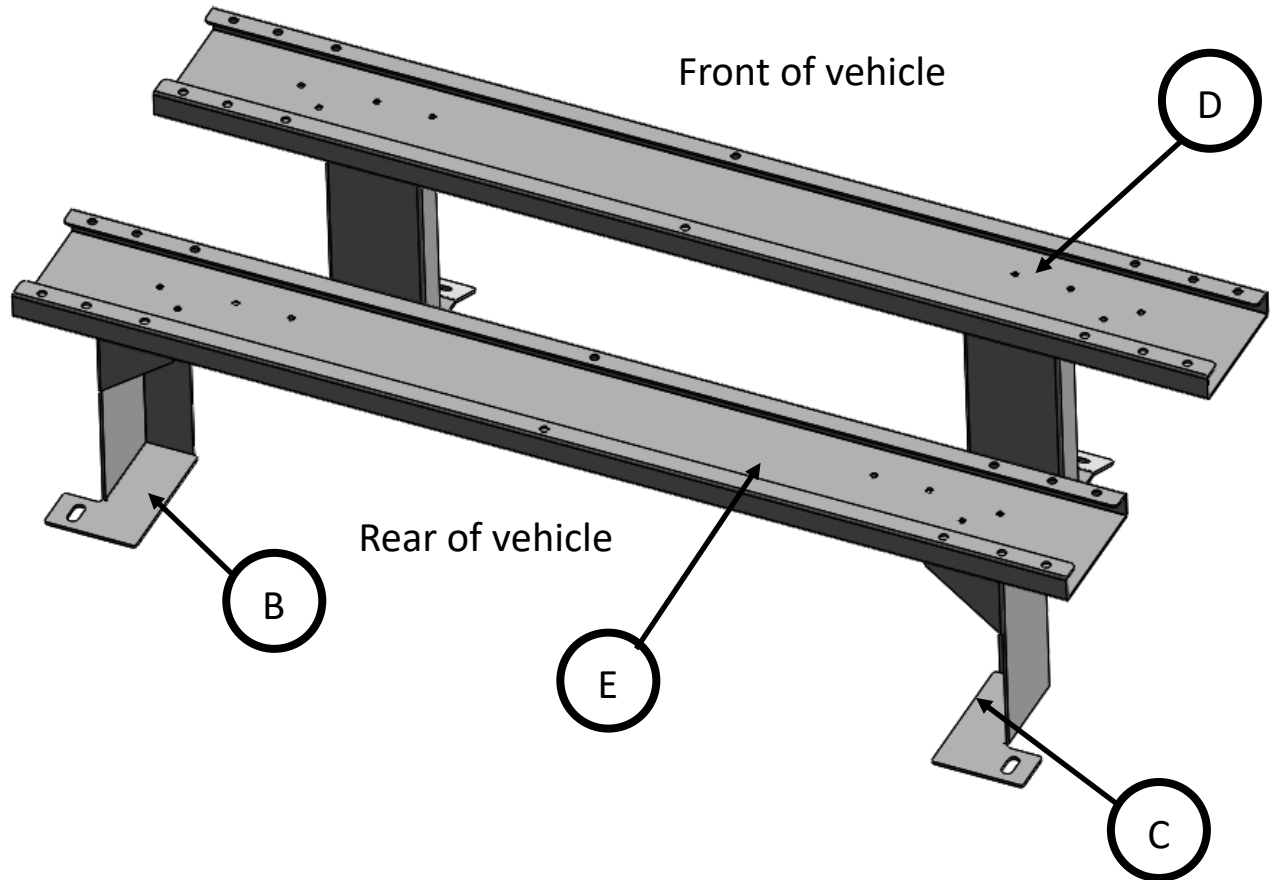

Step 3:

Install the shelf welds (A) and place the stiffener covers (F), secure in place using 1/4" flathead screw (3/4") x 28.

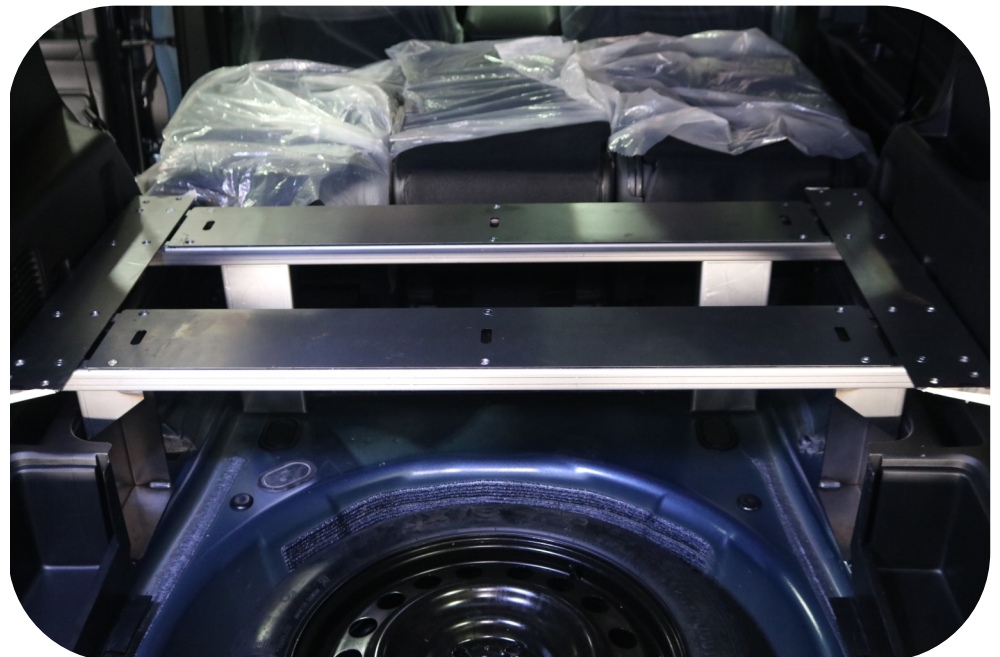
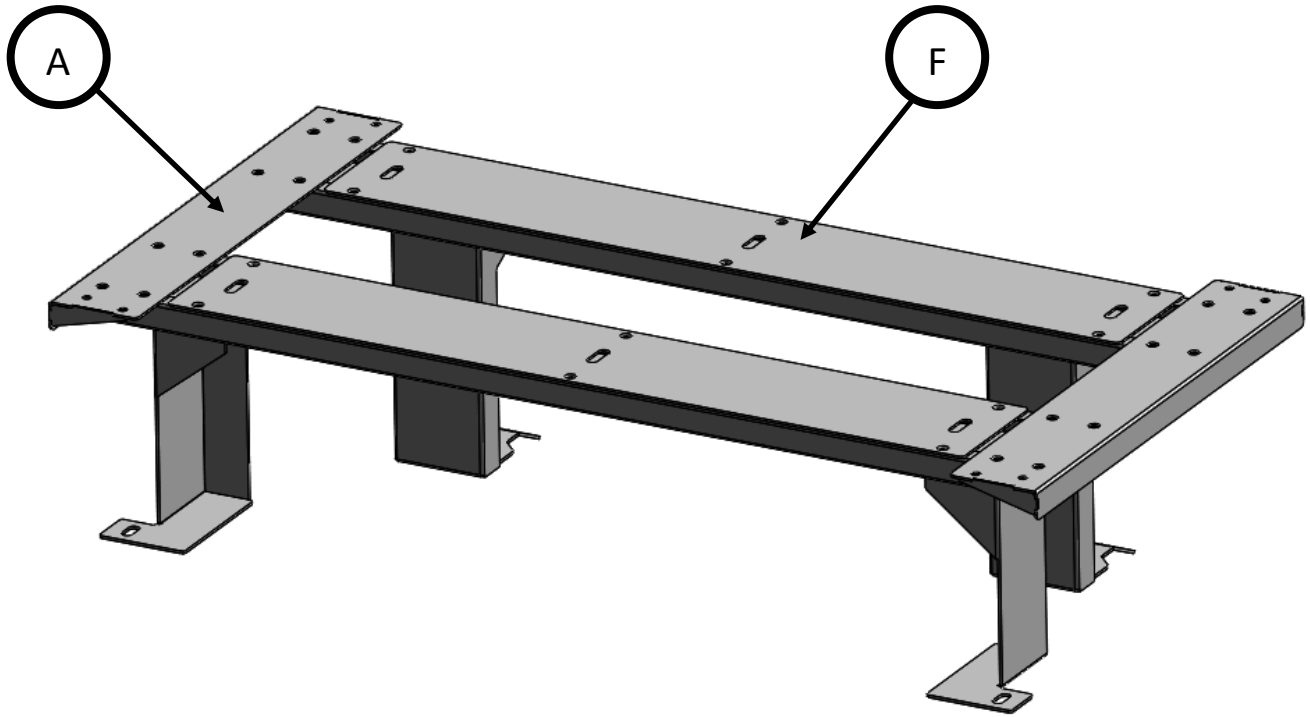

Step 4:

Attach the entire sub frame to the vehicle using the factory bolts. Both front and back need to be tight to keep the sub frame secure during transit.

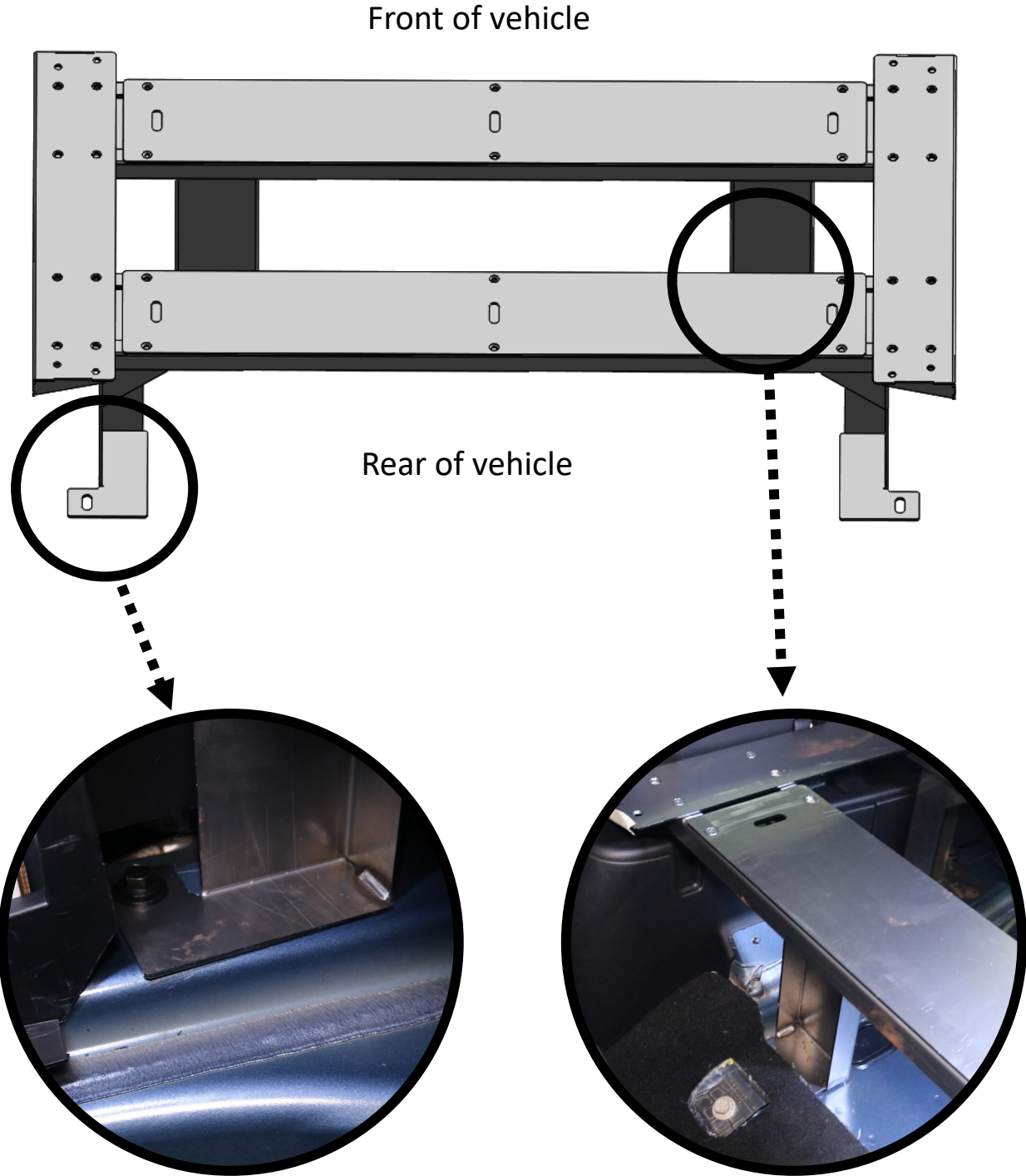

Note:

Repeat for the other side,
not shown.

Step 5:

Attach the front support using 10-32 X 1/2" Flathead machine screws. The piece is meant to be a tight fit so the plastic may have to be moved a little to get it into place. Once tightened down the entire sub frame should be mounted correctly.

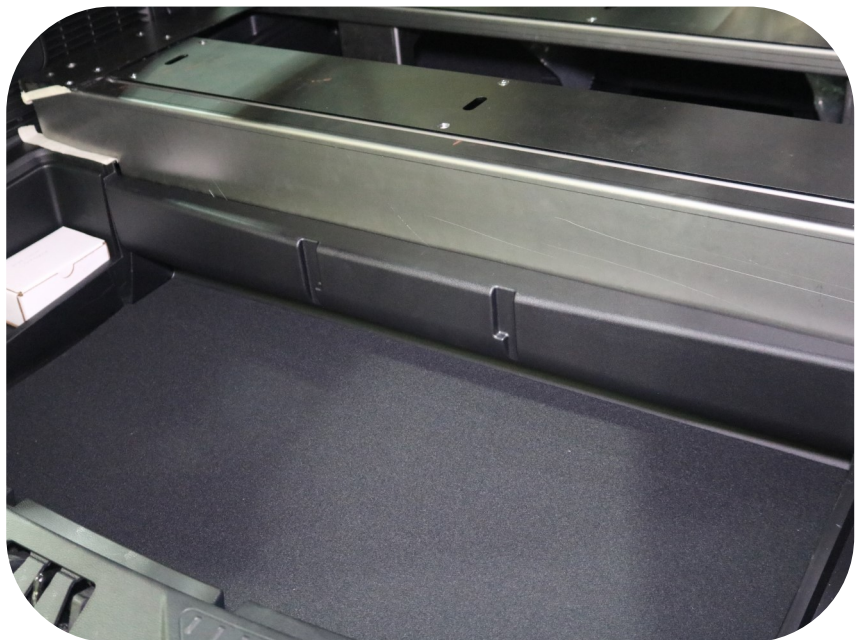
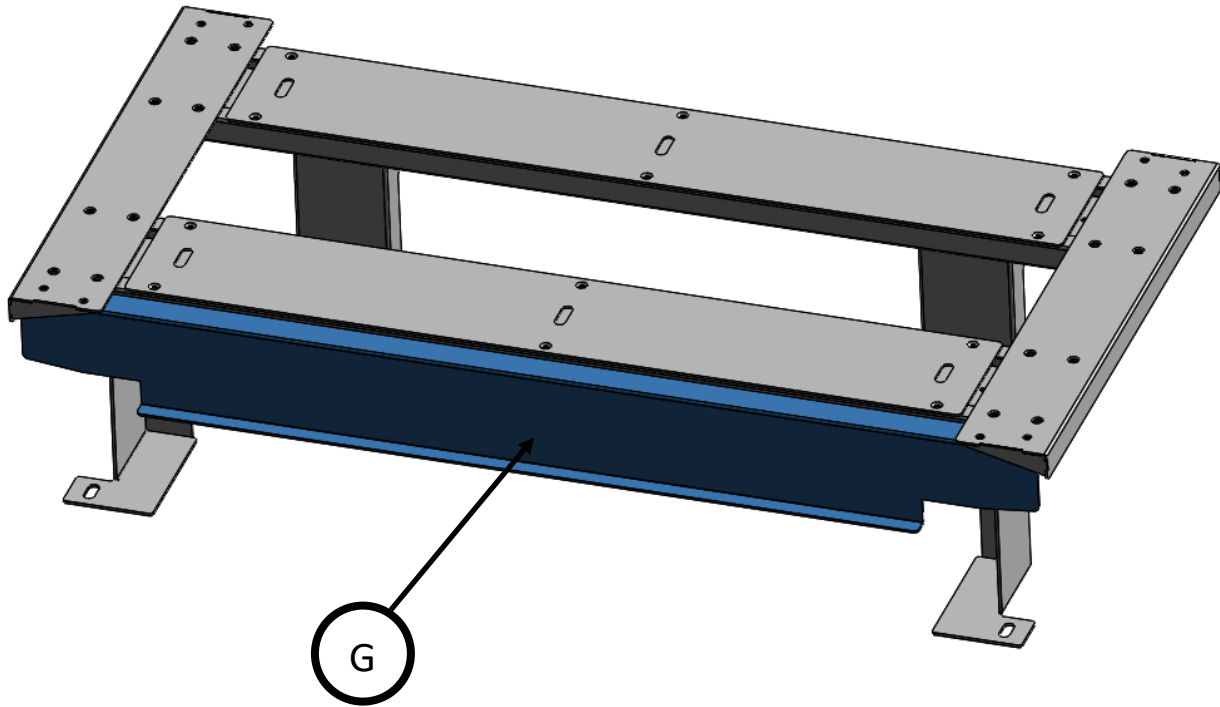

Step 6:

Slide the lower factory floor back in, the back should line up with the lip on the sub frame. Once complete, the rear factory floor can be reinstalled on top and installation is complete.



Cabinet and partition sold separately. For display only.

WARRANTY

D & R Electronics warrants its new products to be free from defects in material and workmanship, under normal use and service, for a period of one year on parts replacement, and one year on labor.

This warranty applies only to original purchasers acquiring the product directly from D&R Electronics, or its authorized dealers. Warranty will not be recognized without proof of purchase or bill of sale. This warranty is not transferable.

The warranty begins on the date of delivery to the first user/purchaser. This warranty shall not apply to products which must be repaired due to normal wear and tear, negligence, improper installation, abuse, misuse, or which have been

altered or modified at a facility other than D & R Electronics, or its authorized depot center. Units proved to be defective within the warranty period, based on an examination by D&R Electronics, will be replaced or repaired at D & R Electronics' option. This warranty does not cover travel expenses or labor charges for removal or installation. Lamps, flash tubes, batteries or other items considered consumables are not covered under warranty.

This warranty is in lieu of all other express warranties. D&R Electronics makes no other warranties, expressed or implied, than the express warranties contained herein.

PRODUCT RETURN POLICY

In order to provide you with faster service, product returns for repair or replacement, must have a **Return Goods Authorization Number (RGA number)**. Please contact our company to obtain a RGA number before you return the product to D & R ELECTRONICS. Write the RGA number clearly on the package. Be sure you use sufficient packing materials to avoid damage to the product being returned while in transit.

D & R ELECTRONICS assumes no responsibility or liability for expenses incurred for the removal and/or the installation of products requiring service and/or repair. Repairing or replacing product is at the discretion of D & R ELECTRONICS.

D&R ELECTRONICS Co. LTD.

CANADA

8820 George Bolton Pkwy.
Bolton, Ontario L7E 2Y4

Tel.: (905)951-9997
Fax: (905)951-0019

USA

2299 Kenmore Ave.
Building #3, Doors 11-14
Buffalo, NY, 14207

Toll Free 1-800-538-7338

www.dandrelectronics.com