

2021 Dodge Durango Gen I Center Console

901-0178A & 901-0179A

Installation Manual

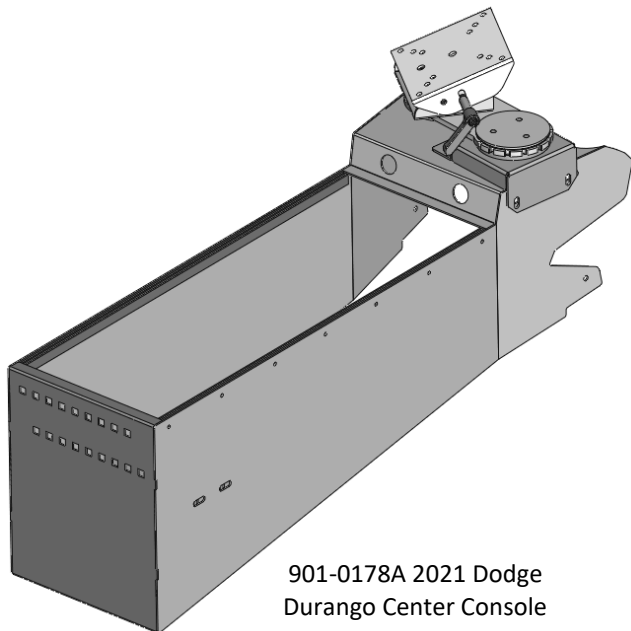

901-0178A 2021 Dodge Durango Center Console

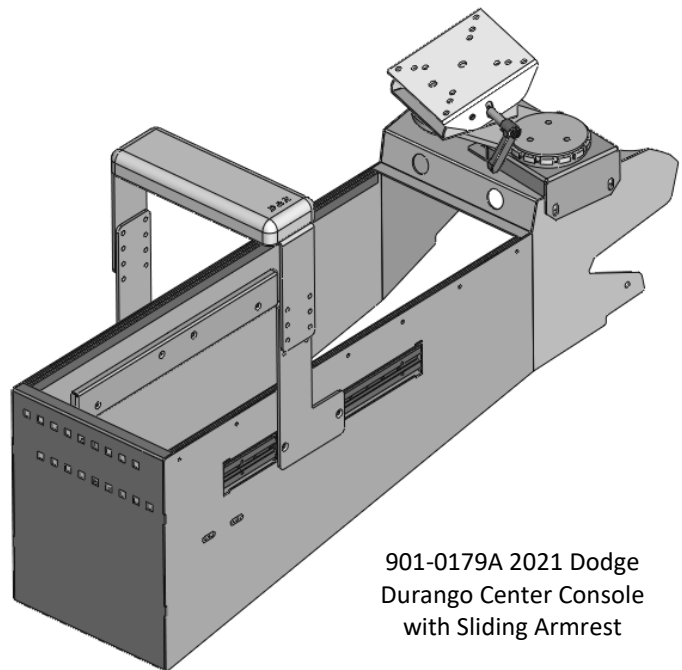

901-0179A 2021 Dodge Durango Center Console with Sliding Armrest

Content	Page
Hardware and Component List	2
Installation Instructions	3
Warranty	4

UNPACKING

Before beginning any installation, unpack the equipment received. After unpacking, examine **ALL** components received for any damage that may have occurred while in transit. If any damage has occurred, file a claim **IMMEDIATELY** with the courier stating the extent of damage. Check **ALL** envelopes, packing slips, shipping labels and tags

before removing or destroying them.

To ensure your satisfaction, open all cartons and report any shortages **within 48 hours of receipt.**

Hardware List

Part Number	Description	Quantity
401-0043	1/4-20 x 3/4" Carriage Bolt	4
403-0005A	1/4 Flat Washer	4
422-0009	1/4-20 Nyloc Nut	4

Component List

Part Number	Description	Quantity
801-0800A	Inner Bracket	1
801-0799A	Console Main Body	1
<i>OR</i>		
801-0801A	Console Main Body	1

Installation Instructions:

Part A: Vehicle Preparation

Step 1A:

Remove the factory floor plate by removing the four OEM screws that hold it in place. Hold on to the hardware for future steps.

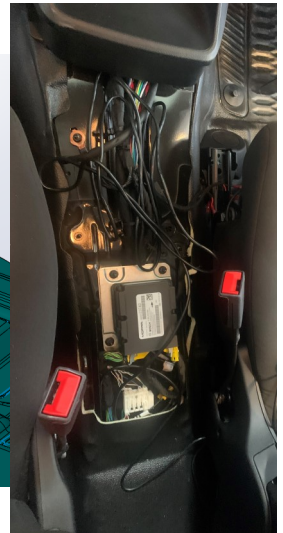
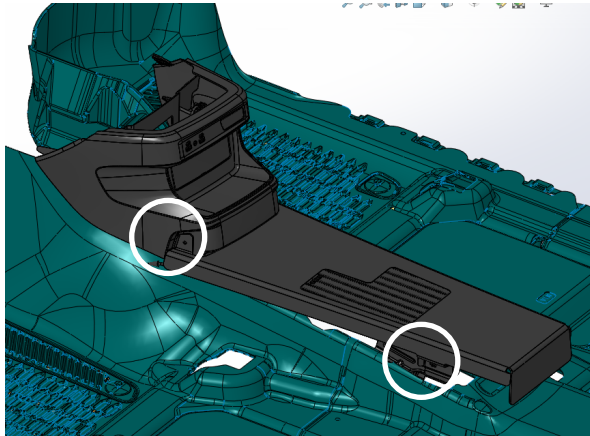

Part B: Installation of new console

Step 1B:

Position the rear mounting bracket onto the factory bracket where the factory floor plate was mounted at the rear and secure using the factory hardware removed in Step 1A.

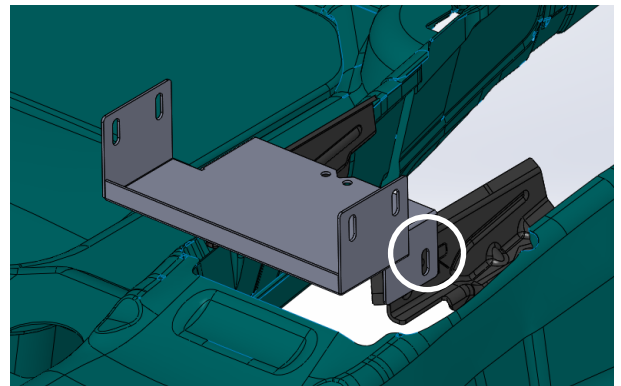

Step 2B

Carefully place the Console Main Body 801-0799A or 801-0801A depending on the version purchased into the vehicle aligning the contour of the console with the dash. Slide the console forward until the bottom holes line up with the factory ones. Secure the console using the OEM hardware removed in Step 1A.

Ensure all hardware is tight and installation is complete.



WARRANTY

D & R Electronics warrants its new products to be free from defects in material and workmanship, under normal use and service, for a period of one year on parts replacement, and one year on labor.

This warranty applies only to original purchasers acquiring the product directly from D&R Electronics, or its authorized dealers. Warranty will not be recognized without proof of purchase or bill of sale. This warranty is not transferable.

The warranty begins on the date of delivery to the first user/purchaser. This warranty shall not apply to products which must be repaired due to normal wear and tear, negligence, improper installation, abuse, misuse, or which have been

altered or modified at a facility other than D & R Electronics, or its authorized depot center. Units proved to be defective within the warranty period, based on an examination by D&R Electronics, will be replaced or repaired at D & R Electronics' option. This warranty does not cover travel expenses or labor charges for removal or installation. Lamps, flash tubes, batteries or other items considered consumables are not covered under warranty.

This warranty is in lieu of all other express warranties. D&R Electronics makes no other warranties, expressed or implied, than the express warranties contained herein.

PRODUCT RETURN POLICY

In order to provide you with faster service, product returns for repair or replacement, must have a **Return Goods Authorization Number (RGA number)**. Please contact our company to obtain a RGA number before you return the product to D & R ELECTRONICS. Write the RGA number clearly on the package. Be sure you use sufficient packing materials to avoid damage to the product being returned while in transit.

D & R ELECTRONICS assumes no responsibility or liability for expenses incurred for the removal and/or the installation of products requiring service and/or repair. Repairing or replacing product is at the discretion of D & R ELECTRONICS.

D&R ELECTRONICS Co. LTD.

CANADA

8820 George Bolton Pkwy.

Bolton, Ontario L7E 2Y4

Tel.: (905)951-9997

Fax: (905)951-0019

USA

2299 Kenmore Ave

Building #3, Doors 11-14

Buffalo, NY, 14207

Toll Free 1-800-538-7338

www.dandrelectronics.com