

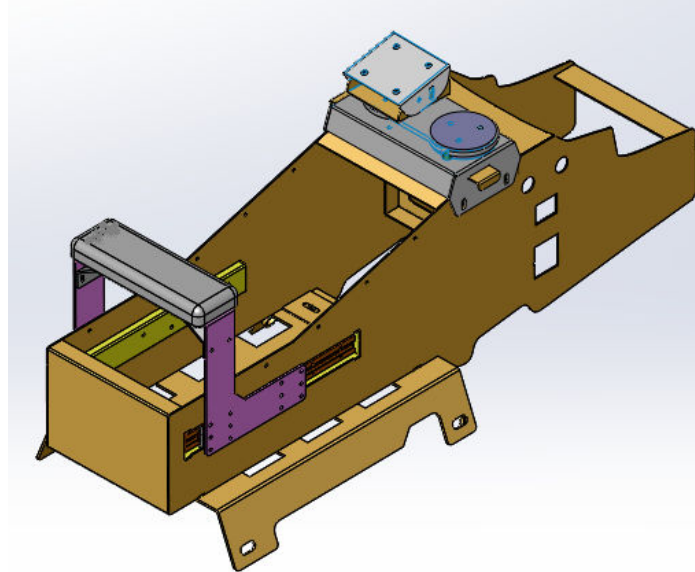

CONSOLE
CHEVROLET TAHOE 2015
901-0149A
Installation Instructions



Parts List

Part #	Description	Qty
901-0149A	2015 TAHOE CONTOUR CONSOLE	1

Hardware List

Line #	Description	Qty
1	BOLT CARRIAGE 1/4-20 X 5/8"	4
2	WASHER 1/4"	4
3	NUT NYLOCK 1/4"	4
4	# 6 TAP SCREW BLACK FOR FACEPLATES	10
5	M10 x 35mm (401-0226)	4
6	3/8" X 1 3/4" Self Tapping (401-0228)	4

NOTE: IMAGES SHOWN ARE OF 901-0129A CONSOLE. INSTALLATION OF THE 901-0149A CONSOLE TO BE DONE IN SIMILAR MANNER. SHOWN CONSOLE DOES NOT INCLUDE AN ARM REST BUT 901-0149A WILL INCLUDE AN ARM REST.

Installation Instructions

Step 1a - Remove the rubber tray and unfasten the factory screws.
Step 1b - Using a trim tool remove the dash trim shown.



Step 2

Unplug and Remove the 12V and 110V Power outlets. Caution! Do not use excessive force.

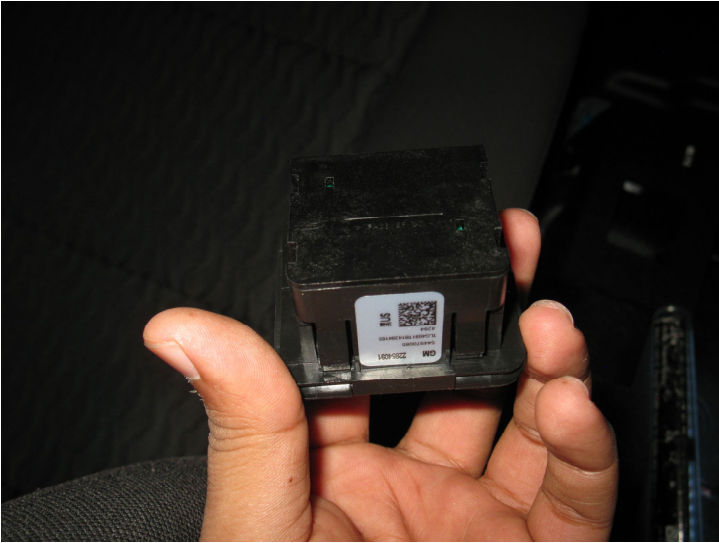

Step 3

Insert both the Power outlets on the D&R Console. Note separate the plastic casing on the 12V outlet for easy install.

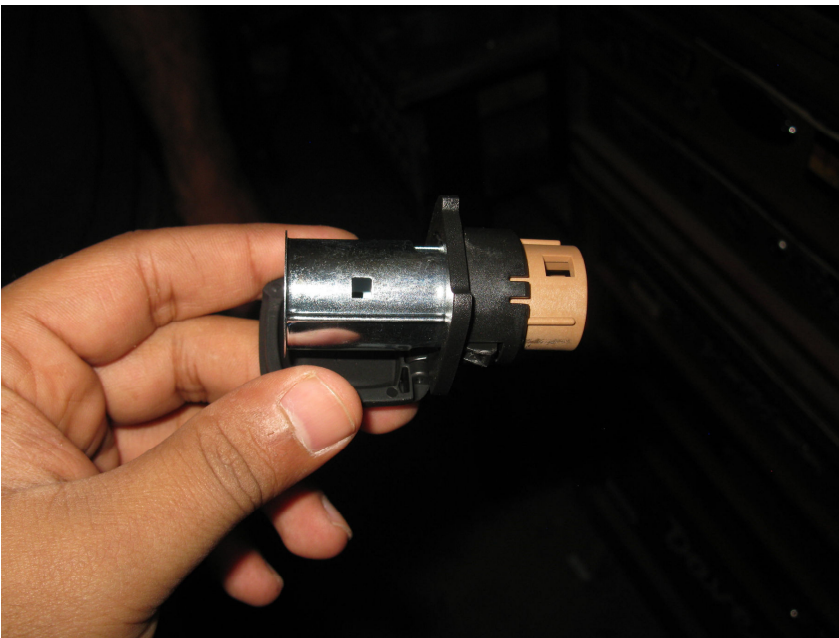

Step 4

Replace the Plastic Dash Panel and fasten the screws removed in step 1. Replace the rubber tray.

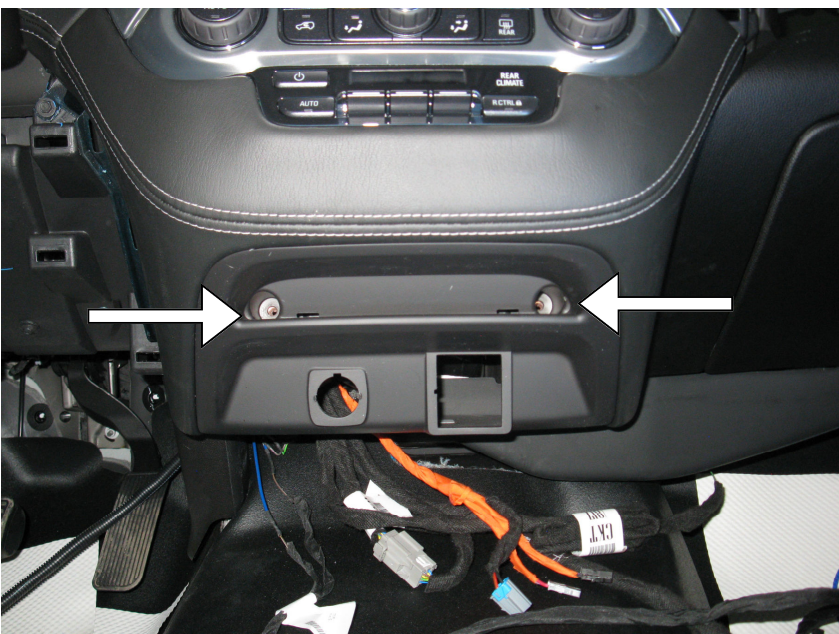

Step 5

ENSURE THAT THE FLOOR HOLES HAVE BEEN TAPPED (IF NOT, THEN USE M10 TAPPING BOLTS AND TAP THE HOLES).

Place the Floor Mount Brackets DS & PS in the Vehicle. Uses 1/4 inch spacers provided for the front. DO NOT TIGHTEN THE BOLTS UNTIL STEP 7 OR THE CONSOLE MAY NOT FIT.

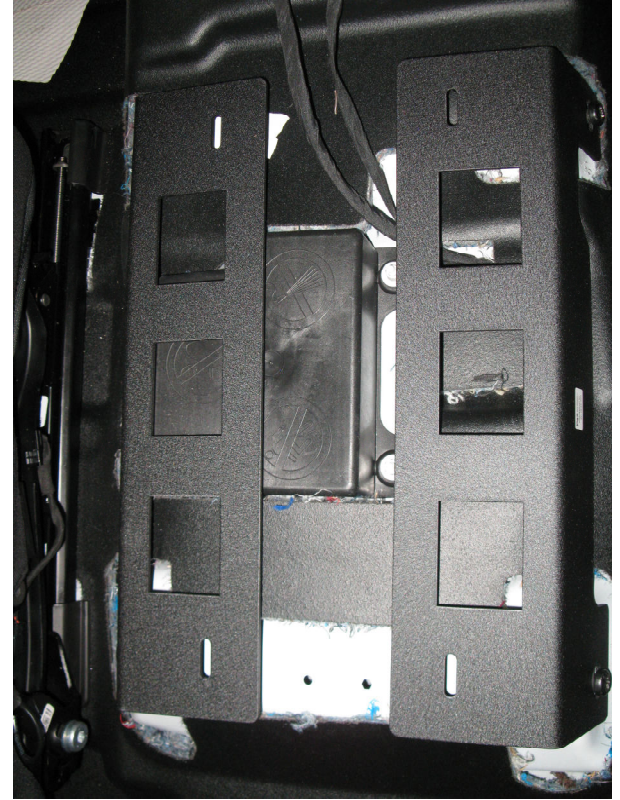

Step 6

Place the Console in position and reconnect the 12V and 110V Power outlets.

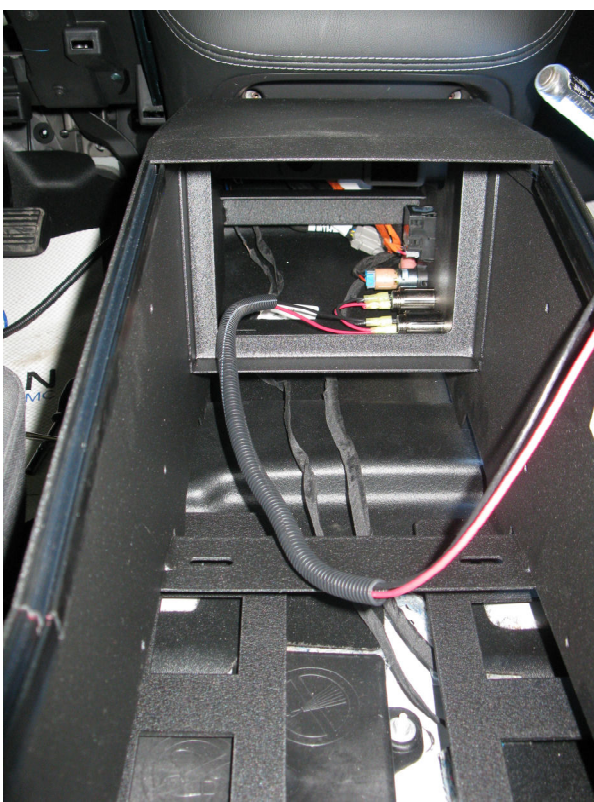

Step 7

Align the Console and Floor Mount brackets and tighten the Floor Bracket Bolts.

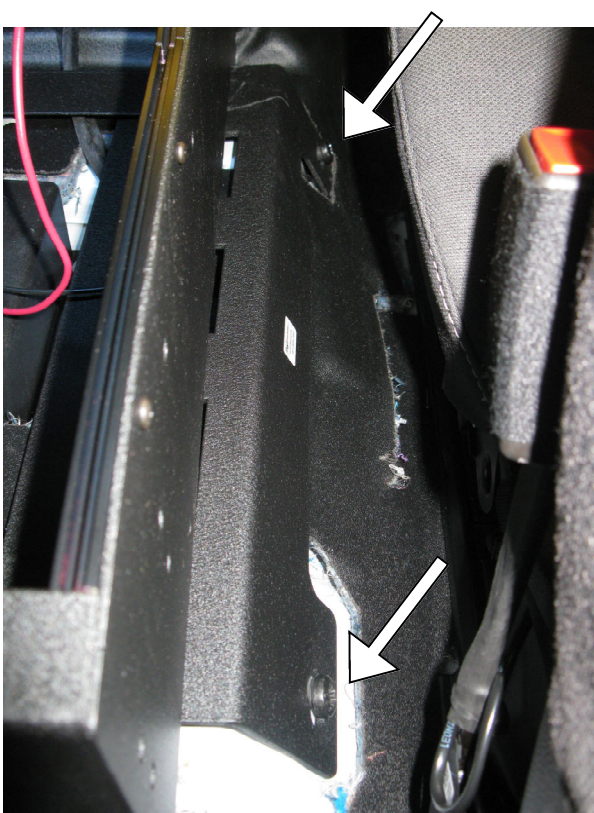

Step 8

Center the console to the floor mount brackets and secure using 4x hardware line 1,2 and 3.

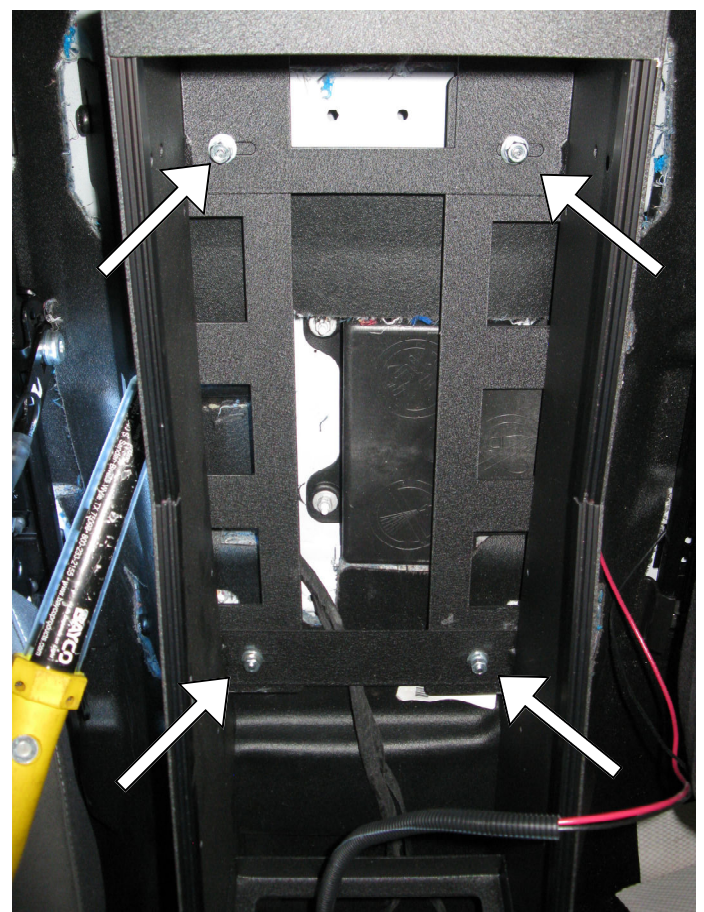

Step 9 (For Optional Side Pocket)

Place the DS or PS Console Side Pocket on the console and secure using 6x (Each) hardware line 5,6 & 7.

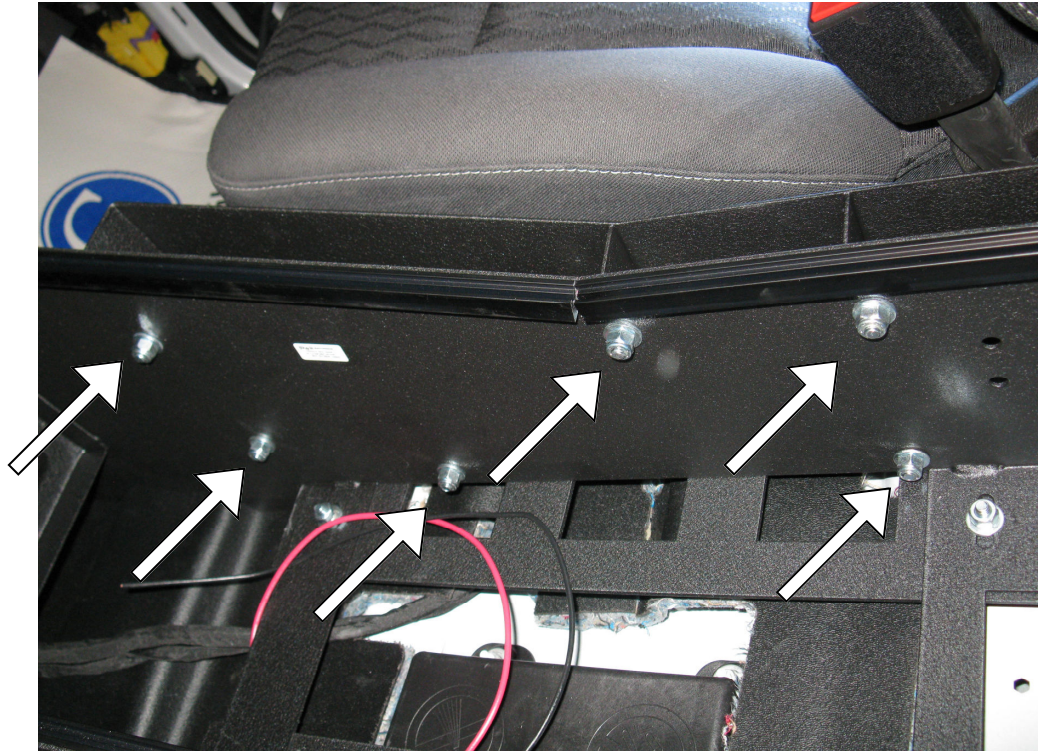
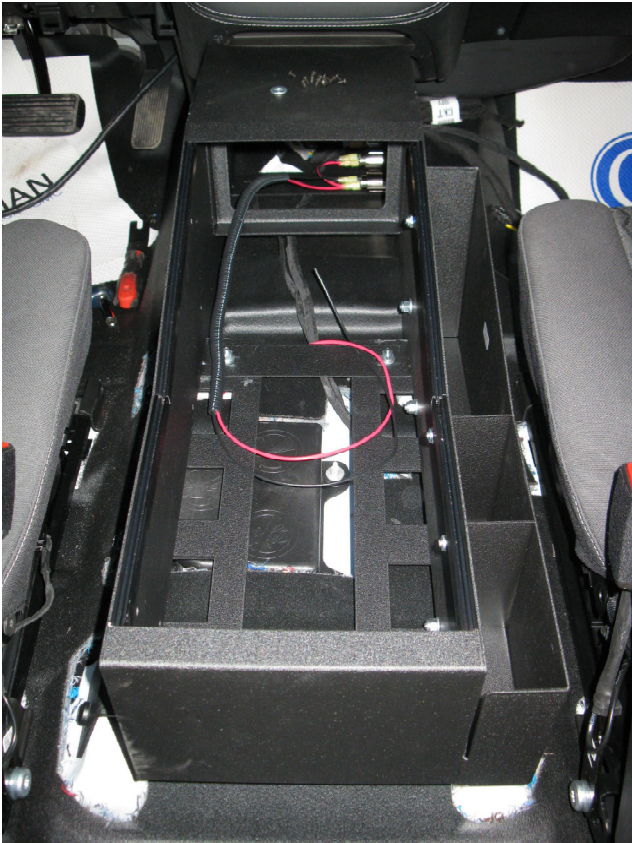

WARRANTY

D & R Electronics warrants its new products to be free from defects in material and workmanship, under normal use and service, for a period of one year on parts replacement, and one year on labor.
This warranty applies only to original purchasers acquiring the product directly from D&R Electronics, or its authorized dealers. Warranty will not be recognized without proof of purchase or bill of sale. This warranty is not transferable.
The warranty begins on the date of delivery to the first user/purchaser. This warranty shall not apply to products which must be repaired due to normal wear and tear, negligence, improper installation, abuse, misuse, or which have been altered or modified at a facility other than D & R Electronics, or its authorized depot center. Units proved to be defective within the warranty period, based on an examination by D&R Electronics, will be replaced or repaired at D & R Electronics' option. This warranty does not cover travel expenses or labor charges for removal or installation.
Lamps, flash tubes, batteries or other items considered consumables are not covered under warranty.
This warranty is in lieu of all other express warranties. D&R Electronics makes no other warranties, expressed or implied, than the express warranties contained herein.

PRODUCT RETURN POLICY

In order to provide you with faster service, product returns for repair or replacement, must have a **Return Goods Authorization Number (RGA number)**. Please contact our company to obtain a RGA number before you return the product to D & R ELECTRONICS. Write the RGA number clearly on the package. Be sure you use sufficient packing materials to avoid damage to the product being returned while in transit.
D & R ELECTRONICS assumes no responsibility or liability for expenses incurred for the removal and/or the installation of products requiring service and/or repair. Repairing or replacing product is at the discretion of D & R ELECTRONICS.

D&R ELECTRONICS Co. LTD.

CANADA
8820 George Bolton Pkwy.
Bolton, Ontario
L7E 2Y4 CANADA

USA
2299 Kenmore Ave.
Building #3, Doors 11-14
Buffalo, NY, 14207 USA

Tel.: (905)951-9997
Fax: (905)951-0019 Toll Free 1-800-538-7338
www.dandrelectronics.com