

933-0111A 2015 TAHOE SSV / PPV SUBFRAME

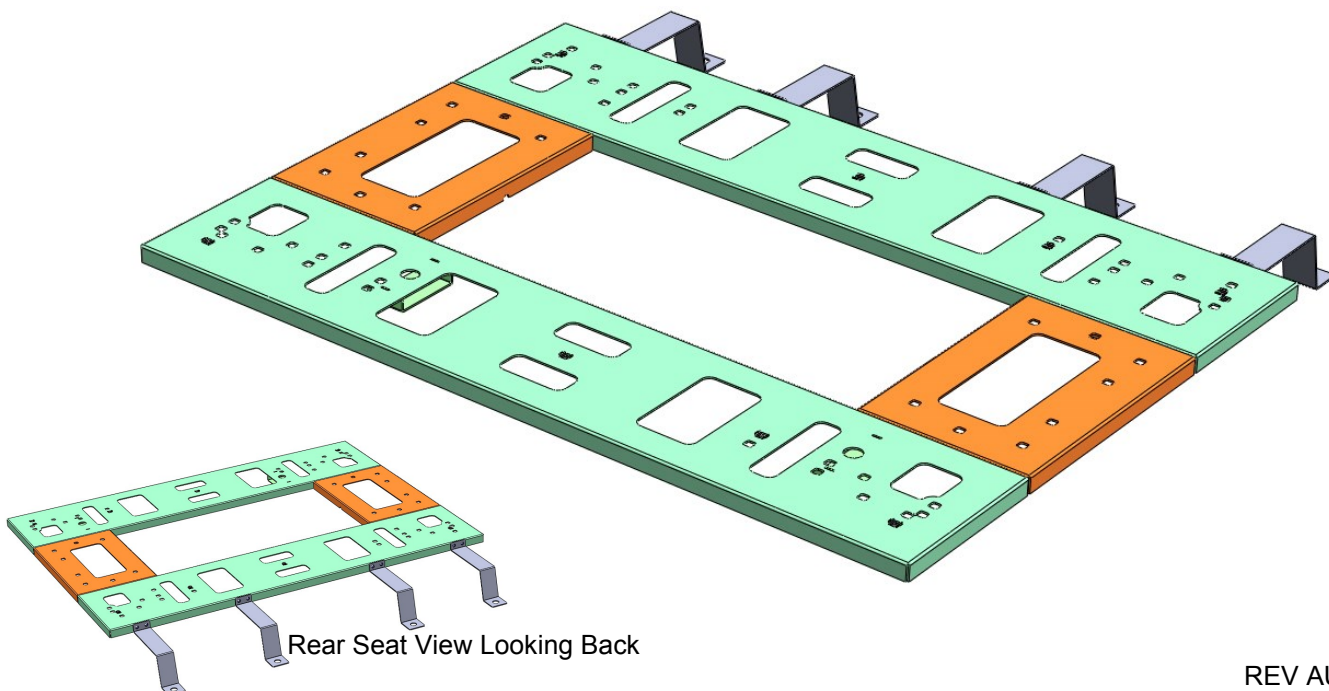

Parts List:

Item	Part Number	Part Description	Quantity
1	933-0111A	Sub-Frame for 2015+ Chevy Tahoe SSV	1
2	407-0015	NUT RETAINER,3/8-16 UNC	8
3	401-0023	BOLT,1/4-20x3/4"L,HEX,ZINC	16
4	403-0004	1/4" LOCK WASHER	16
5		1/4" FLAT WASHER	15
6	411-0106	HEX BOLT,M8X25mm Class 8.8	2
7		M8 Flat Washer	2
8		M8 Lock Washer	2
9	401-0042	BOLT, 3/8-16x1", HEX ZINC	4
10	403-0008	FLAT WASHER, 3/8" ZINC	4
11	403-0012	LOCK WASHER, 3/8" ZINC	4

Installation Instructions:

Step 1

Remove loose trunk contents, also remove the jack front the rear DS panel and place inside storage unit. Remove center seat rear nuts (4 places) keep as side for installing sub frame mounting brackets.

1

NOTE: That there is a fuse panel DS rear which will not be accessible once a cabinet is install and the cabinet will have to be removed to access any blown fuses in the location.

↑
VEHICLE
FORWARD

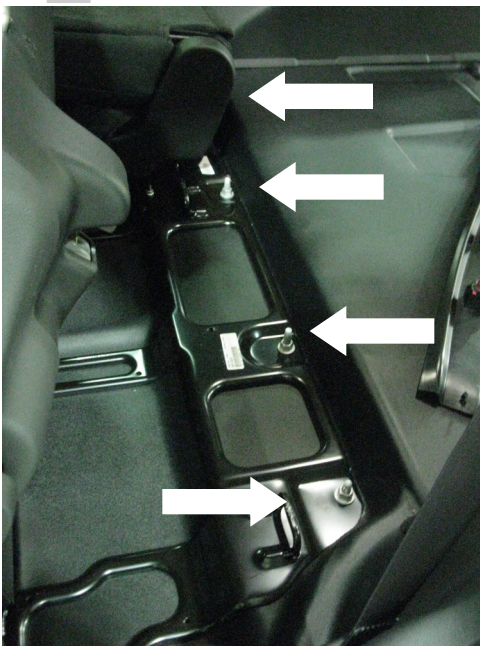

Flip up Rear Seats to access 4 nuts.

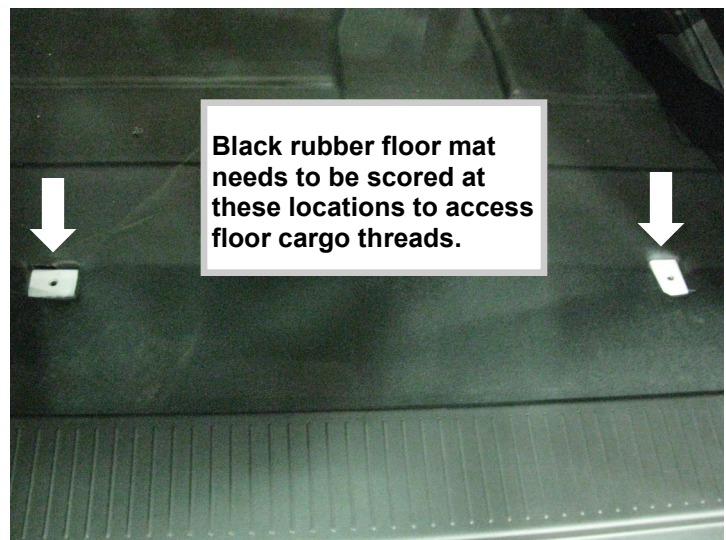

REAR CARGO FLOOR
PLAN VIEW
TAIL GATE

2

Step 2

Turn mating storage unit upside down on a protected work area.
Pre-assemble Sub frame on bottom face of overturned storage unit as shown.

Assemble all four pieces of sub frame utilizing the supplied 1/4-20 hex bolts and 1/4" lock washers.

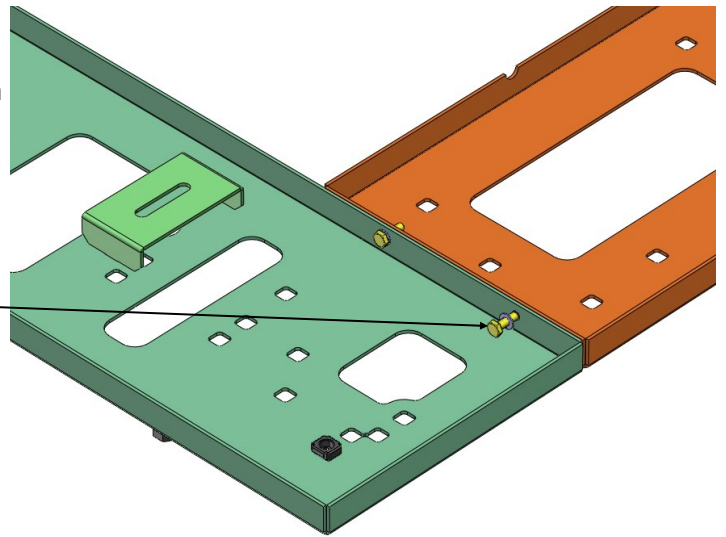

Note locations of reference notches to ensure proper assembly.

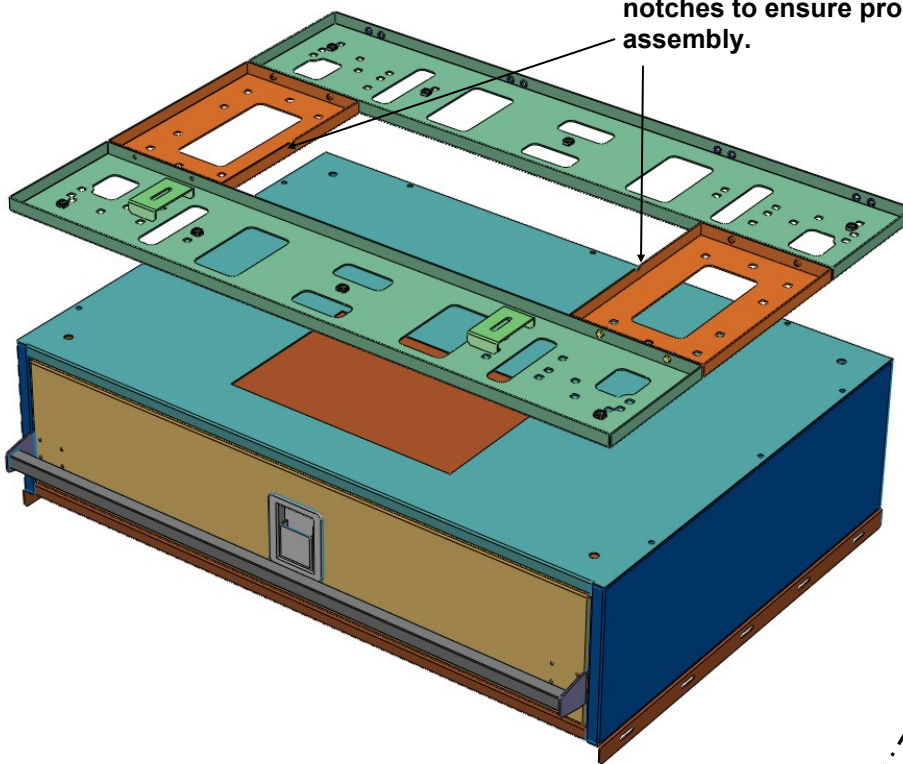

Align 3/8-16 retainer nuts with hole locations in bottom face of storage unit.

Snap retainer nuts into aligning location in sub frame.

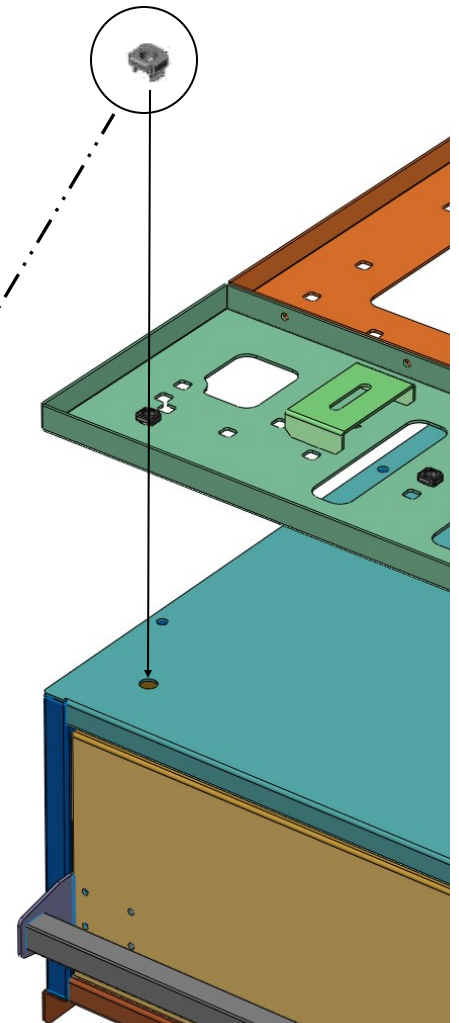
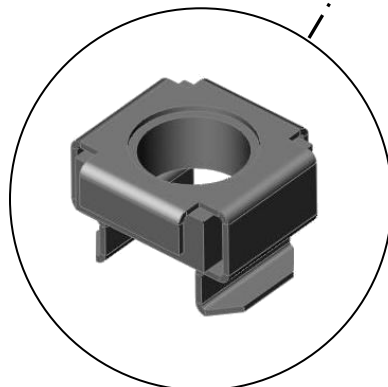

3

Step 3

Place up right sub frame into place and fasten respective bolts into place. Use supplied **M8 x 1.25 x 25mm Long/ Lock Washer / Flat Washer** to secure subframe near the tailgate to floor.

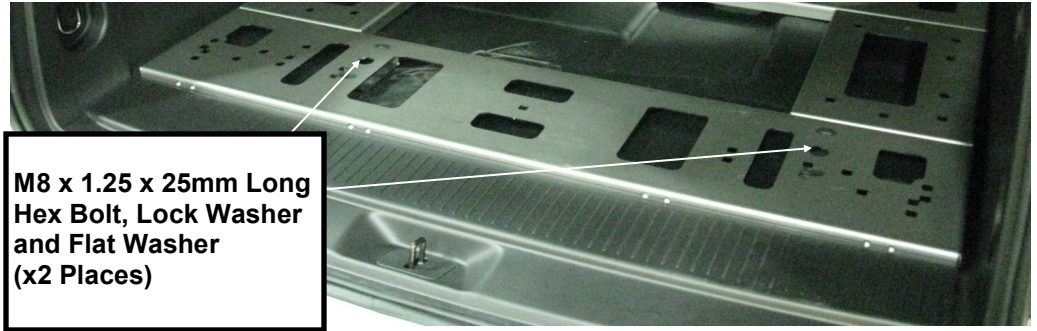

4

Step 4

Place sub frame rear brackets over factory seat studs. Secure with the four nuts removed. Using supplied 1/4-20 hex bolt/ Flat Washer/ Lock Washer (8 sets) hardware secure brackets to the back of the sub frame.

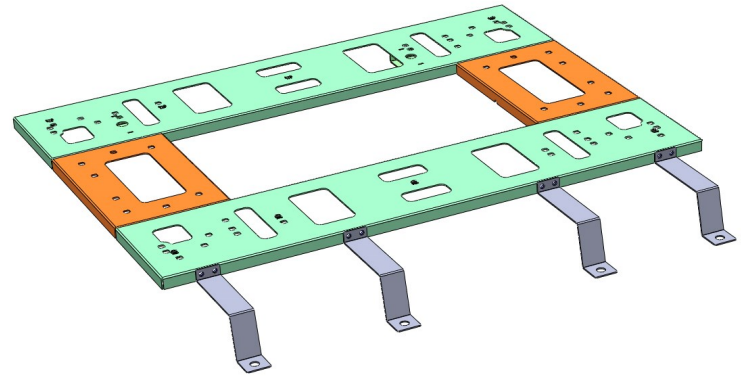

Ensure all Hardware is tightened, and Proceed to install Top Storage Unit.

WARRANTY

D & R Electronics warrants its new products to be free from defects in material and workmanship, under normal use and service for a period of one year on parts replacement and one year on labor. This warranty applies only to original purchasers acquiring the product directly from D&R Electronics, or its authorized dealers. Warranty will not be recognized without proof of purchase or bill of sale. This warranty is not transferable. The warranty begins on the date of delivery to the first user/purchaser. This warranty shall not apply to products which must be repaired due to normal wear and tear, negligence, improper installation, abuse, misuse, or which have been altered or modified at a facility other than D & R Electronics, or its authorized depot centers. Units proved to be defective within the warranty period, based on an examination by D&R Electronics, will be replaced or repaired at D & R Electronics' option. This warranty does not cover travel expenses or labor charges for removal or installation. Lamps, flash tubes, batteries or other items considered consumables are not covered under warranty. This warranty is in lieu of all other express warranties. D&R Electronics

PRODUCT RETURN POLICY

In order to provide you with faster service, product returns for repair or replacement, must have a **Return Goods Authorization Number (RGA number)**. Please contact our company to obtain a RGA number before you return the product to D & R ELECTRONICS. Write the RGA number clearly on the package. Be sure you use sufficient packing materials to avoid damage to the product being returned while in transit. D & R ELECTRONICS assumes no responsibility or liability for expenses incurred for the removal and/or the installation of products requiring service and/or repair.

Repairing or replacing product is at the discretion of D & R ELECTRONICS.

D&R Electronics Co. Ltd.

CANADA

8820 George Bolton Pkwy.
Bolton, ON L7E 2Y4

Tel: (905)951-9997
Fax: (905)951-0019

4

USA

2321 Kenmore Ave.
Buffalo, NY 14207

Toll Free 1-800-538-7338

www.dandrelectronics.com