

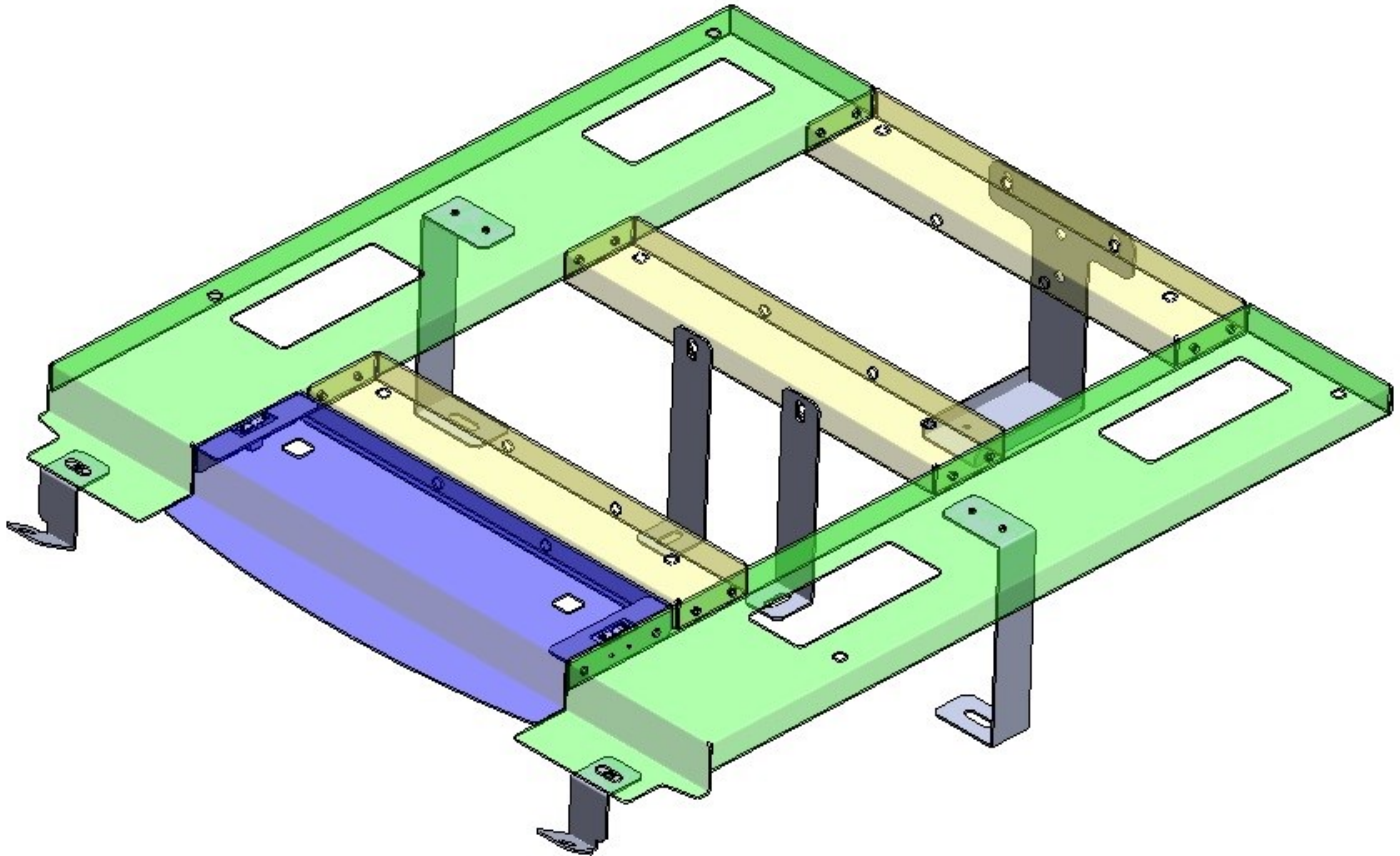

2013 Dodge Durango Sub Frame
INSTALLATION MANUAL -933-0098A



UNPACKING

Before beginning any installation, unpack the equipment received. Upon unpacking, examine **ALL** components received for any damage that may have occurred while in transit. If any damage has occurred, file a claim **IMMEDIATELY** with the courier stating the extent of damage. Check **ALL** envelopes, packing slips, shipping labels and tags before removing or destroying them. To ensure your satisfaction, open all cartons and report any shortages **within 48 hours of receipt.**

PARTS LIST

Quantity	Part Number	Description
1	933-0098A	2013 Dodge Durango Sub frame
1	833-1356A	Sub frame Front Panel
2	833-1358A	Side Bracket
1	833-1359A	Front Mount Bracket DS
1	833-1360A	Front Mount Bracket PS
2	833-1361A	Rear Mount Bracket
1	833-1381A	Rear Mid Bracket

HARDWARE LIST

Line #	Quantity	Description
1	6	BOLT HEX 3/8-16 x 1"
2	6	WASHER FLAT 3/8
3	6	WASHER LOCK 3/8
4	4	NUT NYLOCK 1/4-20
5	4	WASHER FLAT 1/4-20
6	2	SCREW SELF TAPPING #14 X 1"
7	4	M12 NUTS (for mounting bracket D and B to Truck floor)
8	4	M12 FLAT WASHER

INSTALLATION

Step 1

Vehicle Preparation

Remove the 3rd Row seating (if present). Remove all plastic panels from the area where the sub frame is to be placed.

Step 2

Frame Preparation

1. Place sub frame upside down as shown below.
2. Place the Front Mount Brackets DS & PS (Marked A) and secure using 2X Hardware Line 1,2 & 3. **Do not Tighten.**
3. Place the Rear Mount Brackets (Marked B) and secure using 2X Hardware Line 1, 2 & 3. **Do not Tighten.**
4. Place the Rear Mid Bracket (Marked C) and secure using 2X Hardware Line 1, 2 & 3. **Do not Tighten.**
5. Place the Side Brackets (Marked D) and secure using 4X Hardware Line 4 & 5.

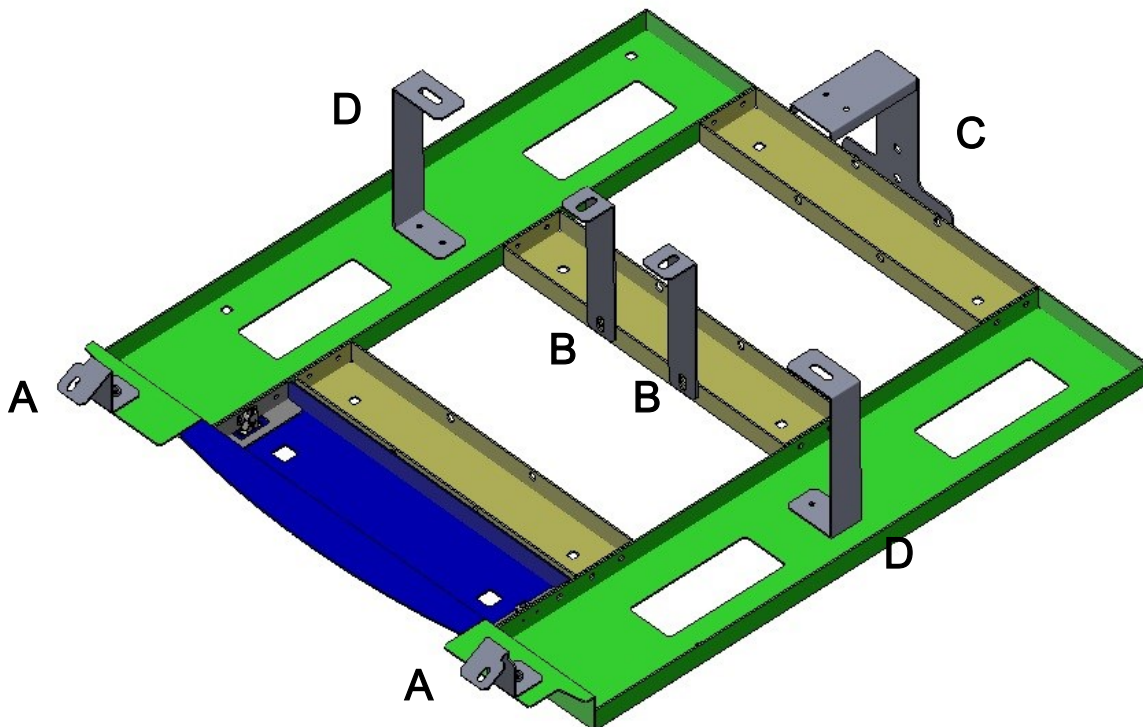

Step 3 Frame into Vehicle

1. Open the lift gate and carefully place the sub frame over the 3rd row seat Bolts and secure sub frame using Hardware Line# 7.

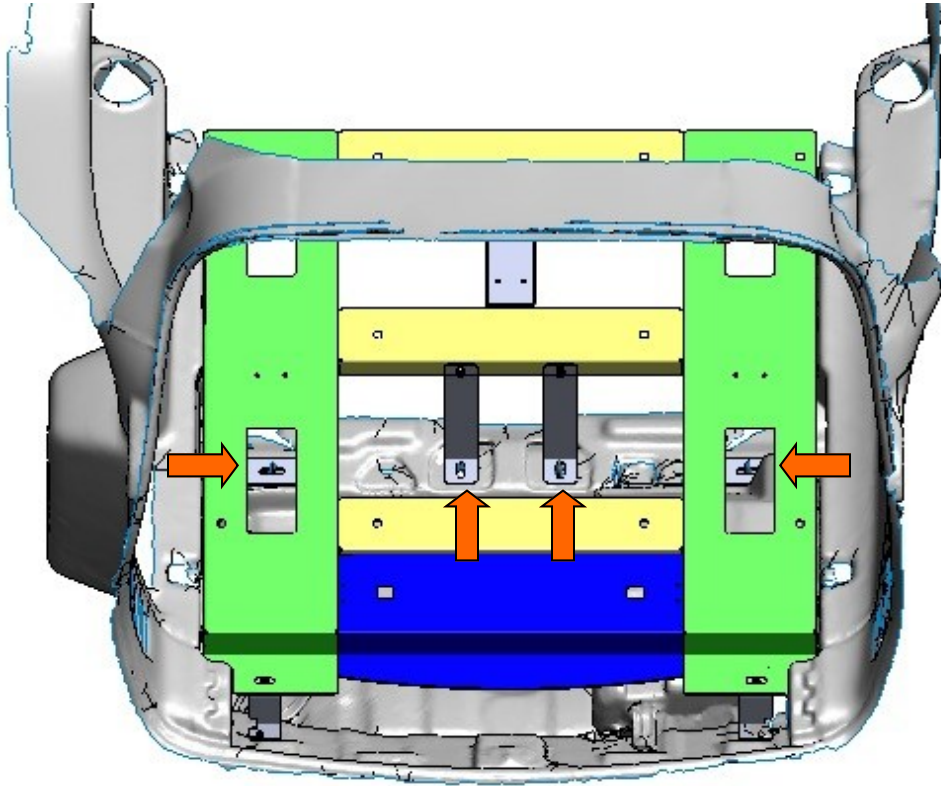

An overall view of the sub frame, looking in from the rear of the vehicle.

2. Secure Sub frame front mount brackets to vehicle using factory nut and stud present on vehicle.

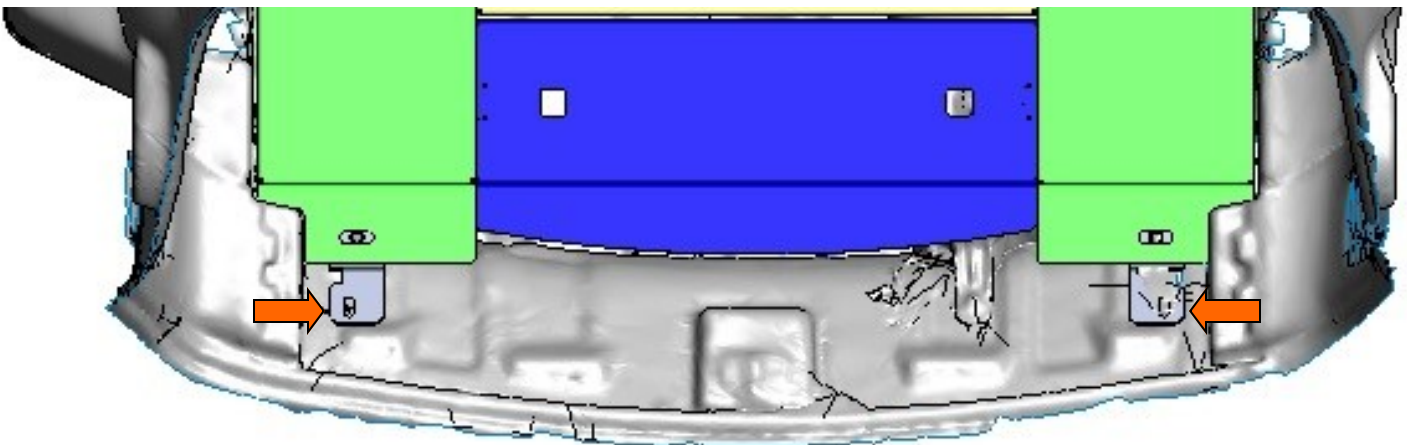

3. Tighten all Nuts and Bolts that were left loose until now.

4. Using Hardware Line 6, Secure the Rear End of the Sub frame.

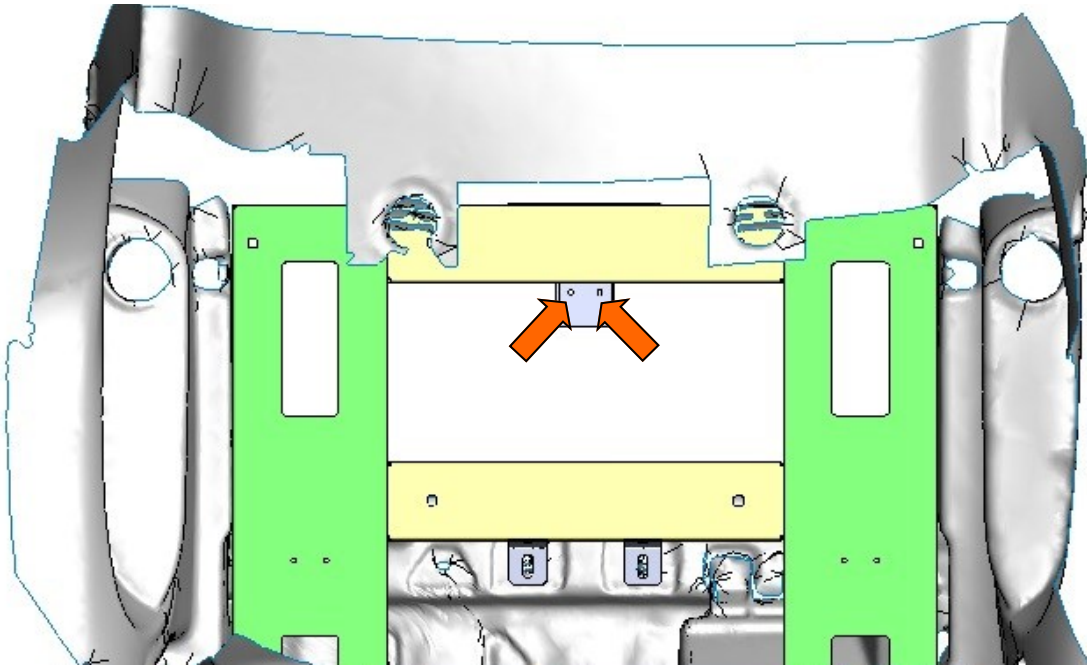

WARRANTY

D & R Electronics warrants its new products to be free from defects in material and workmanship, under normal use and service for a period of one year on parts replacement and one year on labor. This warranty applies only to original purchasers acquiring the product directly from D&R Electronics, or its authorized dealers. Warranty will not be recognized without proof of purchase or bill of sale. This warranty is not transferable. The warranty begins on the date of delivery to the first user/purchaser. This warranty shall not apply to products which must be repaired due to normal wear and tear, negligence, improper installation, abuse, misuse, or which have been altered or modified at a facility other than D & R Electronics, or its authorized depot centers. Units proved to be defective within the warranty period, based on an examination by D&R Electronics, will be replaced or repaired at D & R Electronics' option. This warranty does not cover travel expenses or labor charges for removal or installation. Lamps, flash tubes, batteries or other items considered consumables are not covered under warranty. This warranty is in lieu of all other express warranties. D&R Electronics makes no warranties, expressed or implied, other than the express warranties contained herein.

PRODUCT RETURN POLICY

In order to provide you with faster service, product returns for repair or replacement, must have a **Return Goods Authorization Number (RGA number)**. Please contact our company to obtain a RGA number before you return the product to D & R ELECTRONICS. Write the RGA number clearly on the package. Be sure you use sufficient packing materials to avoid damage to the product being returned while in transit.

D & R ELECTRONICS assumes no responsibility or liability for expenses incurred for the removal and/or the installation of products requiring service and/or repair.

D&R ELECTRONICS Co. LTD.
CANADA
8820 George Bolton Pkwy.
Bolton, Ontario L7E 2Y4
Tel.: (905)951-9997 Fax: (905)951-0019
Toll Free 1-800-538-7338
www.dandrelectronics.com

USA
2321 Kenmore Ave.
Buffalo, NY 14207